

TOSHIBA

Leading Innovation >>>

SV6**D Digital
Series



REGZA



Contents

INSTALLING YOUR TV

Safety Precautions	4
Installation and important information	5
The remote control	6
Inserting batteries and effective range of the remote	7

CONNECTING YOUR TV

Connecting external equipment	8
Connecting an HDMI™ or DVI device to the HDMI input	9
To connect an HDMI device	9
To connect a DVI device	9
REGZA-LINK connection	10
Connecting a computer	11
To connect a PC to the RGB/PC terminal	11
To connect a PC to the HDMI terminal	11
Connecting a home network	12
To connect the TV to a home network	12
Controls and input connections	13
Switching on	13
Using the remote control	13
Using the controls and connections	13

SETTING UP YOUR TV

Startup Application	14
Quick Setup	14
Ant/Cable In (if available)	15
Auto Tuning	16
ATV Manual Tuning	16
Tuning	16
Skip	18
Sorting positions	18
DTV Manual Tuning	19
Manual Tuning	19
Manual Tuning for DVB-C	19
DTV Settings	19
Channels	19
Auto Channel Update	20
DVB Character Set	20
Dynamic Scan	20
Location setting	20
Analogue switch-off	20

CONTROLS AND FEATURES

General controls	21
Quick Menu	21
Selecting positions	21
The Time Display – analogue only	21
Stereo and Bilingual transmissions	21
Sound controls	22
Volume controls and mute sound	22
Dual	22
Bass, Treble and Balance	22
Advanced Sound Settings	23
Dolby Volume®	23
Dynamic Range Control	23
Audio Level Offset	23
Headphone Settings	23
Audio Description	24
Widescreen viewing	25
Picture controls	27
Picture Position	27
Picture Mode	27
Picture preferences	27
Reset	28
3D Colour Management	28
Base Colour Adjustment	28
Colour Temperature	28
Auto Brightness Sensor Settings	29
LED Backlight Control	29
Black/White Level	29
Static Gamma	29
MPEG NR – Noise Reduction	29
DNR – Digital Noise Reduction	29
Resolution+	30
Active Vision M200	30
Film Stabilization	30
Expert Mode	30
Resetting the advanced picture settings	30
Control Visualization	31
Automatic Format (Widescreen)	31
4:3 Stretch	31
Blue Screen	31
Side panel adjustment	31
Picture still	31
HDMI Information Display	31
Using the Media Player	32
To select the Auto Start function	32
To open the Media Player	32
Viewing photo files	33
Viewing movie files	34
Playing music files	35
Using a networked server PC	36
To open the Media Player	36

Using the Photo Frame feature	38	Using REGZA-LINK	51
To open Photo Frame	38	Enable REGZA-LINK	51
Setting the features	38	TV Auto Power On	51
Other features	40	Auto Standby	51
Panel Lock	40	Amplifier Control	51
TOSHIBA Illumination	40	Speaker Preference	51
The timers	40	REGZA-LINK input source selection	51
Programme Timers – digital only	40	REGZA-LINK playback device control	52
On Timer	41	REGZA-LINK one touch play	52
Sleep Timer	41	REGZA-LINK system standby	52
Digital on-screen information and Programme		REGZA-LINK system audio control	52
Guide	42	REGZA-LINK PC link	52
Information	42	Setting up the network address for the LAN port	53
Guide	43	Auto Setup	53
Genre selection/searching	43	Manual Setup	53
Digital settings – parental control	44	TEXT SERVICES	
Setting the PIN	44	Text services	54
Parental Setup	44	Selecting modes	54
Digital settings – Channel Options	45	Text information	54
Channel List	45	Navigating pages using Auto	54
Skipping channels	45	Navigating pages using LIST	54
Locking channels	45	Control buttons	55
Digital settings – other settings	46	PROBLEM SOLVING	
Subtitles	46	Questions and Answers	56
Audio languages	46	INFORMATION	
Common Interface	46	License Information	59
Software Upgrade and Licenses	47	Information	60
Auto Upgrade	47	Specifications and accessories	62
Searching for New Software	47		
Software Licenses	47		
System Information and Reset TV	47		
System Information	47		
Automatic Power Down	47		
Reset TV	47		
PC Settings	48		
Horizontal and Vertical Position	48		
Clock Phase	48		
Sampling Clock	48		
Reset	48		
Input selection and AV connections	49		
Input selection	49		
External input skip	49		
Input signal selection	49		
Woofer setting	49		
PC Audio	50		
HDMI 1 Audio	50		
HDMI Settings	50		
Digital Audio Output	50		

Safety Precautions

This equipment has been designed and manufactured to meet international safety standards, but like any electrical equipment, care must be taken to obtain the best results and for safety to be assured. Please read the points below for your own safety. They are of a general nature and are intended to help with all electronic consumer products. Some points may not apply to the goods you have just purchased.

Air Circulation

Leave more than 10cm clearance around the television to allow adequate ventilation. This will prevent overheating and possible damage to the television. Dusty places should also be avoided.

Heat Damage

Damage may occur if the television is left in direct sunlight or near a heater. Avoid places subject to extremely high temperatures or humidity. Place in a location where the temperature remains between 5°C (41°F) min. and 35°C (94°F) max.

Mains Supply

The mains supply required for this equipment is 220-240v AC 50/60Hz. Never connect to a DC supply or any other power source. DO ensure that the television is not standing on the mains lead. Use only the supplied lead.

DO NOT cut off the mains plug from this equipment. The plug incorporates a special Radio Interference Filter, the removal of which will impair its performance.

IF IN DOUBT, PLEASE CONSULT A COMPETENT ELECTRICIAN.

Do

DO read the operating instructions before you attempt to use the equipment.

DO ensure that all electrical connections (including the mains plug, extension leads and inter-connections between pieces of equipment) are properly made and in accordance with the manufacturers' instructions. Switch off and withdraw the mains plug before making or changing connections.

DO consult your dealer if you are ever in doubt about the installation, operation or safety of your equipment.

DO be careful with glass panels or doors on equipment.

DO NOT REMOVE ANY FIXED COVERS AS THIS WILL EXPOSE DANGEROUS AND 'LIVE' PARTS.

THE MAINS PLUG IS USED AS A DISCONNECTING DEVICE AND THEREFORE SHOULD BE READILY OPERABLE.

Do not

DO NOT obstruct the ventilation openings of the equipment with items such as newspapers, tablecloths, curtains, etc. Overheating will cause damage and shorten the life of the equipment.

DO NOT allow electrical equipment to be exposed to dripping or splashing or objects filled with liquids, such as vases, to be placed on the equipment.

DO NOT place hot objects or naked flame sources, such as lighted candles or nightlights, on or close to equipment. High temperatures can melt plastic and lead to fires.

DO NOT use makeshift stands and NEVER fix legs with wood screws. To ensure complete safety, always fit the manufacturers' approved stand, bracket or legs with the fixings provided according to the instructions.

DO NOT leave equipment switched on when it is unattended, unless it is specifically stated that it is designed for unattended operation or has a standby mode. Switch off by withdrawing the plug, and make sure your family knows how to do this. Special arrangements may need to be made for people with disabilities.

DO NOT continue to operate the equipment if you are in any doubt about it working normally, or it is damaged in any way – switch off, withdraw the mains plug and consult your dealer.

WARNING – excessive sound pressure from earphones or headphones can cause hearing loss.

ABOVE ALL – NEVER let anyone, especially children, push or hit the screen, push anything into holes, slots or any other openings in the case.

NEVER guess or take chances with electrical equipment of any kind – it is better to be safe than sorry.

Installation and important information

Where to install

Locate the television away from direct sunlight and strong lights, soft, indirect lighting is recommended for comfortable viewing. Use curtains or blinds to prevent direct sunlight falling on the screen.

Place the TV on a stable, level surface that can support the weight of the TV. **In order to maintain stability and prevent it falling over, secure the TV to the level surface using the strap located under the table top stand, or to a wall using a sturdy tie to the clip on the back of the table top stand.**

The LCD display panels are manufactured using an extremely high level of precision technology; however, sometimes some parts of the screen may be missing picture elements or have luminous spots. This is not a sign of a malfunction.

Make sure the television is located in a position where it cannot be pushed or hit by objects, as pressure will break or damage the screen. Also please be certain that small items cannot be inserted into slots or openings in the case.

Cleaning the screen and cabinet...

Turn off the power, and clean the screen and cabinet with a soft, dry cloth. We recommend that you **do not** use any proprietary polishes or solvents on the screen or cabinet as this may cause damage.

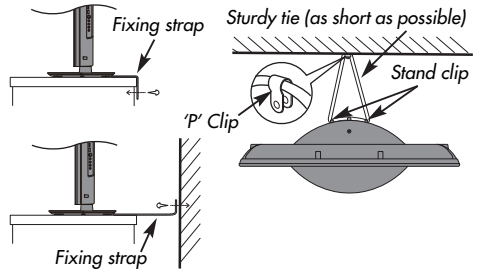

Stand style is dependent on model

Please take note

The digital reception function of this television is only effective in the countries listed in the "Country" section of the "SETUP" menu. Depending on country/area, some of this television's functions may not be available. Reception of future additional or modified services can not be guaranteed with this television.

If stationary images generated by 4:3 broadcasts, text services, channel identification logos, computer displays, video games, on screen menus, etc. are left on the television screen for any length of time, they could become conspicuous. It is always advisable to reduce both the brightness and contrast settings.

Very long, continuous use of the 4:3 picture on a 16:9 screen may result in some retention of the image at the 4:3 outlines. This is not a defect of the LCD TV and is not covered under the manufacturer's warranty. Regular use of other size modes (eg: Super Live) and varying the "side panel" brightness (if available on the model) will prevent permanent retention.

EXCLUSION CLAUSE

Toshiba shall under no circumstances be liable for loss and/or damage to the product caused by:

- i) fire;
- ii) earthquake;
- iii) accidental damage;
- iv) intentional misuse of the product;
- v) use of the product in improper conditions;
- vi) loss and/or damage caused to the product whilst in the possession of a third party;
- vii) any damage or loss caused as a result of the owner's failure and/or neglect to follow the instructions set out in the owner's manual;
- viii) any loss or damage caused directly as a result of misuse or malfunction of the product when used simultaneously with associated equipment;

Furthermore, under no circumstances shall Toshiba be liable for any consequential loss and/or damage including but not limited to the following, loss of profit, interruption of business, the loss of recorded data whether caused during normal operation or misuse of the product.

NOTE: A Toshiba wall bracket or stand, where available, must be used.

The remote control

Simple at-a-glance reference for your remote control.

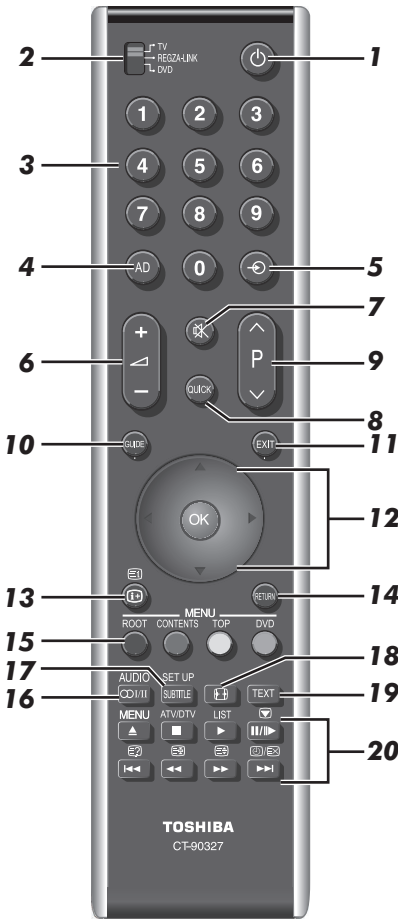

- 1 For On/Standby mode (T/R/D)*
- 2 To select device mode (T/R/D)
- 3 Number buttons (T/R/D)
- 4 Switch the Audio Description On/Off (T)
- 5 To select external input sources (T)
To select line input (R/D)
- 6 To alter the TV volume (T/R/D)
- 7 To mute the TV sound (T/R/D)
- 8 To access Quick Menu (T)
- 9 To change programme positions (T/R)
To change text pages (T)

- 10 To display the digital on-screen Programme Guide (T)
- 11 To exit menus (T)
- 12 When using menus, the arrows move the cursor on the screen up, down, left or right. Press **OK** to confirm your selection (T/R/D)
- 13 To display on-screen information (T/R/D)
To access index page in Text mode (T)
- 14 To return to previous menu (T/R/D)
- 15 **Colour buttons** Text and interactive service control buttons (T)
ROOT To display Root Menu (R)
CONTENTS To display Contents Menu (R)
TOP To access Top Menu (R/D)
DVD DVD Menus (R/D)
- 16 **CD/II** Stereo/bilingual transmissions (T)
AUDIO To access Audio menu (R/D)
- 17 **SUBTITLE** Digital Subtitles or Analogue TEXT Subtitle pages if available (T)
SET UP To access Setup menu (R/D)
- 18 Widescreen viewing (T/R/D)
- 19 To call up text services (T)
- 20 **When in TV mode:**
MENU On-screen menus
ATV/DTV To switch between ATV (analogue television) and DTV (digital television)
LIST To switch between TV and Radio programmes when in digital mode
 Picture still
 Analogue time display
When in Text mode:
 To reveal concealed text
 To hold a wanted page
 To enlarge text display size
 To select a page whilst viewing a normal picture

When using the Programme Guide:

- 24 hours
- + 24 hours
- 1 page
- + 1 page

REGZA-LINK or DVD mode:

- press to EJECT
- press to STOP
- press to PLAY
- press to PAUSE/STEP
- press to SKIP-BACK
- press to REWIND
- press to FAST FORWARD
- press to SKIP-FORWARD

* T=TV mode, R=REGZA-LINK mode, D=DVD mode

Inserting batteries and effective range of the remote

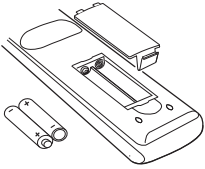

Remove the back cover to reveal the battery compartment and make sure the batteries are inserted the proper way. Suitable battery types for this remote are AAA, IEC R03 1.5V.

Do not combine a used, old battery with a new one or mix battery types. Remove dead batteries immediately to prevent acid from leaking into the battery compartment. Dispose of them in accordance with instructions on page 59 of this manual. **Warning:** batteries must not be exposed to excessive heat such as sunshine, fire or the like.

The performance of the remote control will deteriorate beyond a distance of five metres or outside an angle of 30 degrees from the centre of the television. If the operating range becomes reduced, the batteries may need replacing.

Connecting external equipment

Before connecting any external equipment, turn off all main power switches. If there is no switch, remove the mains plug from the wall socket.

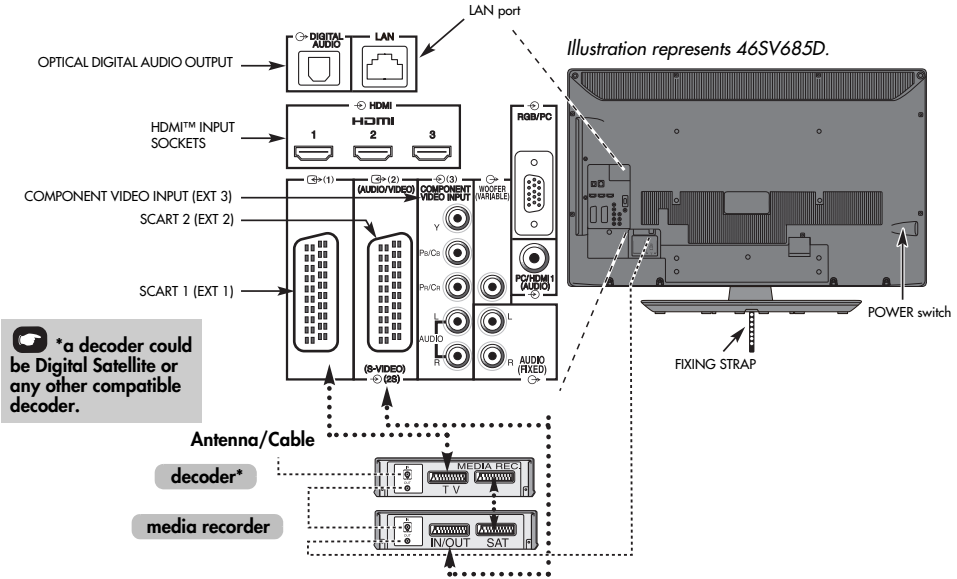

Aerial cables:

Connect the aerial to the socket on the rear of the television. If you use a decoder* and/or a media recorder, it is essential that the aerial cable is connected through the decoder and/or through the media recorder to the television.

SCART leads:

Connect the video recorder IN/OUT socket to the television. Connect the decoder TV socket to the television. Connect the media recorder SAT socket to the decoder MEDIA REC. socket.

Before running **Auto Tuning**, put your decoder and media recorder to **Standby**.

The phono sockets alongside the COMPONENT VIDEO INPUT sockets will accept L and R audio signals.

The Digital Audio Output socket enables the connection of a suitable surround sound system. **NOTE: this output is always active.**

HDMI™ (High-Definition Multimedia Interface) is for use with a DVD decoder or electrical equipment with digital audio and video output.

For acceptable video or PC signal formats through the HDMI terminals, see page 61.

NOTE: Although this television is able to connect to HDMI equipment, it is possible that some equipment may not operate correctly.

LAN port is used to connect the TV to your home network.

A wide variety of external equipment can be connected to the back of the television; therefore, the relevant owner's manuals for all additional equipment must be referred to for exact instructions.

We recommend **SCART 1** for a decoder and **SCART 2** for a media recorder.

If connecting S-VIDEO equipment, set the **INPUT** for **EXT 2**. See page 49.

If the television automatically switches over to monitor external equipment, return to normal television by pressing the desired programme position button. To recall external equipment, press  to select between **DTV**, **EXT 1**, **EXT 2**, **EXT 3**, **HDMI 1**, **HDMI 2**, **HDMI 3**, **HDMI 4**, **PC** or **ATV**.

When the external input mode is selected while viewing DTV mode, the SCART socket does not output video/audio signals. The SCART output will also be muted in EPG mode.



Manufactured under license from Dolby Laboratories.

Dolby and the double-D symbol are registered trademarks of Dolby Laboratories.



HDMI, the HDMI logo, and High-Definition Multimedia Interface are trademarks or registered trademarks of HDMI Licensing, LLC.

INSTAPORT™ and INSTAPORT logo are trademarks of Silicon Image, Inc. in the United States and other countries.

Connecting an HDMI™ or DVI device to the HDMI input

The HDMI input on your television receives digital audio and uncompressed digital video from an HDMI source device or uncompressed digital video from a DVI (Digital Visual Interface) source device.

This input is designed to accept HDCP (High-Bandwidth Digital-Content Protection) programme material in digital form from EIA/CEA-861-D-compliant [1] consumer electronic devices (such as a set-top box or DVD player with HDMI or DVI output). For acceptable video signal formats, see page 61.

NOTE:

- Some early HDMI equipment may not work properly with your latest HDMI TV, due to the adoption of a new standard. Please unplug your HDMI cable first and then try setting the following options (**Lip Sync**, **INSTAPOINT™**) to "Off". Your early HDMI source should operate properly with your television. See page 50.
- Supported Audio format: Linear PCM, sampling rate 32/44.1/48kHz.

To connect an HDMI device

Connect an HDMI cable (type A connector) to the HDMI terminal.

For proper operation, it is recommended that you use an HDMI cable with the HDMI Logo (**HDMI**).

- If your HDMI connection is capable of 1080p and/or your television is capable of refresh rates greater than 50Hz, you will need a Category 2 cable. Conventional HDMI/DVI cable may not work properly with this mode.
- HDMI cable transfers both video and audio. Separate analogue audio cables are not required (see illustration).
- See "HDMI 1 Audio" on page 50.

The HDMI 4 terminal is located on the side of the television.

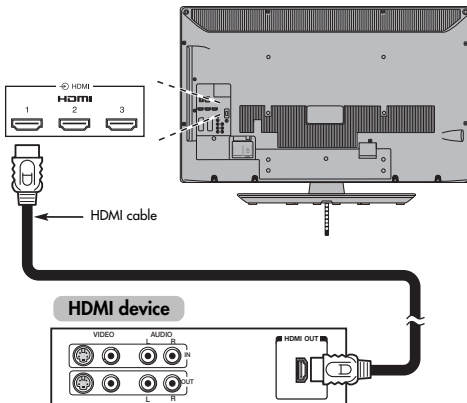

To view the HDMI device video, press the  button to select HDMI 1, HDMI 2, HDMI 3 or HDMI 4 mode.

To connect a DVI device

Connect an HDMI-to-DVI adapter cable (HDMI type A connector) to the HDMI 1 terminal and audio cables to the PC/HDMI1 (AUDIO) socket (see illustration).

- The recommended HDMI-to-DVI adapter cable length is 6.6 ft (2m).
- An HDMI-to-DVI adapter cable transfers video only. Separate analogue audio cables are required.
- See "HDMI 1 Audio" on page 50.

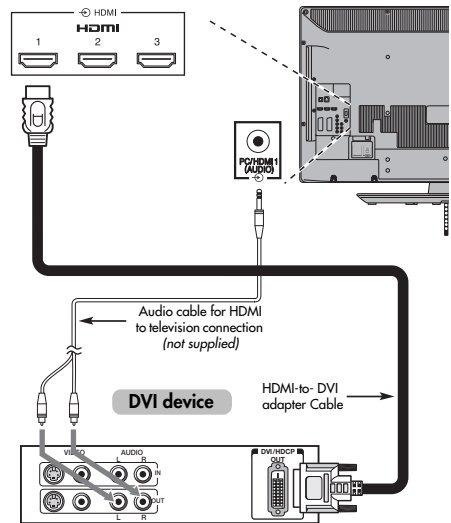

NOTE:

To ensure that the HDMI or DVI device is reset properly, it is recommended that you follow these procedures:

- When turning on your electronic components, turn on the television first, and then the HDMI or DVI device.
- When turning off your electronic components, turn off the HDMI or DVI device first, and then the television.

[1] EIA/CEA-861-D compliance covers the transmission of uncompressed digital video with high-bandwidth digital content protection, which is being standardized for reception of high-definition video signals. Because this is an evolving technology, it is possible that some devices may not operate properly with the television. HDMI, the HDMI logo and High-Definition Multimedia Interface are trademarks or registered trademarks of HDMI Licensing LLC.

REGZA-LINK connection

You can control the basic functions of connected audio/video devices using the television's remote control if you connect a REGZA-LINK compatible AV amplifier or playback device. For an explanation of setup and operations, see pages 51–52.

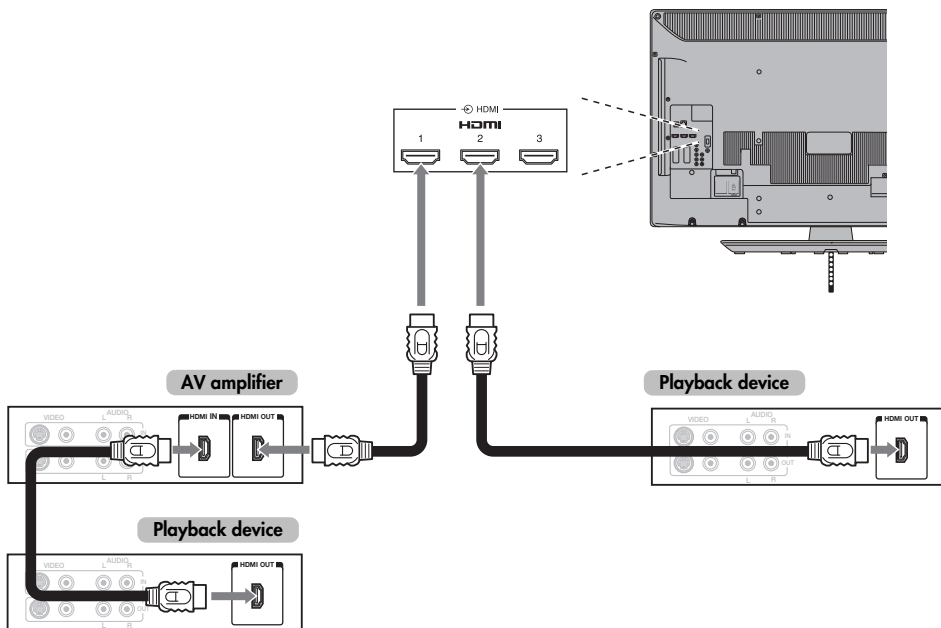

For the setup shown above, you will need three HDMI cables (see page 9).

NOTE:

- If several devices are connected, the REGZA-LINK feature may not operate properly.
 - For proper operation, it is recommended that you use HDMI cables with the HDMI Logo (**HDMI**).
 - The HDMI 4 terminal is located at the side of the television.
 - This function is available with one PC and one AV amplifier.
- This function is available when one PC and one AV amplifier are connected separately. However, it may not operate properly if the PC is connected via the AV amplifier.

Before controlling the device(s):

- After completing the above connections, set the REGZA-LINK Setup menu as you desire (see page 51).
- The connected devices must also be set. For details, see the operation manual for each device.
- The REGZA-LINK feature uses CEC technology as regulated by the HDMI standard.
- This feature is limited to models incorporating Toshiba's REGZA-LINK. However, Toshiba is not liable for those operations. Refer to individual instruction manuals for compatibility information.

Connecting a computer

With either an RGB/PC or an HDMI connection, you can watch your computer's display on the television and hear the sound from the television's speakers.

To connect a PC to the RGB/PC terminal

When connecting a PC to the RGB/PC terminal on the television, use an analogue RGB (15-pin) computer cable and a PC audio cable for the PC/HDMI1 (AUDIO) socket. Select **PC** from the **PC/HDMI 1 Audio** options in the **AV Connection** menu located in the **SETUP** menu.

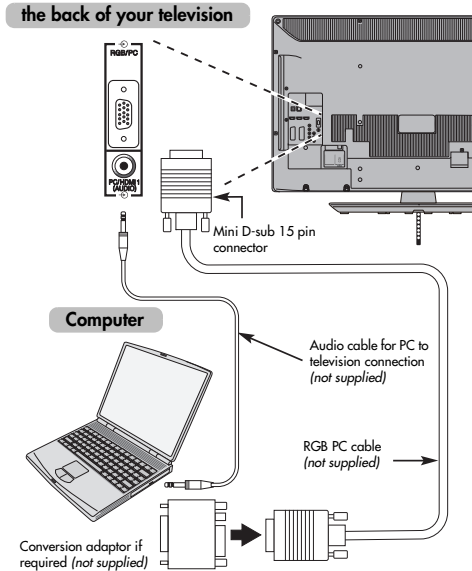

To use a PC, set the monitor output resolution on the PC before connecting it to the television. For acceptable PC signal formats, see page 60.

To display the optimum picture, use the PC setting feature (see page 48).

NOTE:

- The PC audio input terminal on the television is shared with the HDMI 1 analogue audio input terminal (see page 50).
- Some PC models cannot be connected to this television.
- An adapter is not needed for computers with a compatible mini D-sub 15-pin terminal.
- Depending on the DVD's title and the specifications of the PC on which you are playing the DVD-Video, some scenes may be skipped or you may not be able to pause during multi-angle scenes.

- A band may appear at the edges of the screen or parts of the picture may be obscured. This is due to scaling of the picture by the set, it is not a malfunction.
- When PC input mode is selected, some of the television's features will be unavailable e.g. **Manual Settings** in the **SETUP** menu, **Colour**, **Tint**, **Sharpness** and **Black/White Level** in the **PICTURE** menu.
- If connecting a certain PC model with a unique PC signal, the PC signal may not be detected correctly.

To connect a PC to the HDMI terminal

When connecting a PC to the HDMI terminal on the television, use an HDMI-to-DVI adapter cable and an analogue audio cable.

If connecting a PC with an HDMI terminal, use an HDMI cable (type A connector). A separate analogue cable is not necessary (see page 9).

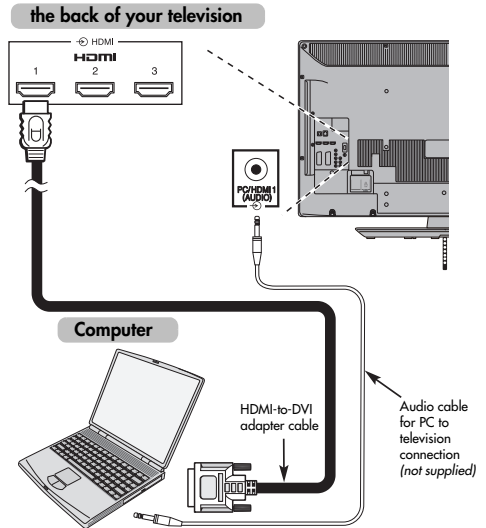

For acceptable PC and video signal formats, see page 61.

NOTE:

- The edges of the images may be hidden.
- If connecting a certain PC model with a unique PC signal, the PC signal may not be detected correctly.

Connecting a home network

The LAN port allows your Toshiba TV to connect to your home network. You can use this revolutionary home entertainment networking system to access photo, video and audio files that are stored on a DLNA server and play/display them on your TV. For supported formats, see page 36.

Installing the ULCS application

In order for your TV to play files stored on a PC, if you do not have the DLNA server you can do with your PC which is installed ULCS application (supplied). ULCS is software that allows files to be shared between playback equipment and a home network, or between two or more PCs.

Install the ULCS software Limited Edition (supplied). To operate the PC as a DLNA server, follow the instructions in the installation manual on the CD-ROM.

The software on the supplied CD is a Limited Edition without any customer support. For more information and to upgrade it to a full professional version please visit:

<http://www.transotechnology.co.jp/products/soft/ucs/>

NOTE:

- The TV's home network feature is compatible with Microsoft® Windows® XP/Vista.
- The TV's home network connection allows access to file sharing only. You will NOT be able to use the TV to access the Internet.
- If you use a hub or switch to connect the TV to your home network, you may not be able to use the automatic setup and have to manually set up the network address. See page 53.
- If you use a router with built-in DHCP functionality, use the automatic setup. Manual setup may not work.
- If you connect the TV and PC directly, use Ethernet crossover cable.

To connect the TV to a home network

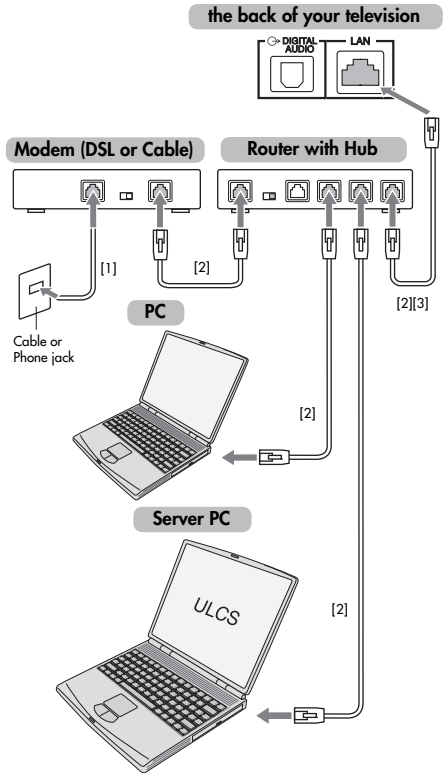

[1] Coaxial or telephone cable (depending on your modem type)

[2] Standard LAN cable

[3] Do NOT connect a phone jack directly to the TV's LAN port.

Controls and input connections

A wide variety of external equipment can be connected to the input sockets on the side of the television. Whilst all the necessary adjustments and controls for the television are made using the remote control, the buttons on the television may be used for some functions.

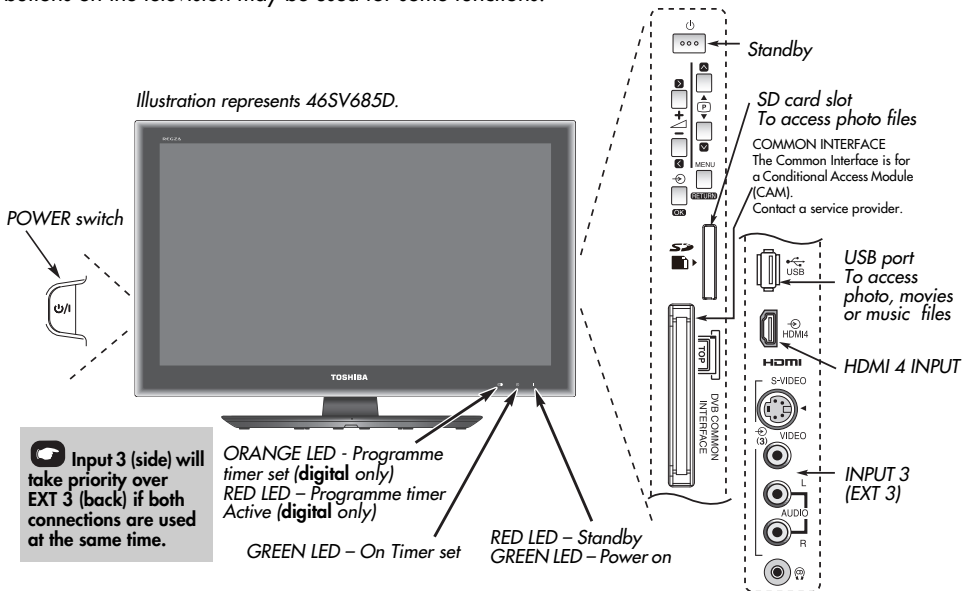

Switching on

If the RED LED is unlit, check that the mains plug is connected to the power supply and press the $\psi/1$ (POWER) button on the left side of the television to switch the television on. If the picture does not appear, press ψ on the remote control. It may take a few moments. The GREEN LED will be lit.

To put the television into Standby, press ψ on the remote control. To view the television, press ψ again. The picture may take a few seconds to appear.

Using the remote control

Press **MENU** on the remote control to display the menu.

The menu appears as a list of five topics. As each symbol is selected by pressing \blacktriangleleft or \blacktriangleright on the navigation ring on the remote control, its respective options will appear below.

NOTE: The same menu is displayed in DTV (Digital TV) and ATV (Analogue TV) modes; however, some items are greyed out in each case.

To operate the menu, press \blacktriangle and \blacktriangledown on the remote control to move up and down and press \blacktriangleleft or \blacktriangleright to select your desired setting. Follow the on-screen instructions. The functions of each menu are described in detail throughout the manual.

Using the controls and connections

To alter the volume press \blacktriangle +.

To alter the programme position press \blacktriangledown [P] \blacktriangle .

Press **MENU** and \blacktriangleright , \blacktriangleleft , \wedge or \vee to control the sound and picture options.

Press **MENU** to finish.

An S-video cable provides better picture performance than a composite video cable. If you connect an S-Video cable to **EXT 3**, be sure to disconnect the standard (composite) video cable or the picture performance will be unacceptable.

Media Player feature provides access to photos, movies or music files stored on a USB storage device, SD memory card (for photos only) or networked server PC connected via the LAN port.

To select an external input, press ψ until the appropriate input source is selected as described on page 49.

Please always refer to the owner's manual of the equipment to be connected for full details.

NOTE: Interactive video games that involve shooting a "gun" at an on-screen target may not work with this TV.

- DivX[®] is a registered trademark of DivX, Inc., and is used under license.

-  SD Logo is a trademark

Startup Application

Before switching on the television, put your decoder and media recorder, if applicable, to **Standby**.

To set up the television, use the buttons on the remote control as detailed on page 6.

Quick Setup

- 1 Press the **OK** button. The **Quick Setup** screen will appear. This screen will appear the first time that the television is switched on and each time **Reset TV** is selected.

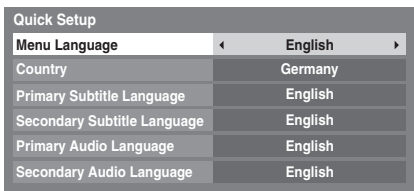

- 2 Highlight **Menu Language** and press **◀** or **▶** to select the menu language.
- 3 Press **▼** to highlight **Country** and **◀** or **▶** to select. The television is now set up to tune the stations for the selected country.

NOTE:

- The following display menus will differ slightly according to the country you selected.
- If there is not a country that you want to select in the list or you want to view DTV programmes but **DTV** is not selectable, select **Others**.

- 4 Press **OK**, and the **Location** screen will appear.

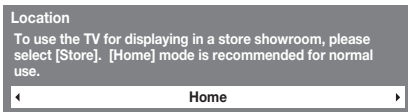

- 5 Press **◀** or **▶** to select **Home** or **Store**. For normal home use, select **Home** (skip step 6).
- 6 Press **OK**. If **Store** is selected in step 5, the **Auto Demo** screen will appear. Press **◀** or **▶** to select **On** to use the demo.
- 7 Press **OK**. If the **Ant/Cable In** screen appears, press **◀** or **▶** to select **Antenna** or **Cable**.



- 8 Press **OK**, and the **Auto Tuning** start up screen will appear with the option to select between **DTV and ATV**, **DTV** or **ATV** if available. Use **◀** or **▶** to select the appropriate mode.
- 9 Press **▼** or **▲** to highlight **Start Scan**, and then press **OK**.

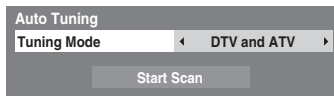

NOTE: If **Cable** is selected in step 7, additional setting options appear in the **Auto Tuning** screen. See “Ant/Cable In” section.

The television will start to search for available **DTV** and/or **ATV** channels. The progress bar will indicate the scan status.

You must allow the television to complete the search.

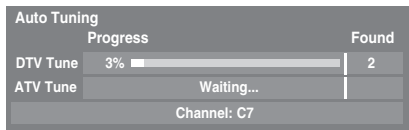

When the search is complete, the television will automatically select position one.

The **Auto Tuning** screen will display the total number of services found.

- 10 Press **◀** or **▶** to view the **DTV** (digital channel) or **ATV** (analogue channel) lists.
- 11 Use **▼** or **▲** to move through the list to select a channel, and then press **OK** to view.

In **ATV** mode, some areas may receive duplicate stations. There may not be a clear picture or the signal may be weak, so the station order can be changed using **ATV Manual Tuning**.

REMEMBER: Press **ATV/DTV** at any time to select between **ATV** and **DTV** (DTV TV/DTV RADIO/DTV TEXT if available) modes.

NOTE: The time will be set automatically by transmission but can be advanced or decreased by using **Local Time Setting** in the **DTV Settings** screen.

PLEASE NOTE

The **Reset TV** menu can also be accessed at any time from the **SETUP** menu.

Ant/Cable In (if available)

From this menu, you can set the RF input configuration to cable.

- 1** Press **MENU**, and select **SETUP** menu.
- 2** Use **▼** to highlight **Ant/Cable In** and use **◀** or **▶** to select **Antenna** or **Cable**.

NOTE: When you attempt to change the **Ant/Cable In** setting, a warning message will appear followed by PIN entry (if PIN has been set) and a prompt for **Auto Tuning**.

- 3** When **Ant/Cable In** is set to **Cable**, the following setting options will be provided in the **Auto Tuning** screen.

Press **▲** or **▼** to select an item, and then press **◀** or **▶** to select your desired option.

Auto Tuning	
Tuning Mode	DTV and ATV
Start Scan	
DTV	
Scan Type	◀ Quick Scan ▶
Start Frequency	Auto
End Frequency	Auto
Modulation	Auto
Symbol Rate	Auto
Network ID	Auto

With the exception of **DTV Scan Type** and **DTV Modulation** items, all of the following items will have 2 operating modes. The first is **Auto** where the values for each item are preset by the system. The second is an **Input** mode where you will be able to enter a single value in place of the pre-set value. If no channel is currently tuned and the **Input** state is chosen, a system default value will be shown. However, if a channel is currently tuned when the item is accessed, the value of the current channel will be displayed.

DTV Scan Type:

This item determines whether a **Quick Scan** or a **Full Scan** will be executed.

The **Quick Scan** is a simplified version of the **Full Scan** that is designed to complete in less time.

DTV Start Frequency:

This sets the frequency from which the scan will begin.

DTV End Frequency:

This sets the frequency at which the scan will end.

* Valid entry range for frequency items is 113.000-858.00 for C-Book/Other and 114.000-858.00 for Nordig-C. If numbers outside of this range are entered, the values will automatically be set to the min. or max. valid value as appropriate.

DTV Modulation:

You can choose from five QAM modulation settings.

DTV Symbol Rate:

This is the baud rate (KS/s) of the scan.

* Valid entry range for Symbol Rate is 4000-7200. If a number outside of this range is entered, the value will be automatically set to the min. or max. valid value as appropriate.

DTV Network ID:

This is the Network ID to be utilized for the scan. This item is greyed out when DTV Scan Type is set to "Full Scan".

* Valid entry range for Network ID is 1-65535. If a number outside of this range is entered, the value will be automatically set to the min. or max. valid value as appropriate.

Auto Tuning

NOTE: As new services are broadcast, it will be necessary to re-tune the television in order to view them.

Auto Tuning will completely re-tune the television and can be used to update the channel list. **It is recommended that Auto Tuning is run periodically to ensure that all new services are added.** All current channels and settings, i.e. locked channels, will be lost.

- 1 Press **MENU** and use ◀ or ▶ to select **SETUP** menu. Use ▼ to highlight **Auto Tuning**. Press **OK**.

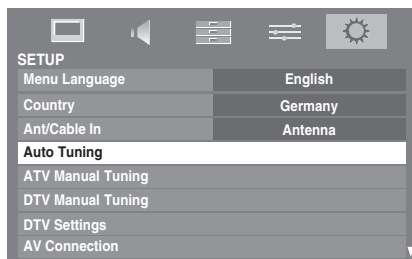

- 2 A screen will appear warning that previous programmes and settings will be deleted.

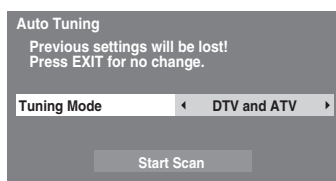

Use ◀ or ▶ to select **DTV and ATV**, **DTV** or **ATV**, if available, then highlight **Start Scan** and press **OK** to continue with the **Auto Tuning**.

NOTE: If you have selected "Others" for the **Country** field in the **SETUP** menu, and select a tuning mode other than "DTV", choose the optimum ATV broadcasting system (B/G, I, D/K or L).

The television will start to search for all available DTV and/or ATV services.

You must allow the television to complete the search.

When the search is complete, the **Auto Tuning** screen will display the services found.

- 3 Use ▼ or ▲ to move through the list to select a channel, and then press **OK** to view.

ATV Manual Tuning

Tuning

The television can be tuned-in manually using **ATV Manual Tuning**. For example, you might use the feature if the television cannot be connected to a media recorder/decoder with a SCART lead or when you want to tune-in a station on another **System**.

Use ◀ and ▶ to move across the screen and select any of the **ATV Manual Tuning** options. Then use ▲ or ▼ to adjust the settings.

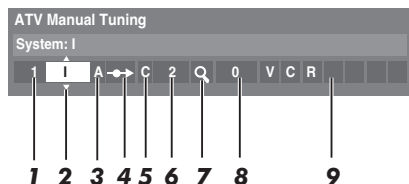

- 1 **Position:**
The number to be pressed on the remote control to tune the channel.
- 2 **System:**
Specific to certain areas.
- 3 **Colour System:**
Factory set to Auto, should only be changed if problems are experienced, i.e. NTSC input from external source.
- 4 **Skip:**
Set Skip to On (↔) or Off (↔) for the selected channel. See page 18
- 5 **Signal Class:**
The channel classification.
- 6 **Channel:**
The channel number on which a station is being broadcast.
- 7 **Search:**
Search up and down for a signal.
- 8 **Manual Fine Tuning:**
Only used if interference/weak signal is experienced. See page 56.
- 9 **Station:**
Station identification. Use the ▲ or ▼ and ◀ or ▶ buttons to enter up to seven characters.

To allocate a position on the television for a decoder and media recorder: turn the decoder on, insert a pre-recorded film in the media recorder, press **PLAY**, and then manually tune.

- 1** Press **MENU** and using **◀** or **▶** select the **SETUP** menu. With **▼** highlight **ATV Manual Tuning** and press **(OK)** to select.

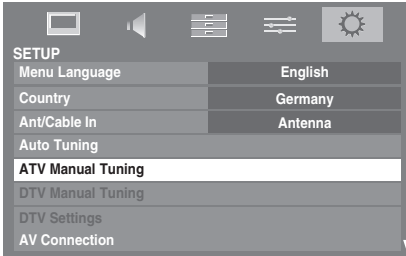

- 2** Use **▲** or **▼** to highlight the desired position. We suggest **Pos. 0** for a media recorder.

Pos.	Channel	Station
1	C2	
2	S10	
3	C7	
4	S40	
5	C22	
6	C25	
7	C28	
8	C30	

Different **Channel** numbers may be displayed.

- 3** Press **(OK)** to select. If the channel chosen for the media recorder is set to skip, Skip should be removed before storing.
- 4** Press **▶** to select **System** and use **▲** or **▼** to change if required.



- 5** Then press **▶** to select **Search**.
- 6** Press **▲** or **▼** to begin the search. The search symbol will flash.



- 7** Each signal will show on the television. If it is not your media recorder, press **▲** or **▼** again to restart the search.
- 8** When your media recorder signal is found, press **▶** to move along to **Station**. With **▲**, **▼**, **◀** and **▶** put in the required characters, e.g. **VCR**.

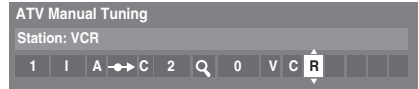

- 9** Press **(OK)** to save.
- 10** Repeat for each **position** you want to tune, or press **RETURN** to return to the list of channels and select the next number to tune.
- 11** Press **EXIT** when you have finished.
- 12** To name external equipment, e.g. DVD on EXT 2, press **↵** to select **↵2**, then select **Manual Settings** from the **SETUP** menu.
- 13** Press **▶** to select **Label** then using **▲**, **▼**, **◀** and **▶** put in the required characters, and then press **(OK)** to save.



PLEASE NOTE

This television has direct channel entry if the channel numbers are known. Select the **ATV Manual Tuning** screen in **Step 3**. Enter the **Position number**, the **System**, then **C** for standard (terrestrial) channels or **S** for cable channels and the **Channel number**. Press **(OK)** to save.

Skip

To prevent certain channels from being viewed, positions can be skipped.

- 1 Select **ATV Manual Tuning** from the **SETUP** menu.
- 2 Use **▲** or **▼** to highlight the position to be skipped and press **OK** to select.

ATV Manual Tuning		
Pos.	Channel	Station
1	C2	
2	S10	
3	C7	
4	S40	ABC1
5	C22	ABC1
6	C25	
7	C28	
8	C30	

- 3 Press **▶** to select **Skip**.
- 4 Use **▲** or **▼** to turn **Skip** on.
Press **OK**.
 on the screen indicates a skipped position.

ATV Manual Tuning		
Skip: On		
1	I A  C 2	Q 0

- 5 Press **RETURN** and repeat from **Step 2** or press **EXIT**.

Each position has to be *individually* selected. To turn **Skip** off, repeat the procedure for each position.

Skipped positions **cannot** be selected by **P▲** and **P▼** or by the controls on the television but **can** still be accessed by the number buttons on the remote control.

Sorting positions

Channels may be moved and saved to the position of your choice.

- 1 Select **ATV Manual Tuning** from the **SETUP** menu.
- 2 With the list of channels showing, use **▲** or **▼** to highlight the channel you want to move and press **▶**.

ATV Manual Tuning		
Pos.	Channel	Station
2	S10	
3	C7	
4	C40	ABC1
5	C22	ABC1
1	C2	
6	C25	
7	C28	
8	C30	

- 3 Use **▲** or **▼** to move through the list to your preferred position. As you do so, the other channels will move to make room.
- 4 Press **◀** to save your move.
Repeat as necessary, and then press **EXIT**.

DTV Manual Tuning

NOTE: This feature varies depending on the **Ant/Cable In** setting.

Manual Tuning

This feature is available for service engineers or can be used for direct channel entry if the multiplex channel is known.

- 1 Select **DTV Manual Tuning** from the **SETUP** menu and press **OK**.

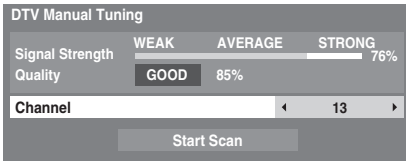

- 2 Enter the multiplex number using the number buttons or use **◀** or **▶** to adjust the number up or down.
- 3 Highlight **Start Scan**, and then press **OK**. The television will automatically search for that multiplex.

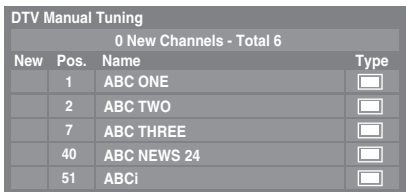

When the multiplex is found, any channels that are not currently in the channel list will be added and the channel information at the top of the screen will be updated.

- 4 Repeat as necessary. Press **EXIT** to finish.

Manual Tuning for DVB-C

When **Ant/Cable In** is set to **Cable**, **DTV Manual Tuning** items are as follows:

Frequency – input a specific frequency to be scanned

Modulation – choose from one of five QAM modulation options

Symbol Rate – input a specific baud rate (KS/s) to be used for the manual scan

DTV Settings

Channels

The channel order may be changed to suit your personal preference.

- 1 Select **DTV Settings** from the **SETUP** menu and press **OK**.
- 2 Select **Channels** and press **OK**.

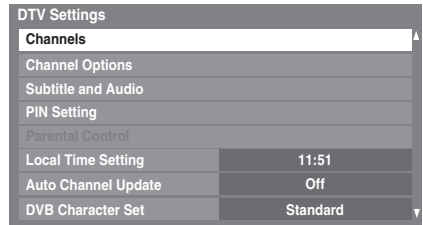

- 3 With the list of channels showing, use **▼** or **▲** to highlight the channel you want to move and press **▶**.



- 4 Use **▼** or **▲** to move through the list to your preferred position. As you do so, the other channels will move to make room.
- 5 Press **◀** to save your move. Repeat as necessary, then press **EXIT**.

To renumber for the highlighted channel, press the **RED** button on the remote control.

Edit the channel number using the number buttons and press **OK**.

Pos.	Name	TV
1	ABC ONE	
2	ABC TWO	
7	ABC THREE	
30	CABC Channel	
40	ABC NEWS 24	
5	ABCi	

Auto Channel Update

If the **Auto Channel Update** is set to **On**, when the TV is in standby mode, Digital Tuning is automatically executed and any new channels are saved.

- 1 Select **DTV Settings** from the **SETUP** menu and press **OK**.
- 2 Press **▼** to select **Auto Channel Update** and use **◀** or **▶** to select **On**.

DVB Character Set

This feature allows you to manually set the character set (**Standard** = Table 0, **West** = Table 5 or **Latin alphabet 9**) to be used for DVB-C or DVB-T channels.

- 1 Select **DTV Settings** from the **SETUP** menu and press **OK**.
- 2 Press **▼** to select **DVB Character Set** and use **◀** or **▶** to select **Standard**, **West** or **Latin alphabet 9**.

Dynamic Scan

If the broadcast information has changed in your DVB-T receiving area, the TV screen will display the message "Broadcast information has changed. Would you like to rescan now?" please follow the message.

- 1 Select **DTV Settings** from the **SETUP** menu and press **OK**.
- 2 Press **▼** to select **Dynamic Scan** and use **◀** or **▶** to select **On**.

Location setting

You can select either **Home** or **Store** mode. **Home** is recommended for normal home use. Select **Store** when using the television for displaying in a shop, etc.

- 1 Select **Location** from the **SETUP** menu.
- 2 Press **◀** or **▶** to select **Home** or **Store**.

Analogue switch-off

This is a **digital** television which is integrated to allow the use of both **digital** and **analogue** services. However, during the lifetime of this set it is very likely that **analogue** services will be switched off to allow for more new **digital** services.

This 'switch-off' will happen in a number of phases, which will be advertised in your area well in advance. It is recommended that at each phase the television is re-tuned to ensure that existing and new **digital** services can be viewed without disruption.

General controls

Quick Menu

Quick Menu helps you access some options quickly, such as **Picture Mode**, **Picture Size**, **More Information**, **Sleep Timer** etc.

Press **QUICK** to display the **Quick Menu** and use **▲** or **▼** to select the option.

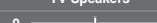
Quick Menu	
Picture Mode	AutoView
Picture Size	Super Live
More Information	
Sleep Timer	00:00
Media Player	
Photo Frame	
Speaker Preference	TV Speakers
Headphone Level	0 
System Information	

NOTE: **Quick Menu** items are different depending on the current mode.

Mode	Quick menu item	Description
When viewing a TV programme or pictures from the external input	Picture Mode	See page 27.
	Picture Size	See page 25.
	More Information	See page 43.
	Sleep Timer	See page 41.
	Media Player	See page 32.
	Photo Frame	See page 38
	Headphone Level	See page 23.
	Speaker Preference	See page 51.
	System Information	See page 47.
When using EPG	Genre Colour	See page 43.
	EPG Update/ Cancel EPG Update	See page 43.
When using Media Player (Photo Multi View)	Device Information	See page 36.
When using Media Player (Photo Single View, Slide Show)	Picture Size	See page 25.
	Interval Time	See page 33.
	Repeat	See page 33.
When using Media Player (Movie List)	Sort	See page 37.
	Repeat	See page 34.
	Device Information	See page 36.

Mode	Quick menu item	Description
When using Media Player (Movie Play)	PICTURE	See page 27.
	Picture Size	See page 25.
	SOUND	See page 22.
	Repeat	See page 34.
When using Media Player (Music List)	SOUND	See page 22.
	Sort	See page 37.
	Repeat	See page 35.
	Device Information	See page 36.
Photo Frame	Picture Size	See page 25.

Selecting positions



To select a position, use the numbered buttons on the remote control.

Positions can also be selected using **P** and **V**.

To display on-screen information such as position, input mode or stereo/mono signal, press . Press again to cancel.

The Time Display – analogue only

The time display facility allows the current (text service) time to be seen on the television screen.



Press /  whilst watching a normal television broadcast to see the time display from the broadcaster. It will remain on screen for about 5 seconds.



NOTE: This display may not be available in some cases.

Stereo and Bilingual transmissions

For ATV programmes

If stereo or dual language broadcasts are transmitted, the word Stereo or Dual will appear on the screen each time positions are changed, disappearing after a few seconds. If the broadcast is not in stereo, the word Mono will appear.

Stereo... Press /  to select **Stereo** or **Mono**.

Bilingual... Bilingual transmissions are rare. If they are transmitted, the word **Dual** will be displayed. Choose the required programme number and if the word **Dual** appears press /  to select **Dual 1**, **Dual 2** or **Mono**.

For DTV programmes

For stereo or dual mono broadcasts, press \odot I/II and use \blacktriangleleft or \blacktriangleright to select settings.

Mode Display	Pressing \blacktriangleright
\odot Stereo	Stereo \rightarrow Left \rightarrow Right
\bullet \odot Dual mono	Dual 1 \rightarrow Dual 2 \rightarrow Dual
\bigcirc Mono	–
\odot Multichannel	–

For multi-audio track broadcasts, press \odot I/II repeatedly to change the audio language (see 'Audio language' on page 46).

Sound controls

Volume controls and mute sound

Volume

Press \updownarrow or \updownarrow to adjust the volume.

Sound Mute

Press M once to turn the sound off and again to cancel.

Dual

If a programme or film is being broadcast with a soundtrack in more than one language, the **DUAL** feature allows selection between them.

- 1 Press **MENU** and \blacktriangleleft or \blacktriangleright to select **SOUND**.
- 2 Use \blacktriangledown to highlight **Dual**, and then press \blacktriangleleft or \blacktriangleright to choose between **Dual 1** or **Dual 2**.

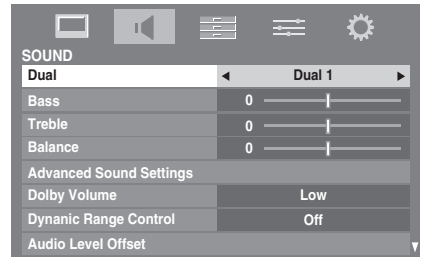

Bass, Treble and Balance

The sound controls are accessible in **digital** and **analogue** modes.

- 1 Select the **SOUND** menu.
- 2 Press \blacktriangledown to highlight **Bass**, **Treble** or **Balance** and \blacktriangleleft or \blacktriangleright to change the setting.

Advanced Sound Settings

Surround, Voice Enhancement, and Dynamic Bass Boost help to create an enhanced surround sound experience with deep, rich bass from stereo sound sources. Your TV's audio will sound fuller, richer, and wider.

- 1 In the **SOUND** menu, press ▼ to highlight **Advanced Sound Settings**, and then press (OK).
- 2 Press ▼ to highlight **Surround**, and then press ◀ or ▶ to select **Off**, **Spatial** or **Cinema**.

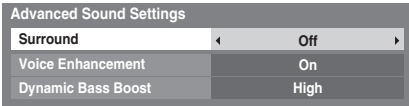

- 3 Press ▼ to highlight **Voice Enhancement**, and then press ◀ or ▶ to select **On**.
- 4 Press ▼ to highlight **Dynamic Bass Boost** and using ◀ or ▶ select the desired bass expansion level (**Off**, **Low** or **High**).

NOTE: **Ext. Woofer** is displayed instead of **Dynamic Bass Boost** when **Woofer** is set to **External** in the **AV Connection** menu. See 'Woofer setting' section on page 49.

Dolby Volume®

This feature provides a consistent sound volume regardless of programmes, channels or input sources.

- 1 In the **SOUND** menu, press ▼ to highlight **Dolby Volume**.
- 2 Press ◀ or ▶ to select **Low**, **High** or **Off**.

NOTE:

- The **Dolby Volume** setting influences the **Dynamic Range Control** and **Digital Audio Output** settings.
- If **Dynamic Range Control** is set to **On**, this feature will be disabled.

Dynamic Range Control

This feature allows control of audio compression for some digital TV programmes (MPEG-1 and MPEG-2 audio programmes are not supported).

- 1 In the **SOUND** menu, press ▼ to highlight **Dynamic Range Control**.
- 2 Press ◀ or ▶ to select **On** or **Off**.

NOTE: This feature is disabled when **Dolby Volume** is set to **Low** or **High**.

Audio Level Offset

Sometimes there can be large changes in volume when switching from a DTV 5.1ch to a DTV 2ch, an ATV channel, or an external input. Using the **Audio Level Offset** feature reduces these volume differences.

- 1 Set the volume level usually used when watching a DTV 5.1ch programme.
- 2 Tune to a channel which is DTV 2ch or ATV or an external input.
- 3 In the **SOUND** menu, press ▼ to highlight **Audio Level Offset** and press (OK).
- 4 Press ▼ to highlight an option, then use ◀ or ▶ to adjust the volume level.

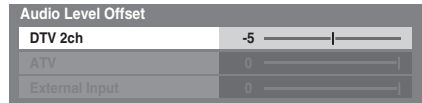

NOTE:

- The available item changes depending on the current input source. For example, while watching a DTV 2ch programme, only **DTV 2ch** is available and the other two items are greyed out in the menu. This allows you to easily adjust according to each condition.
- When watching a DTV 5.1ch programme, this feature is not available.

Headphone Settings

This setting is used to set the sound output when headphones are connected.

Speaker Link	Headphone	Speakers
On	Sound is output (◀ - + is available.)	No sound
Off	Sound is output (Headphone level menu is available.)	Sound is output (◀ - + is available.)

- 1 In the **SOUND** menu, press ▼ to highlight **Headphone Settings**, and then press (OK).
- 2 Press ▼ to highlight **Speaker Link** and use ◀ or ▶ to select **On** or **Off**.
- 3 If you select **Off**, then highlight **Headphone Level** and use ◀ or ▶ to adjust the headphone sound.



Audio Description

Audio Description is an additional narrative sound track for visually impaired individuals to understand and enjoy the story line more fully. If this function has been activated by pressing the AD key, the letters AD will be displayed in the channel banner when programmes contain AD content. You can choose to hear sound from the TV speakers and the headphone output or only from the headphone output.

- 1 From the **SOUND** menu, select **Audio Description** and press **OK**.
- 2 Highlight **Audio Description**, and then press **◀** or **▶** to select **On**.

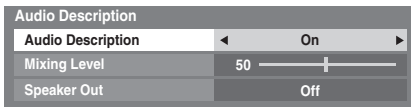

- 3 To adjust the level of the audio description sound to the main sound, highlight **Mixing Level** and use **◀** or **▶**.
- 4 Highlight **Speaker Out**, and then press **◀** or **▶** to select **On** or **Off**.

On: sound from both the headphone output and speakers.

Off: sound from the headphone output.

See "Headphone Settings" to adjust the headphone sound.

NOTE: This feature also applies to the sound from the DIGITAL AUDIO output and FIXED AUDIO output.

Widescreen viewing

Depending on the type of broadcast being transmitted, programmes can be viewed in a number of formats.

WIDE

Use this setting when watching a widescreen DVD, widescreen video tape or a 16:9 broadcast (when available). Due to the range of widescreen formats (16:9, 14:9, 20:9 etc.) black bars may be visible on the top and bottom of the screen.

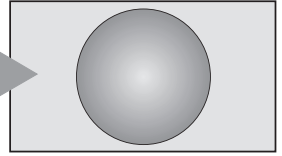

4:3

Use this setting to view a true 4:3 broadcast.

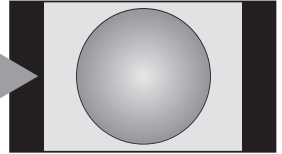

SUPER LIVE

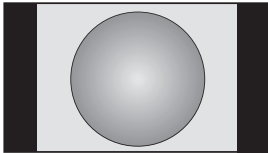

This setting will enlarge a 4:3 image to fit the screen by stretching the image horizontally and vertically, holding better proportions at the centre of the image. Some distortion may occur.

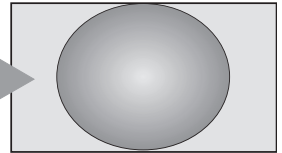

CINEMA

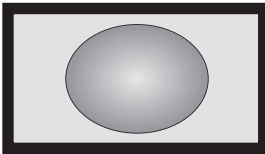

When watching 'all sides panel format' films/video tapes, this setting will eliminate or reduce the black bars at all sides of the screen by zooming in and selecting the image without distortion.

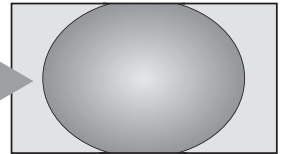

SUBTITLE

When subtitles are included on a letterbox format broadcast, this setting will raise the picture to ensure that all the text is displayed.

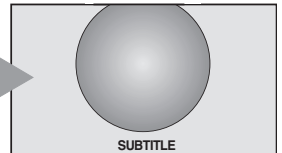

14:9

Use this setting when watching a 14:9 broadcast.

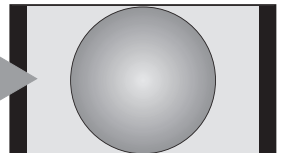

NATIVE

This setting will show the picture without over scan, i.e. WYSIWYG. However, movie playback (DivX files) from the USB device will be with over scan.

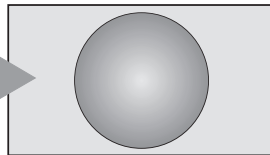

PC NORMAL

This setting will show the picture without over scan, i.e. WYSIWYG. This option is only available when watching a PC signal source via HDMI or PC terminal.

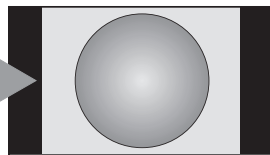

PC WIDE

This setting will show the picture without over scan and side panel. This option is only available when watching a PC signal source via HDMI or PC terminal.

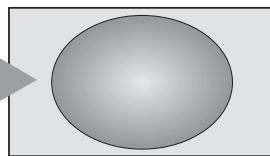

Dot by Dot

“Dot by Dot” is a non-scaling display. Depending on the input signal format, the picture is displayed with side panels and/or bars at the top and bottom (e.g. VGA input source).

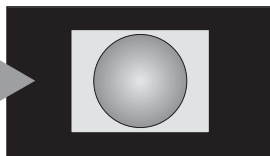

Small

This option is only available when watching a movie (DivX file) from a USB device.

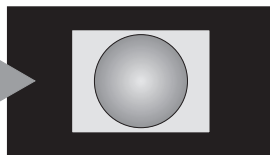

Press **QUICK**, highlight **Picture Size**, and then press **OK** to display the list of available widescreen formats. Use **▲** and **▼** to highlight the required format and **OK** to select.

AV format

Picture Size
Wide
Super Live
Cinema
4:3
Subtitle
14:9
Native

PC format

Picture Size
PC Normal
PC Wide
Dot by Dot

Using the special functions to change the size of the displayed image (i.e. changing the height/width ratio) for the purposes of public display or commercial gain may infringe on copyright laws.

Picture controls

Most of the picture controls and functions are available in both **digital** and **analogue** modes.
PLEASE NOTE: features not available will be greyed out.

Picture Position

The picture position may be adjusted to suit personal preference and can be particularly useful for external inputs.

- 1 In the **SETUP** menu, press ▼ until **Picture Position** is highlighted.

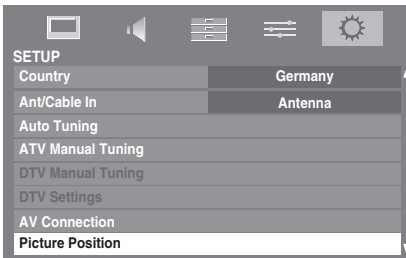

- 2 Press **OK** to view the options available for the picture format that has been selected.

- 3 Press ▲ and ▼ to select an option, then ◀ or ▶ to adjust the settings.

The options alter depending on the currently selected widescreen format and the input signal.

In **Cinema** mode:

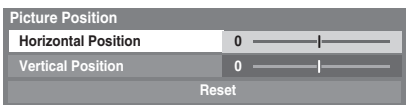

To return to the original factory settings, select **Reset** in the **Picture Position** menu and press **OK**.

Picture Mode

This television offers the choice of personalising the picture style.

AutoView, **Dynamic**, **Standard**, **Movie**, **Store**, **Game** and **PC** are preset options and affect many features/settings within the television.

NOTE:

- Because the **AutoView** mode automatically adjusts picture settings based on ambient light conditions and input signal content, the **Auto Brightness Sensor** and **Expert Mode** menus are greyed out when it is selected.
- **Store** mode is only available when **Location** is set to **Store**.
- **Game** mode is available in external input mode (other than aerial input). When you select **Game** mode, suitable widescreen formats will be selected.
- **PC** mode is available in RGB/PC input mode or HDMI input mode.

- 1 In the **PICTURE** menu, press ▼ to select **Picture Mode**.

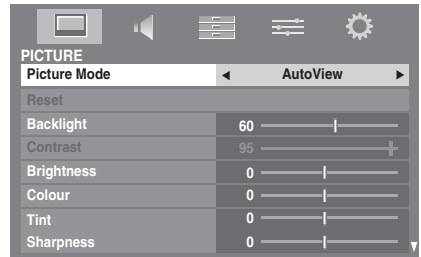

- 2 Press ◀ or ▶ to select the picture mode you prefer and press **OK**.

NOTE: The picture mode you select affects the current input only. You can select a different picture mode for each input.

Picture preferences

*You can customise current picture mode settings as desired. For example, while selecting "Dynamic", if you change the following items, such as **Backlight**, **Contrast**, **Brightness**, **Colour**, **Tint**, **Sharpness** and the **Advanced Picture Settings** items, your new settings are saved for "Dynamic" picture mode.*

- 1 In the **PICTURE** menu press ▼ to select either **Backlight**, **Contrast**, **Brightness**, **Colour**, **Tint** or **Sharpness** and press **OK**.

- 2 Press ◀ or ▶ to adjust the settings.

Reset

This feature resets all picture settings to the factory settings except **Picture Mode**.

NOTE: If no picture settings have been changed, **Reset** is not available.

- 1 In the **PICTURE** menu, press ▼ to select **Reset** and press **OK**.
- 2 A confirmation message will appear. Press ◀ or ▶ to select **Yes** and press **OK**.

3D Colour Management

When **3D Colour Management** is set to **On**, it allows the 'Base Colour Adjustment' feature to become available.

- 1 In the **PICTURE** menu, press ▼ to select **Advanced Picture Settings** and press **OK**.
- 2 Press ▼ to select **3D Colour Management**.

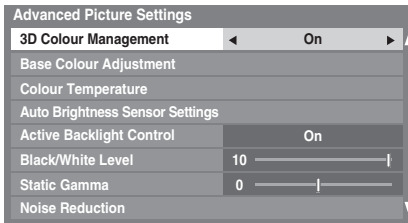

- 3 Press ◀ or ▶ to select **On** or **Off**, and then press **OK**.

Base Colour Adjustment

The **Base Colour Adjustment** feature allows the adjustment of individual colours to suit personal preference. This can be useful when using an external source.

- 1 In the **Advanced Picture Settings** menu, press ▼ to select **Base Colour Adjustment**, and then press **OK**.
- 2 Press ▲ or ▼ to select an option, and then press ▶ to move to the adjustment window.

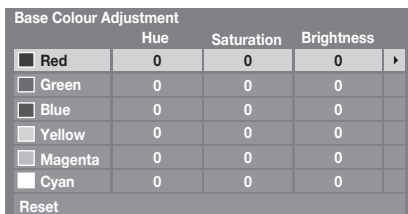

- 3 Press ◀ or ▶ to select **Hue**, **Saturation** or **Brightness**, and then press ▲ or ▼ to adjust the settings as required.

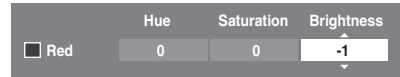

- 4 Press **OK** to return to the previous menu.
To return to the factory settings, select **Reset** and press **OK**.

Colour Temperature

Colour Temperature increases the 'warmth' or 'coolness' of the picture by increasing the red or blue tint.

- 1 In the **Advanced Picture Settings** menu, press ▼ to select **Colour Temperature** and press **OK**.
- 2 Press ◀ or ▶ to select the **Colour Temperature** setting (0 (warm) -10 (cool)).

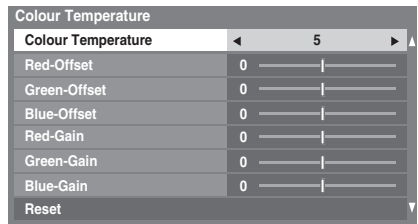

- 3 Press ▲ or ▼ to select an option you want to adjust, and then press ◀ or ▶ to adjust the settings.
- 4 Press **OK** to return to the previous menu.

To return the Colour Temperature settings to the factory defaults, select **Reset** and press **OK**.

NOTE: If **Picture Mode** is set to **AutoView**, you can adjust **Colour Temperature** only and the range will be -5 to +5.

Auto Brightness Sensor Settings

When the **Auto Brightness Sensor** is activated, it will automatically optimise the backlighting levels to suit ambient light conditions.

- 1 In the **Advanced Picture Settings** menu, press ▼ to select **Auto Brightness Sensor Settings** and press **OK**.
- 2 Press ◀ or ▶ to select **On** and press **OK**.

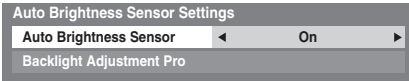

- 3 Press ▼ to select **Backlight Adjustment Pro** and press **OK**.
- 4 The **Backlight Adjustment Pro** window will appear. Press **OK** again to display the adjustment window.
- 5 Press ◀ or ▶ to select a point and press ▲ or ▼ to adjust the level.

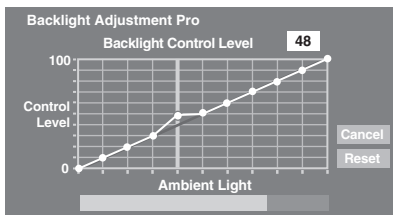

- 6 Press **OK** to fix the adjustment.
To cancel the adjustment when selecting a point, select **Cancel** and press **OK**.
To return the adjustments of all points to the factory defaults, select **Reset** and press **OK**.

LED Backlight Control

When **LED Backlight Control** is activated, it will automatically optimise the backlighting levels for dark scenes.

- 1 In the **Advanced Picture Settings** menu, press ▼ to select **LED Backlight Control**.
- 2 Press ◀ or ▶ to select **On** or **Off**.

Black/White Level

Black/White Level increases the strength of dark areas of the picture to improve the definition.

- 1 In the **Advanced Picture Settings** menu, press ▼ to select **Black/White Level**.
- 2 Press ◀ or ▶ to adjust the level. The effect depends on the broadcast and is most noticeable on dark colours.

Static Gamma

The **static gamma** feature allows you to adjust the levels of black in the picture.

- 1 In the **Advanced Picture Settings** menu, press ▼ to select **Static Gamma**.
- 2 Press ◀ or ▶ to adjust the level.

MPEG NR – Noise Reduction

When watching a DVD, the compression may cause some words or picture elements to become distorted or pixelated. Using the **MPEG NR** feature reduces this effect by smoothing out the edges.

- 1 In the **Advanced Picture Settings** menu, press ▼ to select **Noise Reduction** and press **OK**.
- 2 Press ▼ to select **MPEG NR**.



- 3 Press ◀ or ▶ to select **Low**, **Middle**, **High** or **Off** to suit your preference.

DNR – Digital Noise Reduction

DNR allows you to 'soften' the screen representation of a weak signal to reduce the noise effect.

- 1 Select **DNR** from the **Noise Reduction** menu.
- 2 Use ◀ or ▶ to select **Low**, **Middle**, **High**, **Auto** or **Off**. The differences may not always be noticeable (for the best result use lower settings as picture quality can be lost if the setting is too high).

Resolution+

The **Resolution+** feature allows you to adjust the clarity levels for your desired picture settings.

- 1 In the **Advanced Picture Settings** menu, press ▼ to select **Resolution+** and press **OK**.
- 2 In the **Resolution+** field, select **On**.



- 3 Press ▼ to highlight **Level**, and then press ◀ or ▶ to adjust the level.

NOTE:

- This feature may not work properly depending on the content.
- Adjustable range varies according to the Picture Mode you set.
- Noise may appear in the picture depending on the device connected to the TV (e.g. a device with a specific enhancer function).

Active Vision M200

This feature will reduce picture blur without decreasing image brightness, or adding flicker.

- 1 In the **Advanced Picture Settings** menu, press ▼ to select **Active Vision M200**.
- 2 Press ◀ or ▶ to select **On** or **Off**.

NOTE: When **Picture Mode** is set to **Game**, this feature will be greyed out and automatically set to **Off**.

Film Stabilization

The **Film Stabilization** feature allows the adjustment of motion smoothness.

- 1 In the **Advanced Picture Settings** menu, press ▼ to select **Film Stabilization**.
- 2 Press ◀ or ▶ to select **Standard**, **Smooth** or **Off**.

NOTE: When **Picture Mode** is set to **AutoView**, the **Film Stabilization** feature will have an additional "**Auto**" mode.

Expert Mode

This feature allows you to turn the colours red, green, and blue On/Off individually in order to adjust each colour more accurately.

NOTE: This feature is not available when **Picture Mode** is set to **AutoView**.

- 1 In the **Advanced Picture Settings** menu, press ▼ to select **Expert Mode** and press **OK**.
- 2 Press ▲ or ▼ to select either **Red**, **Green** or **Blue** you and press ◀ or ▶ to select **On**. Select **Off** for the other two colours.

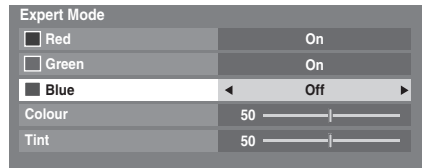

- 3 Press ▼ to select **Colour** or **Tint**, and then press ◀ or ▶ to adjust.

Resetting the advanced picture settings

This feature allows you to reset the current **Advanced Picture Settings** to the default values.

- 1 In the **Advanced Picture Settings** menu, press ▼ to select **Reset**.
- 2 Press **OK**.

Control Visualization

This feature displays the brightness histogram and control curve of each scene.

- 1 In the **PICTURE** menu, press ▼ to select **Control Visualization** and press (OK). The histogram window will appear.

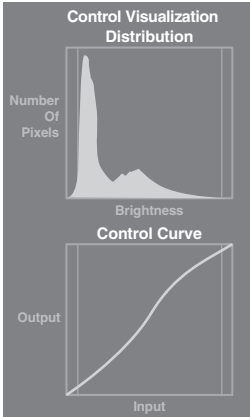

- 2 Press **RETURN** to return to the previous menu.

Automatic Format (Widescreen)

When this television receives a true Widescreen picture and **Auto format is On**, it will automatically be displayed in Widescreen format irrespective of the television's previous setting.

- 1 Press **MENU** and ◀ or ▶ to select the **PREFERENCES** menu.
- 2 Press ▼ to highlight **Auto Format**, then ◀ or ▶ to select **On** or **Off**.

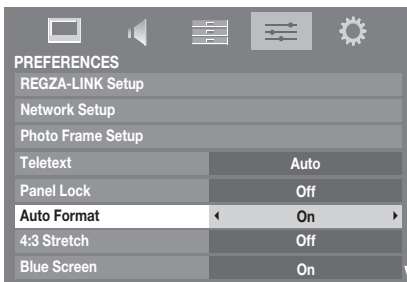

4:3 Stretch

When **4:3 Stretch** is activated, the size switching system changes 4:3 programmes into full screen picture.

- 1 In the **PREFERENCES** menu, press ▼ to highlight **4:3 Stretch**.
- 2 Press ◀ or ▶ to select **On** or **Off**.

Blue Screen

When **Blue Screen** is selected the screen will turn blue and the sound will be muted on analogue channels and external input modes when no signal is received.

- 1 In the **PREFERENCES** menu, press ▼ to highlight **Blue Screen**.
- 2 Press ◀ or ▶ to select **On** or **Off**.

Side panel adjustment

The **Side Panel** feature lightens or darkens the band on each side of the screen when in 4:3 or 14:9 format. This helps prevent image retention of the band and can also make viewing in bright or dark conditions more comfortable.

- 1 In the **PREFERENCES** menu, and press ▼ to select **Side Panel**.
- 2 Press ◀ or ▶ to adjust (1-3).

Picture still

This feature is used to hold a still image on the screen.

Press (P) to hold an image on the screen, press (P) again to cancel.

HDMI Information Display

When the HDMI Information Display feature is On and you are watching a HDMI input source, pressing the (i+) button displays the HDMI signal information banner.

- 1 In the **PREFERENCES** menu, and press ▼ to select **HDMI Information Display**.
- 2 Press ◀ or ▶ to select **On**.

HDMI signal information is as follows:

Resolution, Scan Type, Frame Rate, Aspect, Colour Depth, Colour Space, RGB/YUV and Chroma Format.

Using the Media Player

You can enjoy photos, movies or music contents stored on a USB storage device or SD memory card (for photos only).

Photo Viewer specifications

Data type: JPEG Exif ver2.2

File format: JPEG

Maximum photo size: 9 MB

Maximum number of files: 2000 / folder

Maximum photo resolution: 4096 × 4096 (HW decode),
16384 × 16384 (SW decode)

Movie Viewer specifications

File format: Video: DivX
Audio: MP3

Maximum video resolution: 720 × 480 (30 fps). 720 × 576
(25fps)

Maximum number of files: 500 / folder

Music Player specifications

File format: MP3

Sampling frequency: 16 kHz, 22.05 kHz, 24 kHz, 32 kHz,
44.1 kHz, 48 kHz

Bit rate: from 8 to 320 kbps

Maximum number of files: 500 / folder

PLEASE NOTE

- Gently insert the USB device into the port and do not remove while viewing Media Player.
- USB device: USB Mass Storage Class device (MSC)
- Connectivity is not guaranteed for all devices.
- Connect the USB device to the TV directly.
- Do not use a USB hub.
- You must obtain any required permission from copyright owners to use copyright content. Toshiba cannot and does not grant such permission.

To select the Auto Start function

- 1 Press **MENU** and ◀ or ▶ to select the **APPLICATIONS** menu.
- 2 Press ▼ to select **Media Player**, and then press **OK**.
- 3 Press ▼ or ▲ to select **Auto Start**.
- 4 Press ◀ or ▶ to select **On** or **Off**.
See the **Media Player** menu at right.

NOTE: The Auto Start function does not operate for the LAN port.

To open the Media Player

There are two kinds of methods to open the Media Player.

Automatically open

- 1 Gently insert a supported USB storage device to the USB port or SD memory card into the SD card slot on the side of the TV. A prompt will appear.

NOTE: If you repeatedly insert and remove the USB connector, the prompt may not appear.

- 2 Press ◀ or ▶ to select **Yes**, and then press **OK**. When the **Auto Start** function is **On**, the **Media Player** menu will appear. When you select **No**, nothing happens.

USB device was connected to TV. Do you want to open Media Player?

No Yes

NOTE: The prompt will disappear after about 6 sec.

Manually open

- 1 Press **MENU** and ◀ or ▶ to select the **APPLICATIONS** menu.
- 2 Press ▼ to select **Media Player**, and then press **OK**.
- 3 Press ▼ or ▲ to select **Photo**, **Movie** or **Music** then press **OK**.

Media Player

Photo
Movie
Music
Auto Start On
DivX® VOD

- 4 Press ▼ or ▲ to select the active device if the selection window appears, and then press **OK**.

Media Player

USB1: XXXXXXXXXXXXXXXXXXXXXXXXXXXXXXXX...
USB2: XXXXXXXXXXXXXXXXXXXXXXX
LAN-S: XXXXXXXXXXXXXXXXXXXXXXX
SD Memory Card

The thumbnail view (for Photo) or list of files (for Movie and Music) will appear.

NOTE:

- The viewer will also open even if there are no photo, movie or music files.
- While the Media Player is active, the main menus cannot be displayed.

Viewing photo files

There are three types of view modes.

Multi View

This view allows you to search for photos in a grid format. These pictures are displayed using thumbnail data in each image file.

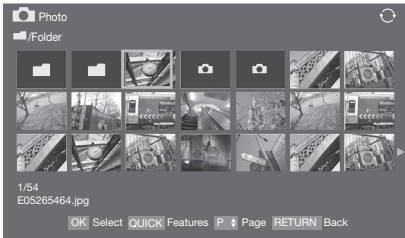

The initial highlighted position will be on the top left thumbnail in the Multi View.

- 1 Press **▲▼◀▶** to move the highlight in one window. If all of the photos will not fit in one screen, when pressing **◀** at the top left thumbnail, the screen will move to the previous page. Conversely, when pressing **▶** at the bottom right thumbnail, the screen will move to the next page.

P▲P▼ buttons can be used to page up/down the photo list when there are more photos than will fit onto one screen. When the **P▲P▼** buttons are pressed, the highlight shall be on the photo at the top left of Previous/Next list.

- 2 When you select a folder, press **OK** to move to the next layer. Press **RETURN** to move back to the previous layer.
- 3 Press **OK** to view the selected photo in Single View mode.

Single View

In this view mode, only files located in the selected directory shall be displayed. This view allows you to change the photo content manually. When moving from Multi View to the Single View, the currently selected photo shall be displayed.

- 1 Press **▶** to view the next photo. Press **◀** to view the previous photo.
- 2 Press **▲** to rotate the image 90° clockwise. Press **▼** to rotate the image 90° counterclockwise.
- 3 Press **i+** to display file status information (file number, photo title, date and time taken, resolution etc.). The information display will time out (after

about 6 seconds) or you can close by pressing **i+** again.

Slideshow

This view allows you to watch a slideshow of the photos. In this mode, only files located in the selected directory will be played.

- 1 To start slideshow, press **OK** in the Single View mode.
- 2 Press **◀/▶** to view the previous/next photo.
- 3 Press **▲** or **▼** to rotate the photo.
- 4 Press **i+** to display file status information. The information display will time out (after about 6 seconds) or you can close by pressing **i+** again.

To set Interval Time and Repeat settings:

- 1 Press **QUICK** to open the **Quick Menu**.
- 2 Press **▲** or **▼** to select either **Interval Time** or **Repeat**.
- 3 Press **◀** or **▶** to adjust the setting and press **OK**.

To close the Photo Viewer

- 1 Press **EXIT**. The television will return to the last viewed channel or external input.

Viewing movie files

You can select movies from a list of available files.

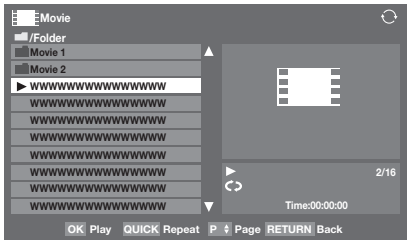

- 1 Press **▲ ▼** to select a file or folder. **P ▲ P ▼** buttons can be used to page up/down the movie list when there are more files than will fit onto one screen.
- 2 When you select a folder, press **OK** to move to the next layer. Press **RETURN** to move back to the previous layer.
- 3 With the desired file selected, press **OK** or **PLAY** (**▶**) to start playback.
- 4 Press **■** to stop playback.

NOTE:

- The Media Player memorizes the location where playback is stopped. The file resumes playback from the location where playback was stopped when you press **PLAY** (**▶**) next time. To start playback from the beginning regardless of the location where playback was stopped, press **■** twice.
- If playback finishes before **■** is pressed, the next file will automatically start to play from the beginning.
- Depending on the file size, it may take some time for playback to begin.

During playback:

- Press **II/III** to pause.
- To resume normal playback, press **PLAY** (**▶**).
- To play in fast reverse or fast forward directions, press **◀◀** or **▶▶** during playback. Each time you press the **◀◀** or **▶▶**, the playback speed will change.
- To locate a specific file, press **◀◀** or **▶▶** repeatedly.

NOTE: If the previous or next file is not compatible, it will be skipped automatically.

- Press **[i+]** to display the file status information (content number, movie title, progress time etc.). The information display will time out (after about 6 seconds) or you can close by pressing **[i+]** again.

NOTE: During playback, you can adjust the **PICTURE**, **Picture Size** and **SOUND** menu functions from the **QUICK** menu.

To select subtitle and audio languages

- Press **SUBTITLE** repeatedly to select your preferred subtitle language.
- Press **AUDIO** repeatedly to select your preferred audio language.

To set the repeat mode

- 1 Press **QUICK** to open the **Quick Menu**.
- 2 Press **◀** or **▶** to select **Off**, **All** or **1**.
- 3 Press **RETURN**.

To close the Movie Viewer

- 1 Press **EXIT**.

To register your TV to a DivX® account

This TV allows you to play back files purchased or rented from DivX® VOD Video-On Demand (VOD) services. When you purchase or rent DivX® VOD files on the internet, you will be asked to enter a registration code.

- 1 In the **APPLICATIONS** menu, press **▼** to highlight **Media Player**, and then press **OK**.
- 2 Press **▲** or **▼** to highlight **DivX® VOD**, and then press **OK**.



- 3 Press **▲** or **▼** to highlight **DivX® VOD Registration**, and then press **OK**.
- 4 The DivX® VOD window will appear and you will see the registration code. For details on registration, please visit the DivX® website at <http://vod.divx.com>.
- 5 Copy the activation file to a memory device and play it on the TV.

To deactivate your device

- 1 In step 3 above, highlight **DivX® VOD Deactivation**, and then press **OK**.
- 2 A confirmation message will appear. Select **Yes**, and then press **OK**.
- 3 The DivX® VOD window will appear and you will see the deactivation code. For details on registration, please visit the DivX® website at <http://vod.divx.com>.

Playing music files

You can listen to music from a list of available files.

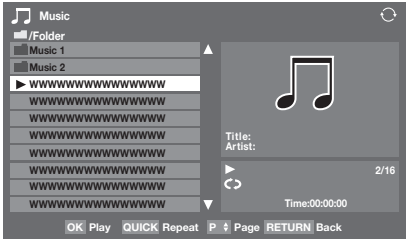

To set the repeat mode:

- 1 Press **QUICK** to open the **Quick Menu**.
- 2 Press **◀** or **▶** to select **Off**, **All** or **1**.
- 3 Press **RETURN**.

To close the Music Player:

- 1 Press **EXIT**.

- 1 Press **▲** **▼** to select a file or folder. **P▲** **P▼** buttons can be used to page up/down the music list when there are more files than will fit onto one screen.
- 2 When you select a folder, press **OK** to move to the next layer. Press **RETURN** to move back to the previous layer.
- 3 With the desired file selected, press **OK** or **PLAY** (**▶**) to start playback.
- 4 Press **■** to stop playback.

NOTE:

- The Media Player memorizes the location where playback is stopped. The file resumes playback from the location where playback was stopped when you press **PLAY** (**▶**) next time. To start playback from the beginning regardless of the location where playback was stopped, press **■** twice.
- If playback finishes before **■** is pressed, the next file will automatically start to play from the beginning.
- Depending on the file size, it may take some time for playback to begin.

During playback:

- Press **||/||▶** to pause.
- To resume normal playback, press **PLAY** (**▶**).
- To play in fast reverse or fast forward directions, press **◀◀** or **▶▶** during playback. Each time you press the **◀◀** or **▶▶**, the playback speed will change.
- To locate a specific file, press **◀◀◀** or **▶▶▶** repeatedly.

NOTE:

- If the previous or next file is not compatible, it will be skipped automatically.
- During playback, you can adjust the **SOUND** menu functions from the **QUICK** menu.

Using a networked server PC

This TV is a DLNA CERTIFIED™ Player. This TV can play digital content stored on a DLNA CERTIFIED product with server function.

To play the files from your PC on the TV, you have to first complete the following:

- Home network connection (page 12)
- ULCS application installation (supplied CD-ROM), if you do not have the DLNA server (page 12)
- IP Address/Subnet Mask setup (page 53)

Photo Viewer specifications

Data type: JPEG Exif ver. 1.x or later, JFIF 1.02

File format: JPEG

Maximum photo size: 6 MB

Maximum number of files: 2000 / folder

Maximum photo resolution: 4096 x 4096 pixels

Movie Viewer specifications

File format: Video: MPEG2(PS) PAL, MPEG2(PS) NTSC, MPEG2(TS)

Audio: LPCM / MPEG1-Layer1 / MPEG1-Layer2 / MPEG2-Layer2 / AC3

Maximum number of files: 1000 / folder

Music Player specifications

File format: MP3, LPCM

Sampling frequency: 32 kHz, 44.1 kHz, 48 kHz

Bit rate: from 32 to 320 kbps

Maximum number of files: 1000 / folder

To open the Media Player

Display the Select Device menu following the section "Manually open" on page 32, select the Server device, and then press **OK**.

To display device information

- 1 While the Photo list, Movie list or Music list is on the screen, press **QUICK** to open the **Quick Menu**.
- 2 Press **▲** or **▼** to highlight **Device Information**, and then press **OK**.

Contents	Functions	Description
Photo	Photo list (Multi view)	See page 33.
	Sorting	
	To sort the folders and files	
	1	Press QUICK to open the Quick Menu from Multi View mode.
	2	Press ▲ or ▼ to select Sort .
	3	Press ◀ or ▶ to select File Name , New or Old to set the sorting rule.
	File Name--File sorting rules:	
	1	Unicode priority
	2	{0, 1, ..., 9}, capital alphabet (A, B, ..., Z), small alphabet (a, b, ..., z), Chinese
	3	Increasing order
	New-- From new to old according to the date and time when the picture was taken.	
	Old-- From old to new according to the date and time when the picture was taken.	
	Device Information display	See page 36.
	Single view mode	See page 33.
	Slide Show mode	See page 33.
	Skip to previous/next photo	See page 33.
	Rotation	See page 33.
	Slideshow Repeat play	See page 33.
	Slideshow Interval Time selection	See page 33.
	Picture Size selection	See page 25.

Contents	Functions	Description
Movie	Movie list (title list)	See page 34.
	Sorting	
	To sort the folders and files	
	1	Press QUICK to open the Quick Menu in the movie list mode.
	2	Press ▲ or ▼ to select Sort .
	3	Press ◀ or ▶ to select File name, New or Old to set the sorting rule.
	Device Information display	See page 36.
	Playback	See page 34.
	NOTE: When a file is highlighted, playback will begin automatically in the preview window. Press (OK) or PLAY (▶) to start full screen playback.	
	Pause	See page 34.
	Stop	See page 35.
	NOTE: If STOP is pressed in full screen playback, you will go back to the preview window and playback will start again from the beginning of the file. If a file plays to the end in full screen mode, you will also go back to the preview window and the file will play from the beginning.	
	Rewind / Fast Forward	See page 34.
	Skip to previous/next video	See page 34.
	Repeat play	See page 34.
	Subtitle / Audio Language selection	See page 34.
Picture Size selection	See page 25.	
PICTURE Settings	See page 27.	
SOUND Settings	See page 22.	

Contents	Functions	Description
Music	Music list (title list)	See page 35.
	Sorting	
	To sort the folders and files	
	1	Press QUICK to open the Quick Menu .
	2	Press ▲ or ▼ to select Sort .
	3	Press ◀ or ▶ to select File name, New or Old to set the sorting rule.
	Device Information display	See page 36.
	Playback	See page 35.
	Resume playback	See page 35.
	Pause	See page 35.
	Stop	See page 35.
	Skip	See page 35.
	Rewind / Fast Forward	See page 35.
Repeat play	See page 35.	
SOUND Settings	See page 22.	

NOTE: Sorting, Rewind, Fast Forward, Time bar display, Total Time display may not be available in all cases.

Using the Photo Frame feature

You can use the TV screen as a digital picture frame. One image (pre-installed or user-installed) can be displayed. Date and time info can also be superimposed, if desired.

You can overwrite the photo file with a file on the USB storage device or SD card.

To open Photo Frame

Open from Menu

- 1 Press **MENU** and ◀ or ▶ to select the **PREFERENCES** menu.
- 2 Press ▼ to select **Photo Frame Setup**, and then press **OK**.

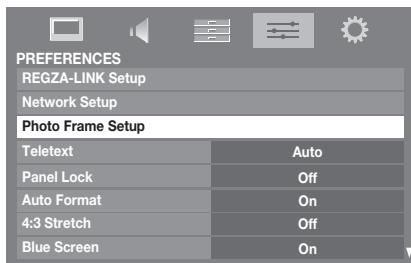

The preview screen will appear.

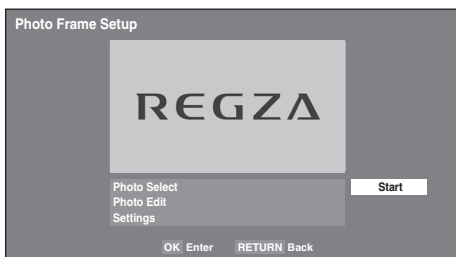

- 3 Press ▶ to select **Start**, and then press **OK** to open **Photo Frame**.



To open from the Quick Menu

- 1 Press **QUICK** to open the **Quick Menu**.
- 2 Press ▲ or ▼ to select **Photo Frame**, and then press **OK** to open **Photo Frame**.

To close the Photo Frame:

- 1 Press **EXIT**.

Setting the features

In the preview screen, you can set various settings for Photo Frame.

Photo Select

- 1 In the **Photo Frame Setup** menu, press ▲ or ▼ to select **Photo Select**, and then press **OK**.

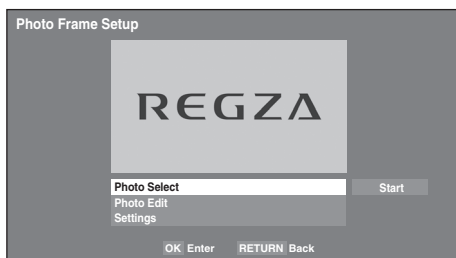

- 2 If the device selection screen appears, press ▲ or ▼ to select the appropriate device, and then press **OK**.

- 3** Press ▲▼◀▶ to select the photo you want to copy from the USB storage device or SD card to the TV's flash memory, and then press **OK**.

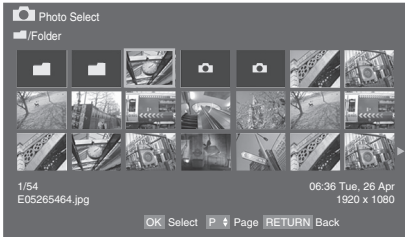
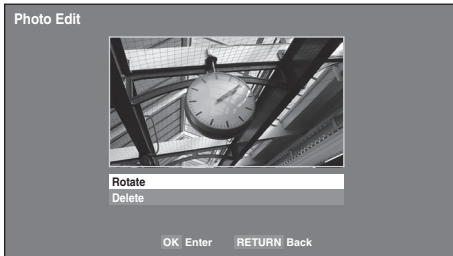

Photo Edit

- 1** Press ▲ or ▼ to select **Photo Edit**, and then press **OK**.
- 2** Press ▲ or ▼ to select **Rotate** or **Delete**.



- 3** Set the following items as required.
- **Rotate** — Press **OK** to rotate the image 90° clockwise.
 - **Delete** — Press ◀ or ▶ to select **YES**, and then press **OK**.
- 4** Press **RETURN**.

Settings

- 1** Press ▲ or ▼ to select **Settings**, and then press **OK**.

- 2** Press ▲ or ▼ to select **Clock**, **Position** or **Auto Power Off**.

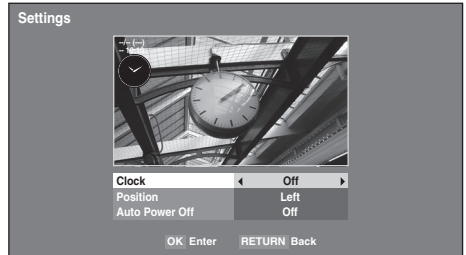

- 3** Set the following items as required.
- **Clock** — Press ◀ or ▶ to select **Off**, **Digital Clock**, **Analogue Clock** or **Analogue + Digital**.
 - **Position** — Press ◀ or ▶ to select **Left** or **Right**.
 - **Auto Power Off** — Press ◀ or ▶ to select **Off**, **00:30**, **01:00**, **02:00**, **04:00**, **06:00** or **12:00**.
- If the Photo Frame window is left open, the TV will automatically turn off after the set length of time (maximum 12 hours).

- 4** Press **RETURN**.

- 5** Select **Start**, and then press **OK**.



NOTE:

- The clock display will only appear when time from a digital broadcast is available.
- The Photo and Settings items are moved by 4 dots every 5 minutes to prohibit screen burn-in.
- The pre-installed photo file is stored in the TV's flash memory before shipment.
- Picture Size selection (Normal/ Dot by Dot) is available by pressing the QUICK button.

Other features

Panel Lock

Panel Lock disables the buttons on the television. All buttons on the remote control can still be used.

- 1 From the **PREFERENCES** menu, select **Panel Lock** and choose **On** or **Off** using ◀ or ▶.

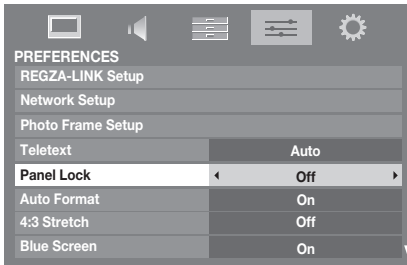

When **Panel Lock** is **On**, a reminder will appear when the buttons on the television are pressed. **If the standby button is pressed, the television will switch off and can only be brought out of standby by using the remote control.**

TOSHIBA Illumination

You can set the illumination mode of the TOSHIBA logo located on the front panel to **On** or **Off**.

- 1 In the **PREFERENCES** menu, press ▼ to select **TOSHIBA Illumination**.
- 2 Press ◀ or ▶ to select either **On** or **Off**.

The timers

Programme Timers – digital only

This feature will set the television to go to a specific channel at a certain time. It can be used to view a particular programme, or by setting the mode to daily or weekly, can be used to view a series of programmes.

- 1 Press **MENU** and ◀ or ▶ to select the **APPLICATIONS** menu.

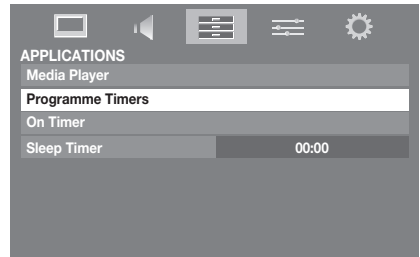

- 2 Press ▼ to select **Programme Timers**, and then press (OK).
- 3 Press ▼ if necessary to select an open timer position, then press (OK). The **Edit Timer** menu will now appear on screen.
- 4 Press ▲ and ▼ to go through the list adding the details of the programme by using the number buttons and ◀ and ▶ to make selections.

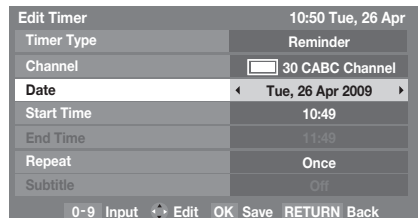

- 5 When all of the details have been entered, press (OK) to save the timer.

The **ORANGE/RED** programme timer indicator on the front of the television will be lit (see page 58 for details).

PLEASE NOTE: When a timed programme is about to start, an information screen will appear offering the option of watching or cancelling the programme. The menus and other channels will not be available during the timed programme unless the programme timer is cancelled. The programme timer you set is not performed when the TV is turned off with the **POWER** switch.

On Timer

The feature allows you to set the television to turn on automatically to a preset channel at a certain time of day or after a certain length of time. When **On Timer** is set to **On**, the green **On Timer** indicator on the front of the television is lit.

- 1 In the **APPLICATIONS** menu, press ▼ to select **On Timer** and press **OK**.
- 2 Press ▲ or ▼ to select **Enable On Timer**, and then press ◀ or ▶ to select **On**.

On Timer	
Enable On Timer	◀ On ▶
Enable DTV Clock	On
Power On Time	00:00
Repeat	Once
Input	DTV
Channel	12 ABC
Volume	20
Time until Power On	00:00

- 3 Press ▼ to select **Enable DTV Clock**, and then press ◀ or ▶ to select **On** or **Off**.
- 4 Press ▲ or ▼ to go through the list adding the details of the **On Timer** by using the number buttons and ◀ and ▶ to make selections.

Power On Time (only for DTV Clock On mode): Set the time you prefer with the number buttons.

Repeat (only for DTV Clock On mode): Select the desired **On Timer** operation (**Once**, **Everyday**, **Mon-Fri**, **Mon-Sat**, **Sat-Sun**).

Input: Select a video input source (ATV, DTV, EXT 1, EXT 2, EXT 3, HDMI 1, HDMI 2, HDMI 3, HDMI 4 or PC).

Channel: Set the channel that will be tuned when the television turns on.

NOTE: When an external input is selected in the **Input** field, a channel cannot be selected.

Volume: Set the volume that will be applied when the television turns on.

Time until Power On (only for DTV Clock Off mode): Set the amount of time from now until the TV turns on using the number buttons (maximum of 12 hours and 50 minutes).

To cancel the On Timer

- 1 In the **On Timer** menu, select **Enable On Timer**
- 2 Press ◀ or ▶ to select **Off**.

Sleep Timer

The television can be set to turn itself **Off** after a certain length of time.

- 1 In the **APPLICATIONS** menu, press ▼ to select **Sleep Timer**. Use the number buttons to set the desired time. For example, to switch the television off in one and a half hours enter 01:30, or press ▶/◀ to increase/decrease in steps of 10 minutes.
- 2 Press **EXIT** to finish.
- 3 To cancel the **Sleep Timer**, enter all zeros for the above setting.

Digital on-screen information and Programme Guide

When viewing in **digital** mode, the on-screen information and programme guide provide access to programme details for all available channels.

Information

- 1 Press **i+**, the information screen will appear giving details of the channel and programme currently being viewed.

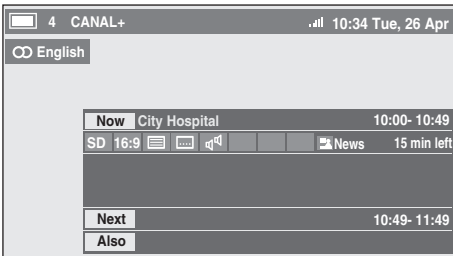

- 2 Press **▲** or **▼** to select the "Now", "Next" or "Also" information guide.

- 3 To record the next scheduled programme, select "Next" and press **OK**. The **Edit Timer** screen will appear.

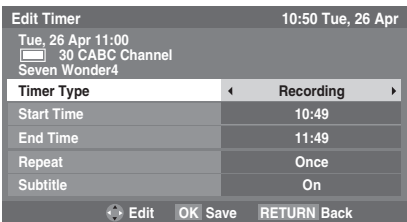

- 4 The details of the programme will already have been added to the timer. Press **OK** to save.

To indicate that a Recording Timer has been set, a clock icon will be displayed in the **Next** and **Also** fields of the information screen. A check mark will appear if the timer is a Reminder Timer.

- 5 Press **▼** to select **Also**. Details of programmes that have started on other channels will be provided. Use **◀** or **▶** to change the display contents.

On-screen Information icons

	Icon	Description
Service info		Service type (TV, Radio, TEXT)
		Skip
Audio info		Mono
		Stereo
		Dual mono
		Multichannel
		Dolby Digital
		Dolby Digital+
Audio/Subtitle info		For Hard of Hearing
Event info		Video format (HD, SD)
		Video Aspect
		Teletext
		Subtitle (Single, Multi)
		Multi-audio track
		Parental rating
		Encrypted
Timer info		Recording
		Reminder

Guide

- 1 Select the on-screen guide by pressing **GUIDE**, the guide screen will appear highlighting details of the channel and programme currently being viewed. This may take a few moments to appear.

Thu6	10:50 Tue, 6 Apr				
TV	← 18:00	18:30	19:00	19:30	20:00 →
6 M6	LES SIMPSON...	ES SIM...	TOP MODEL		
9 W9	SUMMERLAND	SUMMERLAND	LES SIM...		
11 NT1	Nicky La...	Street fight...	Dragon B...	Dragon B...	K 2000
31 PARIS PREMIERE	MA SORCIE...	HAPPY DAYS	HAPPY DAYS		
34 AB1	Evamag	21 jump street	Jerry Springer Show	City guys	L...
800 FlowerGd 6Mbs					
801 FlowerGd 4Mbs					
802 FlowerGd 2Mbs					
804 Codec 4:3					
806 ITV1					
807 ITV3					
808 ITV2					
809 ITV4					

You can switch the time scale to 1.25 or 2.5 hours by pressing the **GREEN** button.

NOTE: Channels are displayed in groups by service type (TV, Radio, Text). Pressing the **ATV/DTV** button will switch the service type.

- 2 Press **◀** or **▶** for information on other programmes scheduled for the channel selected. To highlight the first programme in the genre grid, press the **RED** button.
- 3 For details of other programmes currently available, press **▲** and **▼** to scroll up and down the channel list. As channels are selected, details of the programme currently being broadcast will appear. Press **◀** or **▶** to view information for future programmes.
- 4 For information on a highlighted programme, press **i+**.
- 5 To set the timer for that programme, press the **BLUE** button to bring up the **Programme Timers** menu.

NOTE: In order for the recording operation to work properly, the media recorder must be set to the same time as the TV. Regarding the process for recording, please refer to the owner's manual of the recording equipment.
- 6 Press **Pv** to advance to the next page, or press **P^** to go back to the previous page.

Genre selection/searching

From the guide screen, you can use the genre selection and search features.

- 1 Press the **QUICK** button from the guide screen.
- 2 Press **▼** or **▲** to highlight **Genre Colour** in the **Quick Menu**, then press **OK**.

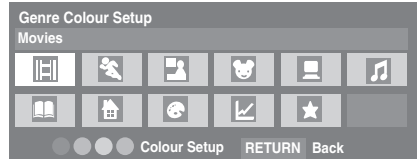

- 3 With the focus on a particular genre, press the desired colour key to assign. Four colours will be available to set. Press **RETURN** to go back to the guide screen.
- 4 Press the **YELLOW** button to access the **Genre Search** screen.

Genre Search		10:50 Tue, 6 Apr
Movies		
34 AB1	Hard Rain	Wed,27 Apr 0:15- 1:45
31 PARIS PREMIERE	Red Corner	Wed,27 Apr 22:15- 23:55
11 NT1	The Lawnmower Man	Thu,28 Apr 1:20- 3:00
9 W9	A Vow to Kill	Fri,29 Apr 1:30- 3:00
34 AB1	Parenthood	Sat,30 Apr 0:45- 2:40
11 NT1	Body and Soul	Sat,30 Apr 1:15- 3:00
31 PARIS PREMIERE	The Nun's Story	Sat,30 Apr 15:00- 17:30
9 W9	Red Corner	Sat,30 Apr 23:20- 1:15
11 NT1	The Real Blonde	Sun,1 May 0:40- 2:00
31 PARIS PREMIERE	Critters	Sun,1 May 0:40- 2:20
11 NT1	Indiana Jones and the Temple of Doom	Sun,1 May 21:10- 23:20
11 NT1	The jackal	Sun,1 May 23:20- 1:15
34 AB	Coup De Ville	Mon,1 May 1:10- 3:00

- 5 Press **◀** or **▶** to select the genre. Programmes listed will change for the new genre. Press **▲** or **▼** to highlight a particular programme.
- 6 When a current programme is selected, pressing **OK** will tune to that programme. When a future programme is selected, pressing **OK** will open the **Edit Timer** menu.
- 7 For information on a highlighted programme press **i+**.
- 8 To exit the **Genre Search** and go back to the guide screen, press the **YELLOW** button.

Digital settings – parental control

In order to prevent viewing of unsuitable films and programmes, channels and menus can be locked in digital mode. These can then only be accessed with a security code PIN.

Setting the PIN

- 1 Press **MENU** and **▶** to select the **SETUP** menu.
- 2 Use **▼** to select **DTV Settings**, and then press **OK**.

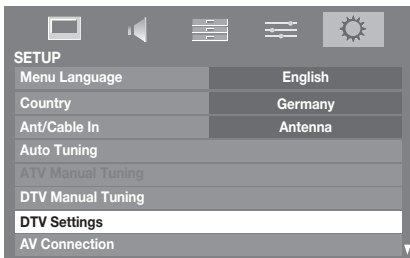

- 3 Press **▼** to highlight **PIN Setting**, and then press **OK**.

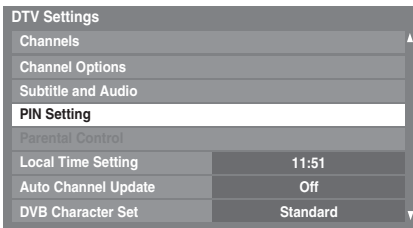

- 4 Using the number buttons enter a four digit number. Once entered you will be prompted to confirm by entering again.



The PIN number is now set.

If the PIN code has been set, when **Auto Tuning** and **Reset TV** are executed, entering the PIN will be necessary.

Parental Setup

The *Parental Control* feature allows you to block programmes according to their rating levels. If a PIN has been set, you will need to enter it before adjusting the level.

- 1 In the **DTV Settings** menu, press **▼** to select **Parental Control**, and then press **OK**.
- 2 Use **◀** or **▶** to choose an option (**None** or an age setting (4-17)).



To view blocked programmes, enter the PIN. To reactivate the Parental Control, turn the TV off and then on again.

Digital settings – Channel Options

Channel List

1 Press the **LIST** button to open the **Channel List**.

2 The **Channel List** will appear.

Press **▲** or **▼** to highlight a channel and press **OK** to watch.



Skipping channels

*This feature allows you to set channels that will be skipped when **P▼** or **P▲** are used to tune.*

1 From the **DTV Settings** menu, press **▼** to select **Channel Options** and press **OK**.

2 Press **▲** or **▼** to select a channel position to be skipped. Press **OK** to set the one desired. A tick will appear in the box.



3 Press **EXIT**.

NOTE: Skipped channels cannot be selected by **P▼** or **P▲** but can still be accessed by direct number entry (when tuned the **↻** icon will be displayed in the banner to indicate as a skipped channel).

Locking channels

Locking Channels stops the viewing of **digital** channels. They can only be accessed by entering the **PIN**.

- 1** From the **DTV Settings** menu, press **▼** to select **Channel Options** and press **OK**.
- 2** Press **▶** to select the Locked Channel list.
- 3** Press **▲** or **▼** to select a channel position to be locked. Press **OK** to set the lock. A tick will appear in the box.

If a **PIN** has already been set, **PIN** entry will be required to set the locked channels.

- 4** Press **EXIT**.
- 5** From this point on, when any of the channels in the **Locked Channel** list are selected, the **PIN** must be entered before they can be accessed.

Digital settings – other settings

Subtitles

In digital mode, this feature will show subtitles on the screen in the selected language provided they are being broadcast.

- 1 In the **DTV Settings** menu, press ▼ to select **Subtitle and Audio** and press (OK).
- 2 Press ▼ to select **Subtitle Type** and use ◀ or ▶ to select **Normal** or **For Hard of Hearing**.

Subtitle and Audio	
Subtitle Type	◀ Normal ▶
Primary Subtitle Language	English
Secondary Subtitle Language	French
Audio Type	Normal
Primary Audio Language	English
Secondary Audio Language	French

- 3 Press ▼ to select **Primary Subtitle Language** or **Secondary Subtitle Language** and use ◀ or ▶ to select an option.

The **SUBTITLE** button can be used to select subtitle ON or OFF, and to select the subtitle language if more than one subtitle is available.

Audio languages

This feature allows a programme or film to be viewed with a choice of soundtrack language, provided multiple language tracks are being broadcast.

- 1 In the **Subtitle and Audio** menu, press ▼ to select **Audio Type** and use ◀ or ▶ to select **Normal** or **For Hard of Hearing**.
- 2 Press ▼ to select **Primary Audio Language** or **Secondary Audio Language** and use ◀ or ▶ to select an option.

If more than one soundtrack is available, use the  button to select between them.

Common Interface

The *Common Interface Slot*, situated on the side of the television, enables the insertion of a CAM (Conditional Access Module) and card. These are purchased from a service provider and allow additional subscription broadcasts to be viewed. For information, see a service provider.

- 1 Insert the CAM and card into the Common Interface Slot, following the instructions provided with the CAM. A box will appear on screen to confirm that the CAM has been inserted.
- 2 In the **DTV Settings** menu, press ▲ or ▼ to select **Common Interface** and press (OK).
- 3 Details of the CAM should now be available.

Software Upgrade and Licenses

Auto Upgrade

When **Auto Upgrade** is set to **On** (default setting), the television will automatically upgrade while in standby if new software is available.

- 1 From the **SETUP** menu, press **▲** or **▼** to select **Software Upgrade** and press **OK**.
- 2 Press **▼** to select **Auto Upgrade**.
- 3 Use **◀** or **▶** to select **On** or **Off**.

Searching for New Software

If preferred, software upgrades can be searched for manually using **Search for New Software**.

- 1 In the **Software Upgrade** menu, press **▲** or **▼** to select **Search for New Software**.
- 2 Press **OK**. The television will automatically start searching for a software upgrade, the progress bar will move along the line.

SEARCHING FOR NEW SOFTWARE

Searching for a new software upgrade for this TV.

Searching 

If an upgrade is found, the television will automatically start downloading. If not, a screen will appear stating that an upgrade is unavailable.

Software Licenses

The Licenses for the software used in this television are available for viewing.

- 1 In the **SETUP** menu, press **▲** or **▼** to select **Software Licences** and press **OK**.

A screen will appear displaying all the licensing information required for the televisions software.

System Information and Reset TV

System Information

This feature can be used to check the version of software currently installed. When in DTV mode, it includes additional diagnostic information such as signal strength, signal quality, centre frequency, modulation, etc.

- 1 From the **SETUP** menu, press **▲** or **▼** to select **System Information**.
- 2 Press **OK** to display the **System Information**.

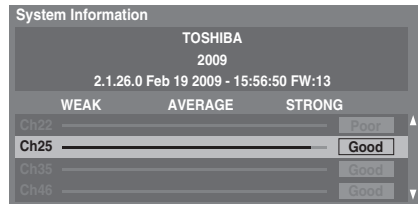

- 3 For information about the signal quality of a particular multiplex, press **▲** or **▼** to select that multiplex.
- 4 Press **OK** for a screen showing detailed technical information about the selected multiplex.

Automatic Power Down

The TV will automatically turn itself off (standby) after approximately 4 hours, if you don't touch the control buttons on the remote control or on the TV control panel.

- 1 In the **SETUP** menu, press **▼** until **Automatic Power Down** is highlighted.
- 2 Use **◀** or **▶** to select **On**.

Reset TV

Selecting **Reset TV** will reset all TV settings, including saved channels, to their original factory values.

- 1 In the **SETUP** menu, press **▼** until **Reset TV** is highlighted.
- 2 Press **OK** to select. A screen will appear warning that all settings will be lost. Press **OK** to continue.

When the set powers back on, the **Quick Setup** screen will appear. Press **OK** to advance the setup and perform an auto tune. (See 'Quick Setup' section on page 14.)

PC Settings

Horizontal and Vertical Position

Connect the PC (as shown in the 'Connecting a PC' section) and ensure that a picture is showing on the television screen. The picture position may now be adjusted to suit personal preference.

- 1 Press  to select **PC**, and then select **PC Settings** from the **SETUP** menu.

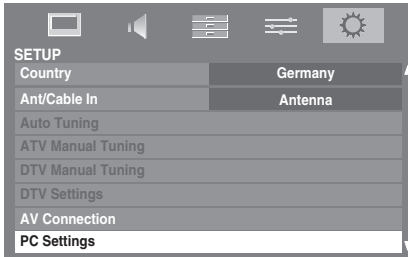



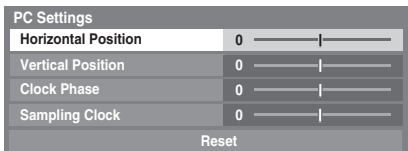

- 2 Press . Press  and  to select an option, then  or  to adjust the settings.







Clock Phase

The **Clock Phase** matches the PC signal with the LCD display. Adjusting this can clear horizontal stripes and picture blur.

- 1 In the **SETUP** menu, press  until **PC Settings** is highlighted.
- 2 Press  to select, and then  to highlight **Clock Phase**.
- 3 Use  or  to adjust until the picture clears.





Sampling Clock

Adjusting the **Sampling Clock** alters the number of pulses per scan, this will clear vertical lines on the screen.

- 1 In the **SETUP** menu, press  until **PC Settings** is highlighted.
- 2 Press  to select, and then  to highlight **Sampling Clock**.
- 3 Use  or  to adjust until the picture clears.

Reset

Use **Reset** to return all items to the original factory settings.

- 1 In the **SETUP** menu, press  until **PC Settings** is highlighted.
- 2 Press  to select, and then  to highlight **Reset**.
- 3 Press .

NOTE: When a PC is connected using HDMI, none of these functions will be available.

The screen is disrupted momentarily when adjusting PC Settings. This is not a sign of malfunction. The default settings and adjustment ranges may vary depending on the input signal format.

Input selection and AV connections

See page 8 for a detailed image showing recommended connections.

Most media recorders and decoders send a signal through the SCART lead to switch the television to the correct *Input* socket.

Alternatively, press the external source selection button  until the picture from connected equipment is shown.

This button must be used to view equipment connected using the COMPONENT VIDEO INPUT (**EXT 3C**).

An **S** in the display e.g.  **2S** (**EXT 2S**), indicates the input is set for an S-Video signal.

Input selection

Use the *Input Selection* window if the television does not switch over automatically.

- 1 By pressing  on the remote control or TV, a list will appear on screen showing all inputs and external equipment.

Pressing  on the remote control

Inputs
TV
 1
 2
 3C
HDMI 1
HDMI 2
HDMI 3
HDMI 4
PC

Pressing  on the TV right side panel

Inputs
DTV TV
DTV RADIO *
DTV TEXT *
 1
 2
 3C
HDMI 1
HDMI 2
HDMI 3
HDMI 4
PC
ATV

* If radio or text channels are currently available for DTV.

HDMI™ displays equipment connected to *Input HDMI* on the back or side of the television.



PC displays a computer connected to *Input RGB/PC* on the back of the television.

External input skip

This feature is designed to make input selection more convenient.

- 1 Press  to select the external input to be skipped (e.g. HDMI 1).

- 2 In the **SETUP** menu, press  to select **Manual Settings** and press .

- 3 Press  or  to set **Skip** on and press .

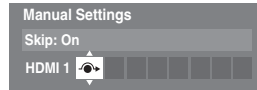





- 4 Press **EXIT**.

The input set to Skip is greyed out in the *Input Selection* window and is skipped over when you press  on the remote control.

Input signal selection

This specifies the type of signal going into **SCART 2 (EXT 2)** on the back of the television. Please refer to the manufacturer's instructions for the connected equipment.



- 1 In the **SETUP** menu, press  until **AV Connection** is highlighted, and then press .
- 2 With  or  select either **AV** or **S-VIDEO** as the required *input* for **EXT 2**.

AV Connection	
PC/HDMI 1 Audio	PC
HDMI 1 Audio	Digital
HDMI Settings	
EXT 2 Input	AV
Woofer	Internal
Digital Audio Output	Auto

If video colour is absent, try the other setting.

Woofer setting

When an active Super Woofer is connected to the Woofer out connection on the back of the television, set the Woofer setting to *External*.

- 1 In the **AV Connection** menu, press  to highlight **Woofer**.
- 2 Press  or  to select **External**.

PC Audio

In order to receive sound from a connected PC, plug the audio cable into the back of the television (as shown in the 'Connecting a computer' section), and then use the **PC/HDMI 1 Audio** setting.

- 1 In the **SETUP** menu, press ▼ until **AV Connection** is highlighted, and then press **OK**.
- 2 Highlight **PC/HDMI 1 Audio**, and then use ► to select the **PC** option.

NOTE: Selecting the **PC** option will force HDMI 1 Audio to Digital mode.

HDMI 1 Audio

If the connected HDMI source does not support digital audio, plug the audio cable into **PC/HDMI 1 (AUDIO)** on the back of the television (as shown in the 'Connecting an HDMI™ or DVI device to the HDMI input' section), then use the **HDMI 1 Audio** setting.

- 1 In the **AV Connection** menu, press ▼ to highlight **PC/HDMI 1 Audio** and using ► select **HDMI 1**.
- 2 Then highlight **HDMI 1 Audio**, and using ◀ or ▶ select **Auto** or **Analogue**.

AV Connection	
PC/HDMI 1 Audio	HDMI 1
HDMI 1 Audio	◀ Auto ▶
HDMI Settings	
EXT 2 Input	AV
Woofers	Internal
Digital Audio Output	Auto

If the sound is absent, try selecting a different setting.

NOTE: HDMI 1 supports digital and analogue sound, HDMI 2, HDMI 3 and HDMI 4 are digital sound only.

Certain DVD disk formats may not output from this TV (32/44.1/48kHz and 16/20/24 bits are acceptable).

HDMI Settings

Some early HDMI equipment may not work properly with your HDMI TV. Please try setting the **Lip Sync** and **INSTAPORT™** options to **Off**. Adjusting these settings should allow your early HDMI source to operate properly with your television.

- 1 In the **SETUP** menu, press ▼ until **AV Connection** is highlighted, then press **OK**.
- 2 Press ▼ to highlight **HDMI Settings** and press **OK**.

NOTE: **HDMI Settings** is grayed out on non-HDMI inputs.

- 3 Press ▲ or ▼ to select an item, and then press ◀ or ▶ to select a setting.

HDMI Settings	
Lip Sync	◀ On ▶
INSTAPORT™	On
RGB Range	Auto

• Lip Sync: On

This option activates an audio/video display timing adjustment function that allows HDMI source devices to accurately perform synchronization automatically.

• INSTAPORT™: On

This feature reduces the lag time when switching HDMI sources.

• RGB Range: Auto

This feature adjusts RGB full range signal automatically. When **Limit** is selected, RGB signal is output in the range from 16 to 235. When **Full** is selected, RGB signal is output in the range from 0 to 255.

NOTE:

- If your HDMI connection is capable of 1080p and/or your television is capable of refresh rates greater than 50Hz or supports Deep Colour, you will need a Category 2 cable. Conventional HDMI/DVI cables may not work properly with this mode.
- All of the above HDMI settings need proper HDMI source devices. If the HDMI source products do not support these features, the television may not work properly by activating these features.

Digital Audio Output

When connecting a surround sound amplifier to the digital audio output (Sony/Philips Digital Interface Format [S/PDIF]), the following options can be selected.

PCM: this mode outputs PCM format to the digital audio output socket.

Auto: this mode outputs Dolby Digital (if available) or PCM to the digital audio output socket.

Dolby Digital → Dolby Digital
 Dolby Digital Plus → Dolby Digital
 MPEG → PCM
 HE-AAC → Dolby Digital

- 1 In the **AV Connection** menu, press ▼ to select **Digital Audio Output**.

- 2 Use ◀ or ▶ to select **PCM** or **Auto**.

HDMI, the HDMI logo, and High-Definition Multimedia Interface are trademarks or registered trademarks of HDMI Licensing, LLC.

INSTAPORT™ and INSTAPORT logo are trademarks of Silicon Image, Inc. in the United States and other countries.

Using REGZA-LINK

This is a new feature that uses CEC technology and allows you to control Toshiba REGZA-LINK compatible devices from the television remote control via HDMI connection (page 10).

When the **Enable REGZA-LINK** item in the **REGZA-LINK Setup** menu is set to **On**, individual functions also set to **On** will be activated.

Enable REGZA-LINK

- 1 Press **MENU** and ◀ or ▶ to select the **PREFERENCES** menu.
- 2 Press ▼ to select **REGZA-LINK Setup**, and then press (OK).
- 3 Press ▼ to highlight **Enable REGZA-LINK**, and then ◀ or ▶ to select **On**.

REGZA-LINK Setup	
Enable REGZA-LINK	◀ On ▶
TV Auto Power On	On
Auto Standby	On
Amplifier Control	On
Speaker Preference	TV Speakers

NOTE: If you set **Enable REGZA-LINK** to **Off**, all other items will be grayed out.

TV Auto Power On

The **TV Auto Power On** setting allows the television to be automatically switched on if a REGZA-LINK device is turned on.

- 1 In the **REGZA-LINK Setup** menu, press ▼ to highlight **TV Auto Power On**.
- 2 Press ◀ or ▶ to select **On** or **Off**.

Auto Standby

When **Auto Standby** is enabled, the television, when switched off, will automatically switch off (standby mode) all connected REGZA-LINK equipment.

- 1 In the **REGZA-LINK Setup** menu, press ▼ to highlight **Auto Standby**.
- 2 Press ◀ or ▶ to select **On** or **Off**.

Amplifier Control

When **Amplifier Control** is set to **On**, it allows the “**Speaker Preference**” feature to become available.

- 1 In the **REGZA-LINK Setup** menu, press ▼ to highlight **Amplifier Control**.
- 2 Press ◀ or ▶ to select **On** or **Off**.

Speaker Preference

This feature allows the audio output preference to be set to the TV speakers or AV amplifier speakers. The AV Amplifier option lets the television’s remote control adjust or mute the volume of the audio.

- 1 In the **REGZA-LINK Setup** menu, press ▼ to highlight **Speaker Preference**.
- 2 Press ◀ or ▶ to select **TV Speakers** or **Amplifier**.

REGZA-LINK input source selection

If a REGZA-LINK device with HDMI switching capability (e.g. AV amplifier) is connected to the HDMI input, you can select another REGZA-LINK device that is connected to the master HDMI device on the input source list.

- 1 Press ⏻ and a list will appear on screen showing available input sources.
- 2 Press ▼ to select the desired input source with REGZA-LINK icon.
- 3 Press ▶ and a second selection screen will appear showing all connected REGZA-LINK equipment.

Inputs	
TV	
↻ 1	
↻ 2	
↻ 3C	
HDMI 1	
HDMI 2	
HDMI 3	REGZA-LINK
HDMI 4	
PC	

◀ 1 DVD	
2	VCR/DVR
3	CBL/SAT
4	GAME/TV
5	AUX

- 4 Press ▲ or ▼ to select the desired input source, and then press (OK).

NOTE:

- These functions depend on the device connected.
- If you select the REGZA-LINK input source from the popup window, some REGZA-LINK devices may automatically turn on.
- When the television is switched on it will take a few minutes for the REGZA-LINK icon to appear in the list. When an HDMI cable is removed it will take a few minutes for the icon to disappear.
- If the HDMI cable from connected equipment is changed, **Enable REGZA-LINK** in the REGZA-LINK Setup menu may need to be reset to **On**.
- If you change the HDMI lead to a connected device or change an HDMI device setting, reset the **Enable REGZA-LINK** item on the REGZA-LINK Setup menu from **Off** to **On**.

REGZA-LINK playback device control

With the REGZA-LINK mode on your television's remote control, you can control the connected REGZA-LINK playback device you are watching.

To control the REGZA-LINK input source first select the equipment by REGZA-LINK input source selection, then switch the mode on the remote control to **REGZA-LINK** and press a button.



See page 6 for details on available remote control key functions.

NOTE: The available functions depend on the equipment connected. All of the remote control keys may not be available. Please refer to the operation manual for each piece of equipment connected.

REGZA-LINK one touch play

When connected equipment is switched on, REGZA-LINK will automatically detect the television through the input selection. If the television is in standby it will be switched on automatically.

These functions can be enabled or disabled from the REGZA-LINK Setup (see page 51).

NOTE:

- Even if the equipment is showing a menu, the television may automatically show the input source.
- This feature depends on the connected equipment and television state.

REGZA-LINK system standby

If the television is turned off (standby mode), the television will send a message to turn off (standby mode) all of the REGZA-LINK devices connected to the television.

These functions can be enabled or disabled from the REGZA-LINK Setup (see page 51).

NOTE: This feature depends on the connected equipment and television state.

REGZA-LINK system audio control

With your television's remote control, you can adjust or mute the sound volume of the speakers connected to the television via an AV amplifier. First, set the remote control mode switch to REGZA-LINK.

- 1 Set the **Speaker Preference to Amplifier** in the **REGZA-LINK Setup** menu.
- 2 Confirm that a connected REGZA-LINK device (such as DVD player, etc) is selected for the AV amplifier input source.

NOTE:

- These functions depend on the device connected.
- When you turn on the AV amplifier, change its input source, or adjust the sound volume, the sound will be output from the AV amplifier's speakers even if **TV Speakers** has been selected. Turn the television off and on again to output the sound from the TV Speakers.
- This feature may not work if the AV amplifier is operated.

REGZA-LINK PC link

This feature automatically adjusts the suitable widescreen formats and picture preferences when connected to a REGZA-LINK PC.

NOTE: This feature depends on the connected equipment state.

Setting up the network address for the LAN port

For information on connecting a home network, see page 12.

- 1 First, try automatically setting up the network address (below).
- 2 If the Auto Setup is not successful, you can either retry the Auto Setup or try manually setting up the network address.

NOTE:

- If you used an Ethernet crossover cable to connect your PC directly to the TV, you may not be able to use the automatic setup, and have to manually set up the network address.
- If you used a hub or switch to connect the TV to your home network, you may not be able to use the automatic setup, and have to manually set up the network address.
- If you used a router with built-in DHCP functionality, use the automatic setup. Manual setup may not work.

Auto Setup

- 1 Press **MENU** and ◀ or ▶ to select the **PREFERENCES** menu.
- 2 Press ▲ or ▼ to highlight **Network Setup** then press **OK**.
- 3 Press ▼ to highlight **Auto Setup**, and then press ◀ or ▶ to select **On** (default).

Network Setup	
Auto Setup	◀ On ▶
IP Address	133 . 123 . 108 . 157
Subnet Mask	255 . 255 . 255 . 0
MAC Address	

Manual Setup

This setup requires the data listed below. You can get this data from either your ISP or the configuration utility for your DSL/cable modem or router.

- 1 Press **MENU** and ◀ or ▶ to select the **PREFERENCES** menu.
- 2 Press ▲ or ▼ to highlight **Network Setup**, and then press **OK**.
- 3 Press ▼ to highlight **Auto Setup**, and then press ◀ or ▶ to select **Off**.
- 4 Press ▼ to highlight **IP Address** field, and then use the Number buttons on the remote control to input the IP Address.

Network Setup	
Auto Setup	Off
IP Address	133 . 123 . 108 . 157
Subnet Mask	255 . 255 . 255 . 0
MAC Address	

- 5 Press ▼ to highlight the **Subnet Mask** field, and then use the Number buttons to input the Subnet Mask.
- 6 Press **OK**.

Text services

This television has a multi-page text memory, which takes a few moments to load. It offers two **Modes** of viewing text – **Auto** will display **Fasttext**, if available. **LIST** will save your four favourite pages.

Selecting modes

The text character set will be automatically chosen by the language setting in the **SETUP** menu.

- 1 Select **Teletext** from the **PREFERENCES** menu.
- 2 With ◀ or ▶ choose **Auto** or **LIST** then press **EXIT**.

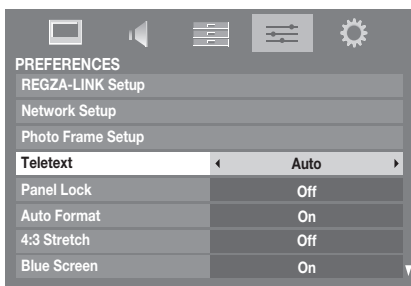

Text information

The TEXT button:

To view text services press **TEXT**. Press again to superimpose the text over a normal broadcast picture and again to return to normal viewing. Channels cannot be changed until text is cancelled.

The first text page shown will be the *initial* page.

Any text page can be accessed by entering the 3 digit page number using the numbered buttons, pressing the coloured buttons or pressing **P**^ to advance to the next page and **P**∨ to go back to the previous page.

Sub-pages

The pages on the screen will dynamically update as sub-pages are received.

If you open a page containing sub-pages, the sub-pages are automatically displayed in sequence. To quit automatic sub-page change, press ◀ or ▶.

Once selected, the sub-page you are viewing will be highlighted and, as the television loads any additional sub-pages, the colour of the numbers will change, indicating that these pages have been loaded.

These sub-pages will remain available to view until another page is chosen or, in normal TV mode, the channel is changed.

Navigating pages using Auto

If **Fastext** is available, four coloured titles will appear at the base of the screen.

To access one of the four given subjects, press the relevant coloured button on the remote control.

For further information on your particular text system(s), see the broadcast text index page or, consult your local Toshiba dealer.

Navigating pages using LIST

The four coloured choices at the bottom of the screen are numbers – 100, 200, 300 and 400, which have been programmed into the television's memory. To view these pages, press the relevant coloured buttons.

To change these saved pages, press the relevant coloured button and enter the 3 digit number. This number will change in the top left of the screen and in the coloured highlight.

Press **OK** to save. **Whenever **OK** is pressed, all four page numbers showing at the bottom will be saved and the previous ones will be lost.**

If **OK** is not pressed, the selection will be forgotten when the channel is changed.

Other pages may be viewed by entering the 3 digit page number – but **DO NOT** press **OK** or these pages will be saved.

Control buttons

Below is a guide to the functions of the remote control text buttons.

To display the index/initial page:

Press  to access the index/initial page. The one displayed is dependant on the broadcaster.



TEXT To display a page of text:

Press **TEXT** to display text. Press again to superimpose text over a normal picture. Press again to return to normal television viewing. Channels cannot be changed until this has been done.

To reveal concealed text:

To discover the solutions on quiz and joke pages press the  button.



To hold a wanted page:

At times it is convenient to hold a page of text. Press  and  will appear in the top left of the screen. The page will be held on screen until the button is pressed again.

To enlarge the text display size:

Press  once to enlarge the top half of the page, press again to enlarge the bottom half of the page. Press again to revert to normal size.

To select a page whilst viewing normal picture:

Enter the page number then press  , normal picture will be displayed. The television will indicate when the page is ready by changing the colour of the page number at the top of the screen. Press **TEXT** to view the page.

To display news flashes:

Select the news flash page for the chosen text service (see the index page of text service). The news flashes will be displayed as and when they are broadcast.

 **Remember to cancel text before changing channels - press the TEXT button twice.**

Questions and Answers

Below are the answers to some of the most common queries.
For more information go to www.toshiba.co.uk

Q Why is there no sound or picture?

A Check the television is not in standby mode. Check the mains plug and all mains connections.

Q There is a picture, but why is there little or no colour?

A When using an **external** source, for instance, a poor quality video tape, if there is little or no colour, improvements may sometimes be achieved. The colour is factory set to **Auto** to automatically display the best colour system.

To check that you have the best colour:

- 1 With the external source playing, select **Manual Settings** from the **SETUP** menu.

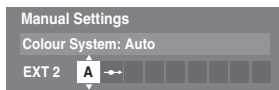

- 2 With **▲** or **▼** choose between **Auto**, **PAL**, **SECAM**, **NTSC 4.43** or **NTSC 3.58**.

Q Why doesn't the video/DVD being played show on screen?

A Make sure the VCR or DVD player is connected to the television as shown on page 8, and then select the correct input by pressing **EXT 2**.

Q Why is there a picture but no sound?

A Check all lead connections.
No sound or unacceptable format sound may be received.
Check the volume has not been turned down or that sound mute has not been selected.

Q Why is the VCR/DVD picture in black and white?

A Check that the correct **EXT 2** input setting has been chosen, **S-VIDEO** or **AV**. See **AV Connection** on page 49.

Q What else can cause a poor picture?

A Interference or a weak signal. Try a different television station. **Manual Fine Tuning** may help.

- 1 Select the **ATV Manual Tuning** menu. Highlight the station and press **OK**, then press **▶** to select **Manual Fine Tuning**.
- 2 Using **▲** or **▼** adjust to get the best picture and sound. Press **OK** and then **EXIT**.



Q Why don't the controls of the television work?

A Check that **Panel Lock** is not **On**.

Q Why doesn't the remote control work?

A Check that the mode switch on the remote control is in **TV** mode.
Check that the batteries aren't dead or inserted incorrectly.

Q Why is the digital channel locked?

A The channel has been selected in **Locked Channels** (see 'Digital Settings' section).

Q Why are some of the digital subscription channels unavailable?

A Your subscription needs upgrading. Contact your service provider.

Q Why is the soundtrack in English when a different audio language has been selected?

A The programme is currently being broadcast with an English soundtrack only.

Q Why is there incorrect or no sound when in DTV mode?

A Press **ODI/II** to ensure the hard of hearing option has not been selected.

Q What is DVB-T?

A Digital Video Broadcast via an aerial/antenna.

Q What is DVB-C?

A Digital Video Broadcast via a cable connection.

Q How are radio channels selected?

A Press **ATV/DTV** on the remote control and select **DTV RADIO**. Alternatively select from the **GUIDE**.

Q What can be done if the PIN number has been forgotten?

A Use the Master PIN code of 1276, then change to a number of your choice. Ensure that no-one else can use the Master PIN by removing the Owner's Manual.

Q Why are there vertical stripes on the screen when in PC mode?

A The **Sampling Clock** may need adjustment. Select **PC Settings** from the **SETUP** menu, highlight **Sampling Clock** and adjust until the lines clear.

Q Why are there horizontal stripes and/or blurred images on the screen when in PC mode?

A The **Clock Phase** may need adjustment. Select **PC Settings** from the **SETUP** menu, highlight **Clock Phase** and adjust until the picture clears.

Q Why when digital subtitles have been selected are they not showing on screen?

A Subtitles are not currently being transmitted by the broadcaster.

Q Why are there problems with analogue text?

A Good performance of text depends on a good strong broadcast signal. This normally requires a roof or loft aerial. If the text is unreadable or garbled, check the aerial. Go to the *main index* page of the text service and look for the *User Guide*. This will explain the basic operation of text in some detail. If further information is needed on how to use text see the *text section*.

Q Why is a page number visible at the top of the screen but no text?

A Text has been selected but Teletext information is currently unavailable on the current source.

Q Why are the colours wrong when an NTSC source is played?

A Connect the source via a SCART lead and play. Select **Manual Settings** from the **SETUP** menu.

1 Set the Colour to **Auto** and exit.

2 Go to the **PICTURE** menu and adjust the tint.

Q Why don't the devices connected via HDMI operate properly?

A Make sure to use cables with the HDMI logo **HDMI** (see page 9).

Some early HDMI equipment may not work properly with the latest HDMI TV products, due to new standard adoption. Try switching the HDMI settings **Lip Sync** and **INSTAPORT™** to **Off**.

Q Why don't the REGZA-LINK devices work?

A When the connected REGZA-LINK device does not work correctly after you have changed the settings of the device, turn off your television and unplug the power cord, and then plug and turn on again. Unplug the HDMI cable of the REGZA-LINK device and lead again.

Q Why is the REGZA-LINK logo still showing when the equipment has been disconnected?

A If the REGZA-LINK device is disconnected, the logo will disappear after approximately one minute.

Q What do the LEDs on the front of the television indicate?

A Check the table below.

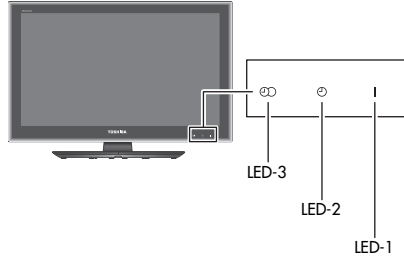

LED indication			Condition	Solution
LED-3	LED-2	LED-1		
Orange (Solid)	Green (Solid)	Green (Solid)	Power ON On Timer is set Programme Timer is set	-
Red (Solid)	Green (Solid)	Green (Solid)	Power ON On Timer is set Programme Timer is active	-
OFF	Green (Solid)	Green (Solid)	Power ON On Timer is set Programme Timer is NOT set	-
Orange (Solid)	OFF	Green (Solid)	Power ON On Timer is NOT set Programme Timer is set	-
Red (Solid)	OFF	Green (Solid)	Power ON On Timer is NOT set Programme Timer is active	-
OFF	OFF	Green (Solid)	Power ON On Timer is NOT set Programme Timer is NOT set	-
Orange (Solid)	Green (Solid)	Red (Solid)	Power OFF (Standby) On Timer is set Programme Timer is set	-

LED indication			Condition	Solution
LED-3	LED-2	LED-1		
Red (Solid)	Green (Solid)	Red (Solid)	Power ON (Standby) On Timer is set Programme Timer is active	-
OFF	Green (Solid)	Red (Solid)	Power OFF (Standby) On Timer is set Programme Timer is NOT set	-
Orange (Solid)	OFF	Red (Solid)	Power OFF (Standby) On Timer is NOT set Programme Timer is set	-
Red (Solid)	OFF	Red (Solid)	Power ON (Standby) On Timer is NOT set Programme Timer is active	-
OFF	OFF	Red (Solid)	Power OFF (Standby) On Timer is NOT set Programme Timer is NOT set	-
OFF	OFF	Green (Blinks)	Abnormal operation of BUS line.	Turn OFF the TV and unplug the power cord. Plug the power cord in again and turn ON the TV.
OFF	OFF	Red (Blinks)	Power protect detection.	
OFF	Green (Blinks)	OFF	Fan stopped. (55SV only)	
OFF	OFF	Orange (Blinks)	Back Light error.	

License Information

- THIS PRODUCT IS LICENSED UNDER THE AVC PATENT PORTFOLIO LICENSE FOR THE PERSONAL AND NONCOMMERCIAL USE OF A CONSUMER TO (i) ENCODE VIDEO IN COMPLIANCE WITH THE AVC STANDARD (AVC VIDEO) AND/OR (ii) DECODE AVC VIDEO THAT WAS ENCODED BY A CONSUMER ENGAGED IN A PERSONAL AND NONCOMMERCIAL ACTIVITY AND/OR WAS OBTAINED FROM A VIDEO PROVIDER LICENSED TO PROVIDE AVC VIDEO. NO LICENSE IS GRANTED OR SHALL BE IMPLIED FOR ANY OTHER USE. ADDITIONAL INFORMATION MAY BE OBTAINED FROM MPEG LA, L.L.C. SEE [HTTP://WWW.MPEGLA.COM](http://www.mpegla.com)
- MPEG Layer-3 audio coding technology licensed from Fraunhofer IIS and Thomson.

Cleaning the screen and cabinet...

Turn off the power, clean the screen and cabinet with a soft, dry cloth. We recommend that you **do not** use any proprietary polishes or solvents on the screen or cabinet as this may cause damage.

Disposal...

The following information is only for EU-member states:

Disposal of products

The crossed out wheeled dust bin symbol indicates that products must be collected and disposed of separately from household waste. Integrated batteries and accumulators can be disposed of with the product. They will be separated at the recycling centres.

The black bar indicates that the product was placed on the market after August 13, 2005.

By participating in separate collection of products and batteries, you will help to assure the proper disposal of products and batteries and thus help to prevent potential negative consequences for the environment and human health.

For more detailed information about the collection and recycling programmes available in your country, please contact your local city office or the shop where you purchased the product.



Disposal of batteries and/or accumulators

The crossed out wheeled dust bin symbol indicates that batteries and/or accumulators must be collected and disposed of separately from household waste.

If the battery or accumulator contains more than the specified values of lead (Pb), mercury (Hg), and/or cadmium (Cd) defined in the Battery Directive (2006/66/EC), then the chemical symbols for lead (Pb), mercury (Hg) and/or cadmium (Cd) will appear below the crossed out wheeled dust bin symbol.

By participating in separate collection of batteries, you will help to assure the proper disposal of products and batteries and thus help to prevent potential negative consequences for the environment and human health.

For more detailed information about the collection and recycling programmes available in your country, please contact your local city office or the shop where you purchased the product.



Information

Before connecting any external equipment, turn off all main power switches. If there is no switch, remove the mains plug from the wall socket.

Signal information for Mini D-sub 15 pin connector

Pin No.	Signal name	Pin No.	Signal name	Pin No.	Signal name
1	R	6	Ground	11	NC
2	G	7	Ground	12	NC
3	B	8	Ground	13	H-sync
4	NC*	9	NC	14	V-sync
5	NC	10	Ground	15	NC

* NC = not connected

Acceptable PC signals through the PC terminal

The PC input on this TV only accepts signal formats which are compliant with VESA-DMT as shown in the table below. Since some PCs input signals which are different from the resolution and frequency described in the table below, the following phenomenon may occur; incorrect display, false format detection, picture position failure, blur, or judder. In this case, set the monitor output format on your PC to conform to a signal in the table below.

Format	Resolution	V. Frequency	H. Frequency	Pixel Clock Frequency	VESA Standard (DMT)
VGA	640 × 480	59.940Hz	31.469kHz	25.175MHz	●
		72.809Hz	37.861kHz	31.500MHz	●
		75.000Hz	37.500kHz	31.500MHz	●
SVGA	800 × 600	56.250Hz	35.156kHz	36.000MHz	●
		60.317Hz	37.879kHz	40.000MHz	●
		72.188Hz	48.077kHz	50.000MHz	●
		75.000Hz	46.875kHz	49.500MHz	●
XGA	1024 × 768	60.004Hz	48.363kHz	65.000MHz	●
		70.069Hz	56.476kHz	75.000MHz	●
		75.029Hz	60.023kHz	78.750MHz	●
WXGA	1280 × 768	59.995Hz	47.396kHz	68.250MHz	●
		59.870Hz	47.776kHz	79.500MHz	●
		74.893Hz	60.289kHz	102.250MHz	●
	1360 × 768	60.015Hz	47.712kHz	85.500MHz	●
SXGA	1280 × 1024	60.020Hz	63.981kHz	108.000MHz	●
		75.025Hz	79.976kHz	135.000MHz	●

Acceptable video or PC signals through the HDMI terminals

The HDMI inputs on this TV only accept VGA, SVGA, XGA, WXGA, and SXGA signal formats which are compliant with VESA as shown in the table below. Since some PCs and HDMI or DVI devices input signals which are different from the resolution and frequency described in the table below, the following phenomenon may occur; incorrect display, false format detection, picture position failure, blur, or judder. In this case, set the monitor output format on your PC, HDMI or DVI device to conform to a signal in the table below.

Format	Resolution	V. Frequency	H. Frequency	Pixel Clock Frequency	VESA Standard
480i	720 × 480i	59.940/60.000Hz	15.734/15.750kHz	27.000/27.027MHz	
576i	720 × 576i	50.000Hz	15.625kHz	27.000MHz	
480p	720 × 480p	59.940/60.000Hz	31.469/31.500kHz	27.000/27.027MHz	
576p	720 × 576p	50.000Hz	31.250kHz	27.000MHz	
1080i	1920 × 1080i	59.940/60.000Hz	33.716/33.750kHz	74.176/74.250MHz	
1080i	1920 × 1080i	50.000Hz	28.125kHz	74.250MHz	
720p	1280 × 720p	59.940/60.000Hz	44.955/45.000kHz	74.176/74.250MHz	
720p	1280 × 720p	50.000Hz	37.500kHz	74.250MHz	
1080p	1920 × 1080p	59.940/60.000Hz	67.433/67.500kHz	148.352/148.500MHz	
1080p	1920 × 1080p	50.000Hz	56.250kHz	148.500MHz	
1080p	1920 × 1080p	24.000Hz	27.000kHz	74.250MHz	
VGA	640 × 480	59.940/60.000kHz	31.469/31.500kHz	25.175/25.200MHz	●
		72.809Hz	37.861kHz	31.500MHz	●
		75.000Hz	37.500kHz	31.500MHz	●
SVGA	800 × 600	56.250Hz	35.156kHz	36.000MHz	●
		60.317Hz	37.879kHz	40.000MHz	●
		72.188Hz	48.077kHz	50.000MHz	●
		75.000Hz	46.875kHz	49.500MHz	●
XGA	1024 × 768	60.004Hz	48.363kHz	65.000MHz	●
		70.069Hz	56.476kHz	75.000MHz	●
		75.029Hz	60.023kHz	78.750MHz	●
WXGA	1280 × 768	59.995Hz	47.396kHz	68.250MHz	●
		59.870Hz	47.776kHz	79.500MHz	●
		74.893Hz	60.289kHz	102.250MHz	●
	1360 × 768	60.015Hz	47.712kHz	85.500MHz	●
SXGA	1280 × 1024	60.020Hz	63.981kHz	108.000MHz	●
		75.025Hz	79.976kHz	135.000MHz	●

AUDYSSEY_{EQ} Audyssey EQ technology

Manufactured under license from Audyssey Laboratories. U.S. and foreign patents pending. Audyssey EQ is a registered trademark of Audyssey Laboratories.

Audyssey EQ is based on the award-winning Audyssey MultEQ technology. It is the first-ever room equalization solution that can achieve optimum sound for a large listening area and it is featured in many high end home theater products. Audyssey EQ is used in the TV tuning process to calculate an equalization solution that corrects time and frequency response problems in TV systems. This results in clear, rich sound with more intelligible dialog.

Specifications and accessories

DVB-T Broadcast systems/channels		Broadcast systems/channels	
UK	UHF 21-68	PAL-I	UHF UK21-UK69
France	VHF 05-10 (VHF 01-05) UHF 21-69	PAL-B/G	UHF E21-E69 VHF E2-E12, S1-S41
Germany	VHF 05-12 UHF 21-69	SECAM-L	UHF F21-F69 VHF F1-F10, B-Q
Austria	VHF 05-12 UHF 21-69	SECAM-D/K	UHF R21-R69 VHF R1-R12
Switzerland	VHF 05-12 UHF 21-69		
Italy	VHF 05-12 (D,E,F,G,H,H1,H2) UHF 21-69		
Spain	UHF 21-69		
Netherlands	VHF 05-12 UHF 21-69		
Greece	VHF 05-12 UHF 21-69		

Video Input PAL, SECAM, NTSC 3.58/4.43

External connections

EXT 1	Input	21-pin SCART	RGB, A/V
EXT 2	Input	21-pin SCART	A/V, S-video
EXT 3	Input	Phono jacks Phono jacks	Y, P _B /C _B , P _R /C _R Audio L + R
EXT 3	Input (Side)	Phono jack Phono jacks	Video, S-video Audio L + R
HDMI 1/2/3	Input	HDMI™ (Audio LIP SYNC, INSTAPORT™, RGB Range supported)	
HDMI 4	Input (Side)	HDMI™ (Audio LIP SYNC, INSTAPORT™, RGB Range supported)	
PC	Input	Mini D-sub 15-pin Analog RGB signal	
PC/HDMI 1	Audio	3.5mm mini jack	Audio
Digital Audio Output (S/PDIF)	Optical		
Output to Active Super Woofer	Phono jack		
Fixed Audio Output	Phono jacks	Audio L + R	
LAN port	RJ-45		
USB port	Interface version: USB 2.0 USB class: Mass Storage File system: FAT12, FAT16 and FAT32		
SD card slot	Interface version: SDHC File system: FAT12, FAT16 and FAT32		

Stereo Nicam
2 carrier system

Visible Screen Size (approx.) Model 46 117cm
55 140cm

Display 16:9

Sound output (at 10% distortion) Main 10W + 10W

Power consumption (approx.) Model 46SV 243W
55SV 315W

Standby Model 46SV 0.4W
55SV 0.4W

Dimensions (approx.) Model 46SV 78cm (H) 116cm (W) 35cm (D)
55SV 90cm (H) 136cm (W) 41cm (D)
(Height dimension includes foot stand)

Weight (approx.) Model 46SV 34.0kg
55SV 45.5kg

Headphone socket 3.5mm stereo

Operating condition Temperature 5°C - 35°C (41°F - 94°F)
Humidity 20 - 80% (non-condensing)

Accessories Remote control
2 batteries (AAA, IEC R03 1.5V)
ULCS software (Limited Edition) CD-ROM
Clip
Cleaning cloth (to clean the cabinet and control panel)

DVB is a registered trademark of the DVB Project

© Toshiba Information Systems (U.K.) Limited
All rights reserved.
Reproduction in whole or part without written permission is strictly prohibited.

Toshiba Information Systems (UK) Ltd

Consumer Products Division,
Weybridge Business Park,
Addlestone Rd,
Weybridge, Surrey, UK
KT15 2UL

Specification is subject to change without notice.