

TOSHIBA

The power to open people's eyes



32ZP18P
36ZP18P



colour television

owner's manual

Contents

SETTING UP

For your safety – Some <i>do's</i> and <i>don'ts</i> for you to be aware of and other points to follow	3
Your new television's remote control – an at-a-glance guide	4
Connecting the speakers	5
Connecting and turning on your new TV	6
Choosing the language and system, Auto tune	7
Auto tune continued	8
Manually tuning your TV – an alternative to <i>Auto tune</i>	9
Swapping programme positions and programme skip	10

USING YOUR TV

General controls – changing programme position, sound control, bass/treble/balance	11
Widescreen viewing – Superlive, Cinema, Subtitle, 14:9, Wide, 4:3	12
Picture adjustments – picture size/position, WSS – Widescreen Signalling	13
Picture adjustments – picture preferences, scan mode, digital noise reduction, picture still, blue screen	14

SPECIAL SOUND EFFECTS

Dolby Digital	15
Dolby Pro Logic – Surround Test Mode	16
Digital Surround Processor – Surround Sound Features	17

TELETEXT

Teletext – setting up	18
Teletext – Auto and List modes	19
Teletext – control buttons	20

ADDITIONAL FEATURES

The timer and time display – informing the TV to turn on/off and time display	21
Panel lock – disabling the buttons on the front of the TV	21
Stereo and bilingual transmissions – stereo or dual language broadcasts	21
AV connections and input selection – input and output sockets for connected equipment	22

CONNECTING OTHER EQUIPMENT

Back connections	23
Front connections and controls	24

FOR YOUR GUIDANCE

The Menus – a display of the main on-screen menus for your reference	25
Questions and Answers	26
Index, Specifications and Accessories – information on your television	28

For your safety

This equipment has been designed and manufactured to meet international safety standards but, like any electrical equipment, care must be taken if you are to obtain the best results and safety is to be assured. So, please read the points below for your own safety. They are of a general nature, intended to help you with all your electronic consumer products and some points may not apply to the goods you have just purchased.

Air Circulation...

Leave at least 10cm clearance around the television to allow adequate ventilation. This will prevent the TV from overheating and consequential possible damage to the TV. Dusty places should also be avoided.

Heat Damage...

Damage may occur if you leave the TV in direct sunlight or near a heater. Avoid places subject to extremely high temperatures or humidity, or locations where the temperature is likely to fall below 5°C (41°F).

Mains Supply...

The mains supply required for this equipment is 230v AC 50Hz. Never connect to a DC supply or any other power source. DO ensure that the TV is not standing on the mains lead. DO NOT cut off the mains plug from this equipment, this incorporates a special Radio Interference Filter, the removal of which will impair its performance. In the UK, the fuse fitted in this plug is 13A, and is approved by ASTA or BSI to BS1362. It should only be replaced by a correctly rated and approved type and the fuse cover must be refitted. IF IN DOUBT PLEASE CONSULT A COMPETENT ELECTRICIAN.

Do...

DO read the operating instructions before you attempt to use the equipment.

DO ensure that all electrical connections (including the mains plug, extension leads and inter-connections between pieces of equipment) are properly made and in accordance with the manufacturers' instructions. Switch off and withdraw the mains plug before making or changing connections.

DO consult your dealer if you are ever in doubt about the installation, operation or safety of your equipment.

DO be careful with glass panels or doors on equipment.

Do not...

DONT remove any fixed cover as this may expose dangerous voltages.

DONT obstruct the ventilation of the equipment, for example, with curtains or soft furnishings. Overheating will cause damage and shorten the life of the equipment.

DONT allow electrical equipment to be exposed to rain or moisture.

DONT place hot objects such as candles or nightlights on, or close to, the equipment. High temperatures can melt plastic and lead to fires.

DONT use makeshift stands and NEVER fix legs with wood screws. To ensure complete safety, always fit the manufacturer's approved stand or legs with the fixings provided according to the instructions.

DONT listen to headphones at high volume, as such use can permanently damage your hearing.

DONT leave equipment switched on when it is unattended, unless it is specifically stated that it is designed for unattended operation or has a standby mode. Switch off using the switch on the equipment and make sure your family know how to do this. Special arrangements may need to be made for infirm or handicapped people.

DONT continue to operate the equipment if you are in any doubt about it working normally, or it is damaged in any way – switch off, withdraw the mains plug and consult your dealer.

ABOVE ALL – NEVER let anyone, especially children, push anything into holes, slots or any other openings in the case – this could result in a fatal electric shock.

NEVER guess or take chances with electrical equipment of any kind – it is better to be safe than sorry.

Your new television's remote control

Simple, at-a-glance reference of your remote control's buttons...

F button – use with the colour buttons to select additional teletext features and with the VTR buttons for a **TOSHIBA DVD** player. It also increases the speed of most functions.

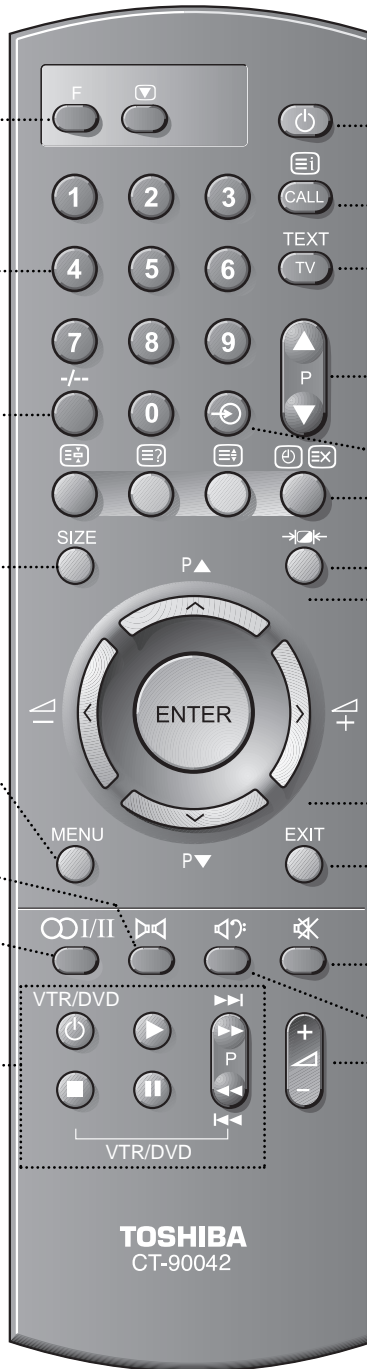

For On/Standby mode

To bring up on-screen information and for the teletext initial/index function.

To display teletext

To change programme positions and teletext pages

To select input from external sources

Teletext control buttons

Selectable picture preferences

To change programme positions and teletext pages

To alter the volume

When using menus the arrows move the cursor on the screen up, down, left or right. ENTER to confirm your selection.

To exit Menus

To mute the sound

Super Woofer

To alter the volume

Number buttons

1 or 2 digit programme selection

Widescreen mode selection

On-screen Menus

Dolby Surround

Stereo/bilingual reception

Please see page 25 for details of the main on-screen menus

These buttons will operate your **TOSHIBA VIDEO** and **DVD**. For the **DVD** you must press the **F** button at the same time...

to switch ON/OFF, press

to STOP, press

to PLAY, press

to PAUSE, press

to FAST FORWARD/SKIP, press

to REWIND/SKIP, press

... For quick reference to topics, please see the **INDEX** at the end of this manual.

The batteries... and the effective range of the remote...

Carefully slide the back cover downwards to reveal the battery compartment and make sure you insert the batteries the right way round.

All Toshiba batteries are Cadmium and Mercury free. Suitable battery types for this remote are R03 or AAA.

Do not throw your old batteries into a fire, dispose of them in a designated disposal area. Do not combine a used, old battery with a new one or mix battery types.

The performance of the remote control will deteriorate beyond a distance of five metres or outside an angle of 30 degrees from the centre of the TV.

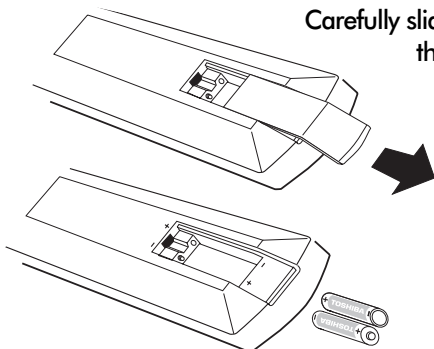

Connecting the speakers

! WARNING: do not attempt to share external speakers with your Hi-Fi as serious damage may occur.

In order to enjoy the full benefits of Surround Sound it is necessary to connect two rear surround speakers and two front extension speakers.

When connecting external Hi-Fi speakers, they must be 8 ohm, 10W minimum. The front speakers should be positioned either side of the TV and will deliver the left and right sound. The internal speakers will then deliver the centre channel required to enjoy Dolby Digital.

When connecting external speakers always make sure that the power is OFF.

Extension Front Speaker connections

To connect extension front speakers simply press the connector and insert the cable. You must now set the switch to **EXT** as shown.

Always make sure that the lead with the stripe (or raised edge) is connected to the RED terminal and the other (smooth) lead is connected to the BLACK terminal.

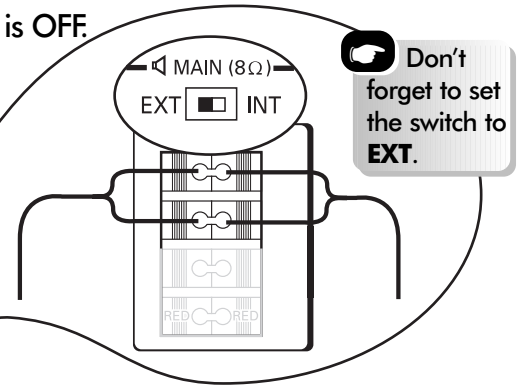

Main Speaker

TV

Main Speaker



These are suggested positions only. Place your speakers to suit and adjust the balance as necessary.

Surround Speaker

Surround Speaker

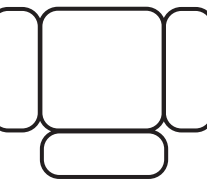

Surround Speaker connections

To connect surround speakers simply press the connector and insert the cable. These speakers should be sited in line with the normal viewing position

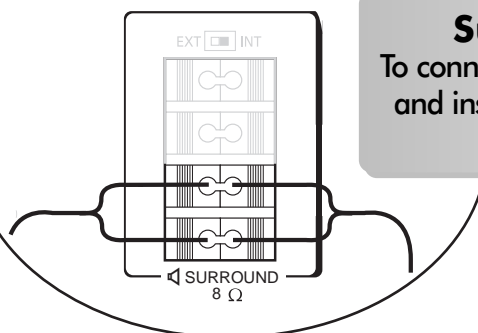

Connecting and turning on your new TV

To conserve energy it is best to turn your TV off and not to leave it in Standby, unless the timer has been set.

The TV back connections...

Connect the aerial to the socket on the rear of the television. If you use a Set Top Box and/or a video recorder it is essential that the aerial cable is connected through the Set Top Box and/or through the video recorder to the television.

DO NOT CONNECT SCART LEADS UNTIL THE TELEVISION IS FULLY TUNED.

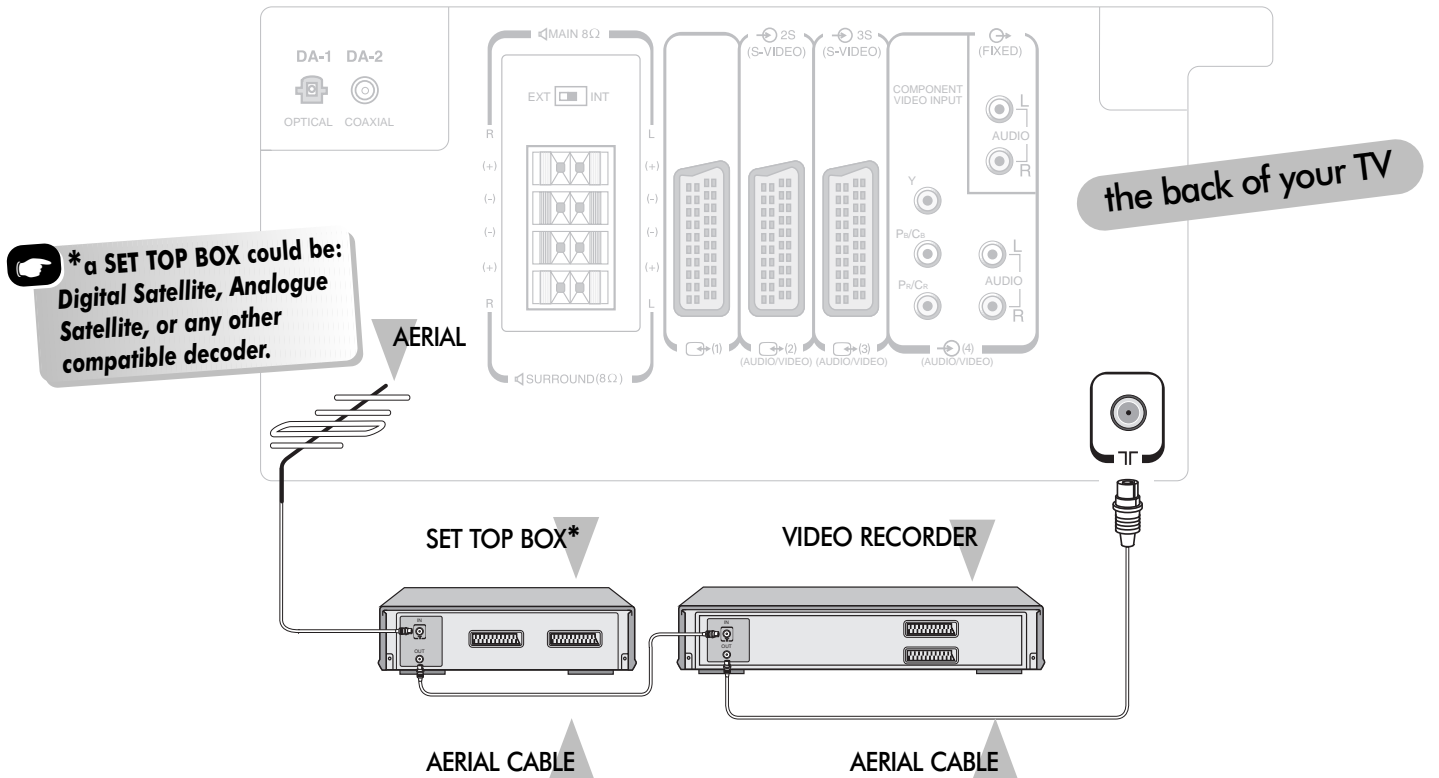

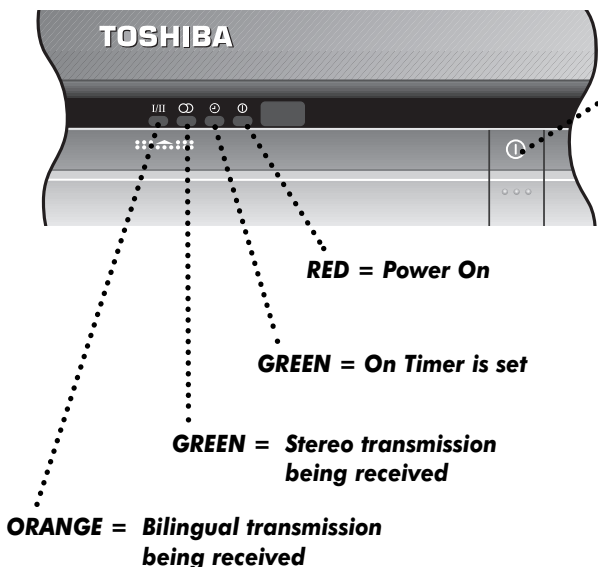

...and switching your new TV on...



On the front of the TV...

If the red power-on light is unlit, press the POWER button on the front of the TV to switch the set on and then press a number button on the remote control to see the screen.

...and with the remote control:

Press the Standby Button : This allows you to put the set into standby mode when leaving the TV unattended for short periods of time. To return to TV mode press the  button, or any of the numbered buttons on the remote control. The picture may take a few seconds to appear.



Choosing the language and system, Auto tune

The on-screen menus can be viewed in different languages and you will need to choose the system necessary for where you live.

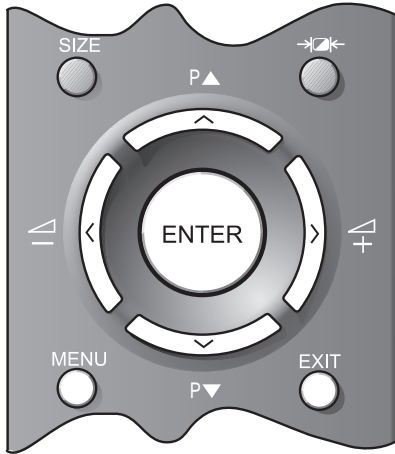

To select your language...

- 1 Press the **MENU** button, and use either the **<** or **>** button to select the **FEATURE MENU** from the top bar.



- 2 Now repeatedly press the **▼** button until **Language** is highlighted in the **FEATURE MENU** options.

FEATURE MENU

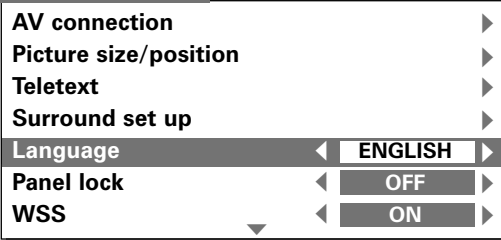

EXIT : To exit

- 3 Press the **<** or **>** button to view the language options available. As you view each language, the wording on the menus will automatically change for you.
- 4 When you have got the right language, press the **EXIT** button. All the displays will now appear in that language.

To select your system... *Continental Europe only*

Before running **Auto tune** it is important that you select your desired **System** as described here. Should you also wish to tune to alternative Systems this must be done manually, after using **Auto tune**. See page 9.

- 1 Press the **MENU** button on the remote control, and then either the **<** or **>** button to select the **SET UP** option from the top bar.

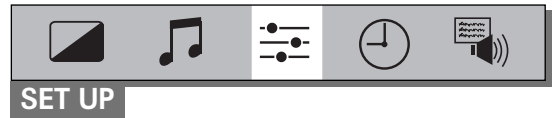

- 2 Now press the **▼** button to highlight **System** from the **SET UP** menu options and then the **<** or **>** button repeatedly to select your **System**:

B/G - Continental Europe, **D/K** - Eastern Europe, **I** - UK, **L1(12) L2(8)** - France

SET UP

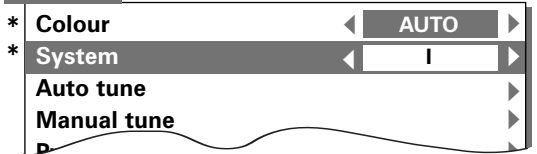

You can now run Auto tune...

First of all turn on your Set Top Box and tune to a main channel. Also turn on the video recorder and set it to Standby – this will enable your television to identify and allocate the necessary programme positions.

- 1 Press the **▼** button to highlight **Auto tune** while you are in the **SET UP** menu. Press the **>** button.

You will be informed that all previous settings will be lost.

- 2 Press the **ENTER** button on the remote control to begin the search for available stations.
- 3 **▶▶▶▶▶** will flash and each station found will appear in succession on the screen.

Allow the television to complete the search.

AUTO TUNE

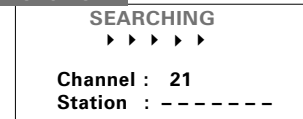

EXIT : To exit

Auto tune continued

UK and Continental Europe settings

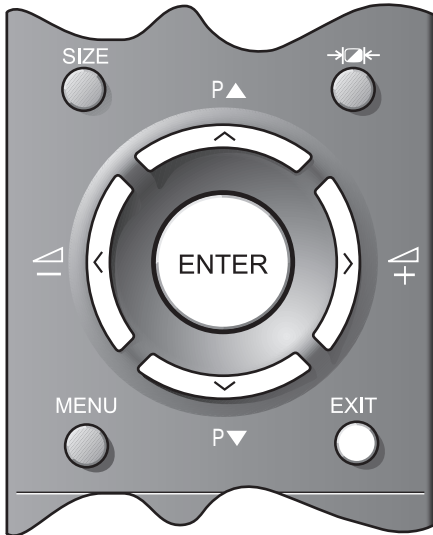

For the UK only...

AUTO TUNE

Prog.	Station	Channel
1	BBC1	22
	BBC1	39

...Your TV may display different Channel numbers...

ENTER : To store
EXIT : To exit

- When the search is complete, the screen will display a list of all the available BBC1 signals.
- If more than one is shown press the **▼** or **▲** button to highlight and view the choices.
Choose the best picture and sound.
- Press the **ENTER** button to store BBC1 on programme position 1.
Note: You can only choose one BBC1 station at this stage.
- Position 2 will appear showing the BBC2 choices. Repeat the steps above to allocate the required signal.

- Repeat for all the remaining programme positions you wish to tune including a Set Top Box, if connected. *If there are no signals for any programme positions, simply press the **ENTER** button to move on to the next one. Press **EXIT** to finish and one of the number buttons to view the TV.*

For Continental Europe only...

AUTO TUNE

Prog.	Station	Channel
1	-----	01
	-----	02
	-----	05
	-----	07
	-----	08
	-----	12

...Your TV may display different Channel numbers...

ENTER : To store
EXIT : To exit

- When the search is complete press the **▼** or **▲** button to move through the list to select the channel you wish to allocate to programme position 1.
- Press **ENTER** to store.
You can use the **Programme swap** facility later if required, see page 10.
- Repeat the procedure for all the programme positions you wish to store including the Set Top Box. If you wish to leave a programme position free, for use in the future, store an unwanted channel on it.
- Press the **EXIT** button when you have finished and press the number buttons to view a channel of your choice, e.g. 01. To tune any stations on different SYSTEMS, use the **Manual tune** facility from the **SET UP** menu, as described on page 9.

! YOU MAY NOW CONNECT YOUR SCART LEADS

Manually tuning your TV

As an alternative to **Auto tune**, you can tune-in your Toshiba television manually using **Manual tune**. For example: if you have used **Auto tune** but wish to tune-in a station on another **SYSTEM** (see page 7) or, you are unable to connect the TV to your video with a Scart lead.

Manual tune...

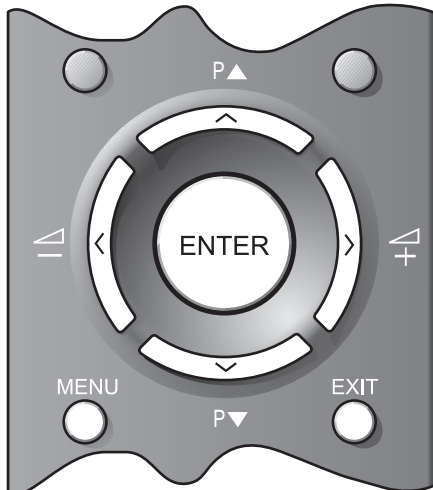

! If you cannot connect your television to the video recorder using Scart leads you will need to allocate a programme position on the television for the video recorder. Insert a pre-recorded tape and press **PLAY** on the remote control, then **Manual tune**...

- 1** From the top menu bar select **SET UP** and with the **✓** button select **Manual tune**.

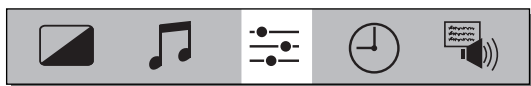

SET UP

* Colour	◀	AUTO	▶
* System	◀	I	▶
Auto tune			▶
Manual tune			▶
Programme swap			▶
Manual fine tuning			▶
Programme skip	◀	OFF	▶

EXIT : To exit

- 2** Press the **➤** button twice to start the search.

MANUAL TUNE

◀ Back			
Search	◀	>>>	▶
Programme no.	◀	01	▶
Channel	◀	024	▶
Station	◀	-----	▶

ENTER : To store

EXIT : To exit

- 3** **>>>** (**Search**) will flash and the television will show the channel numbers whilst the search is progressing.
- On finding a station it will show on the television.
- 4** If you do not wish to store it, press the **➤** button to continue the search. If you do wish to store it press **✓** to highlight the **Programme no.** and then press **◀** or **➤** to select the number you wish to store it on. (We suggest 0 for the video recorder.)
- 5** Press **✓** to highlight **Station** and **◀** or **➤** to select a **Station** name if required.
- 6** Press **ENTER** if you wish to store the broadcast displayed.
- 7** To repeat the process, highlight **Search** and press the **➤** button to look for the next station.
- 8** Press **EXIT** when you have finished.

PLEASE NOTE This TV has direct channel entry if the channel numbers are known.

Select the **Manual tune** screen.
Enter the required programme number, then enter the appropriate channel number.
Select the station name and press **ENTER** to store.

* Continental Europe only

Swapping programme positions and programme skip

After **Auto tune** if you want to swap the position of certain programmes you can. **Program swap** is an easy way of storing each channel on the programme position of your choice. **Program skip** stops the viewing of certain channels.

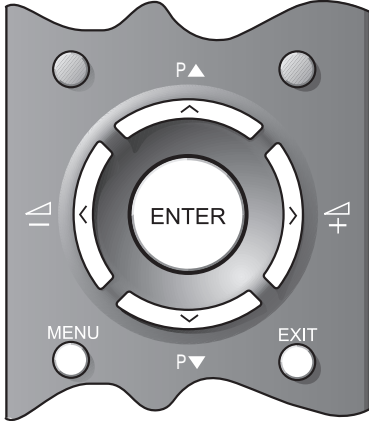

To swap programme positions...

- 1 Press the **MENU** button and then the **<** or **>** button to select the **SET UP** option from the top bar.

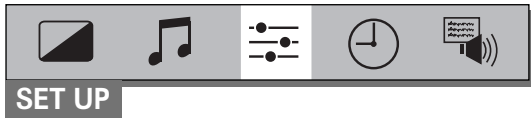

- 2 Press **▼** to highlight **Programme swap** and **>** to select.

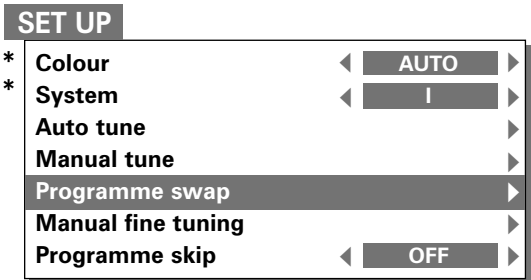

EXIT : To exit

- 3 The list of stations is now showing. With the **▼** or **▲** button highlight the station you want to move and press **ENTER** to select. The station you are moving will show on the bar at the bottom.

PROGRAMME SWAP

Prog.	Station	▲ Channel
1	BBC1	22
2	BBC2	28
3	ITV	25
4	CH4	32
4	CH4	32

ENTER : To swap **EXIT** : To exit

- 4 With the **▼** or **▲** buttons again, move through the list to your preferred position
- 5 Press **ENTER** again. You will see that the programme positions have now been swapped.

Skipping programmes...

To prevent certain programmes from being viewed, for example, a certain film by your children whilst your are out for the evening, you can skip the programme position and take the remote control with you. The television will still function as normal using the controls on the front of it, but the set will not show the skipped programme position.

- 1 Using the remote, select the channel to be skipped.
- 2 Select the **SET UP** menu, and then **Programme skip**.
- 3 Press **>** to turn **Programme skip ON**.

...remember... you must select each channel separately.

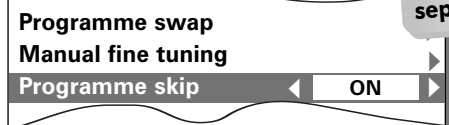

- 4 Then press the **EXIT** button. Change to an un-skipped channel before switching off the TV.
- 5 It is necessary to repeat from **step 1** for all the channels to be skipped. The **skipped** channels cannot now be selected by the **▼ P ▲** buttons or by the controls on the front of the TV but can still be accessed by the number buttons on the remote control.

An * on the screen indicates a skipped programme position.

- 6 To turn **Programme skip OFF**, repeat the procedure on the chosen channel.

...Remember... each channel has to be INDIVIDUALLY selected and set with Programme skip ON or OFF.

General controls

Pressing the **F** button at the same time will speed up most functions...

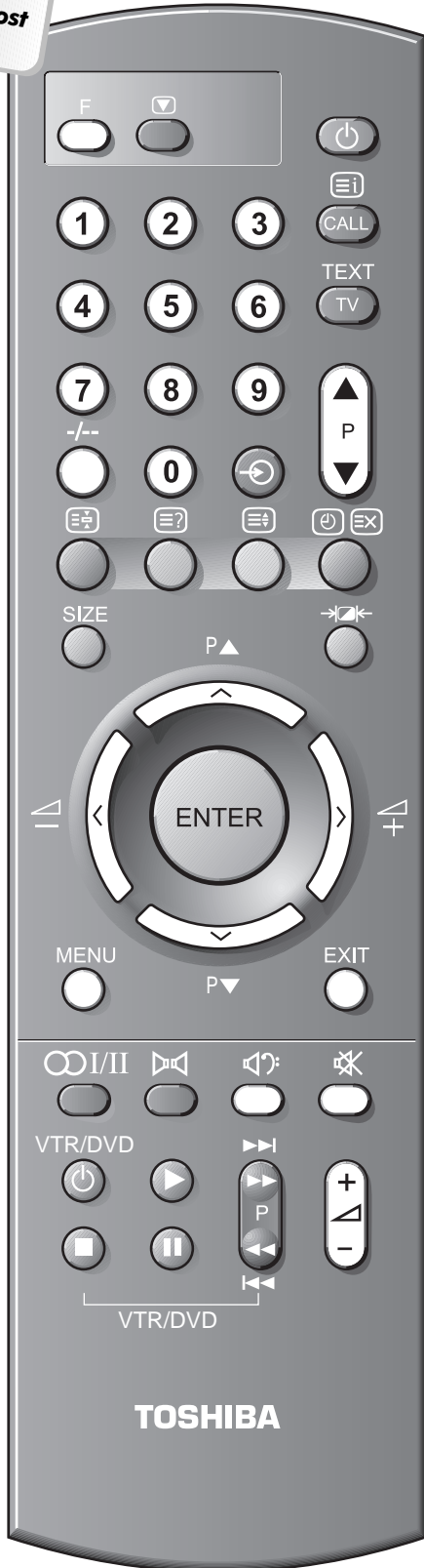

Selecting and changing programme position...

Enter the desired programme position number using the numbered buttons on the remote control.

For programme positions *below* 10, press the **-/--** button to select **—** on the screen then enter the desired programme position number.

For programme positions *above* 9, press the **-/--** button to select **— —** then enter the desired two digit programme position number.

You can also change the programme position by using the **▼ P ▲** button or the **▼** or **▲** buttons.

The programme position will be displayed on the screen with the Stereo/Mono indicator, described on p21.



Sound control...

Volume

Press the **▲ — +** button or the **<** and **>** buttons to adjust the volume.



Sound Mute

Press the **⊗** button to turn the sound off. Press it again and the sound will return.

Super Woofer – to enhance the depth of sound

Press the **🔊** button repeatedly to turn the **Super Woofer** on and off. Press the **<** or **>** button to adjust the effect.

Bass, treble and balance adjustments...



SOUND

Bass	+01	◀ — ● — ▶
Treble	00	◀ — ● — ▶
Balance	00	◀ — ● — ▶

EXIT : To exit

Press the **MENU** button on the remote control, and the **<** or **>** button to select the **SOUND** option from the top bar.

Press the **▼** button to highlight **Bass**, **Treble** or **Balance** from the **SOUND** menu and then the **<** or **>** button to change the setting.

Widescreen viewing

This set is capable of showing broadcasts in a number of formats. Depending on the type of broadcast being transmitted you may select between **SUPER LIVE**, **CINEMA**, **SUBTITLE**, **14:9**, **WIDE** and **4:3**.



Press the **SIZE** button repeatedly to view the options available.

SUPER LIVE

This setting will enlarge the image to fit the screen by stretching the image horizontally, holding the correct proportions at the centre of the image.

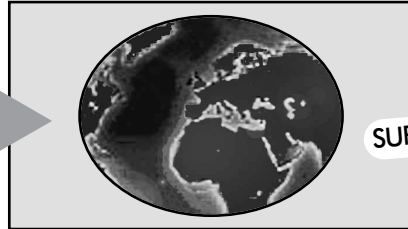

SUPER LIVE

Experiment with them all until you find a style that suits you...

CINEMA

When watching 'letterbox format' films/video tapes, this setting will eliminate or reduce the black bars at the top and bottom of the screen by zooming in and selecting the image without distortion.

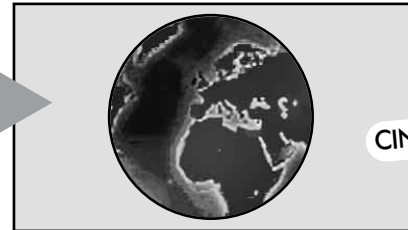

CINEMA

SUBTITLE

When subtitles are included on a letterbox format broadcast, this setting will raise the picture to ensure that all the text is displayed.



SUBTITLE

! Whenever the **MENU** button is pressed the picture size setting will change while the menus are **ON** the screen. This is to ensure the menus do not overlap the edges of the viewable area.

14:9

Use this setting when watching a 14:9 broadcast.

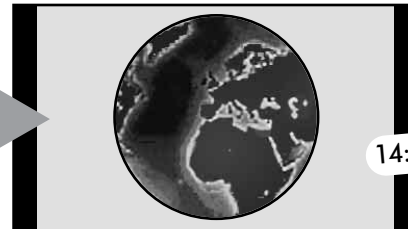

14:9

WIDE

Use this setting when watching a widescreen DVD, widescreen video tape or a 16:9 broadcast (when available). Due to the range of widescreen formats (16:9, 14:9, 20:9 etc.) you may see black bars on the top and bottom of the screen.

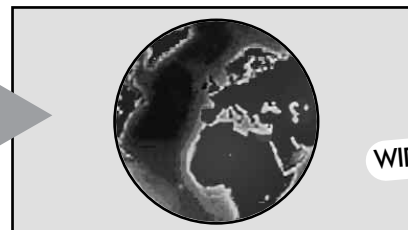

WIDE

4:3

Use this setting to view a true 4:3 broadcast.

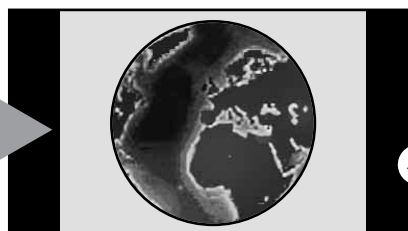

4:3

Picture adjustments

Adjustment to the horizontal and vertical position and height of the picture may be made to suit your viewing preferences.

Picture size/position

1 Press the **MENU** button, and use the **>** button to select **FEATURE MENU**.

2 Now repeatedly press the **∨** button until **Picture size/position** is highlighted.

FEATURE MENU



FEATURE MENU

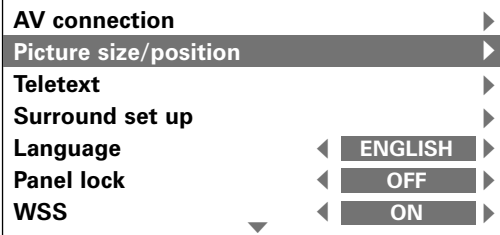

EXIT : To exit

3 Press the **>** button to view the options available for the picture format you have selected.

4 With the **∧** and **∨** buttons, highlight an option and with the **>** button select.

5 Now use the **<** or **>** buttons to adjust the settings as required and press **EXIT** when you have finished.

In **SUPER LIVE**:

PICTURE SIZE/POSITION



EXIT : To exit

! The options available to you when in the Picture size/position screen will vary depending upon the widescreen format you have previously chosen, as detailed on page 12.

WSS – Widescreen Signalling

When this TV receives a true Widescreen picture and WSS is ON, it will automatically be displayed in Widescreen format, irrespective of the TV's previous setting.

1 Press the **MENU** button, and use either the **<** or **>** button to select the **FEATURE MENU**. Use **∨** to move down to **WSS**.



2 Using the **<** or **>** buttons turn **WSS ON** or **OFF**.

FEATURE MENU

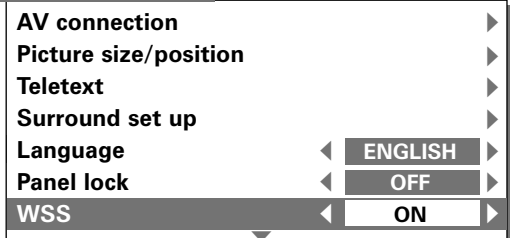

EXIT : To exit

Picture adjustments continued

This television offers you the choice of personalising the picture style to suit your own preferences.

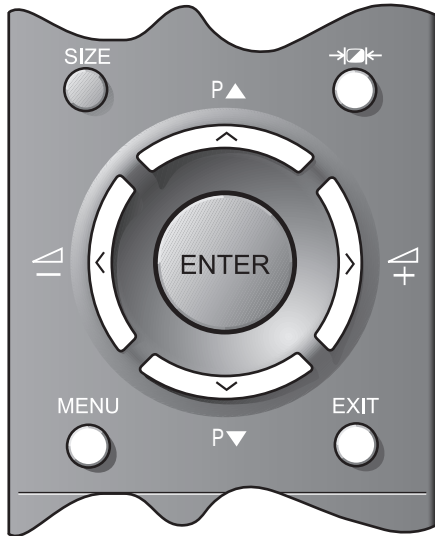

Picture preferences

- By pressing the button you can view the different picture styles available:
Picture mode-1 to *3* for preset options and *Picture mode-M* is for your own settings:
- So, to set your own, choose **PICTURE** from the top menu bar.



PICTURE

Contrast	75	
Brightness	50	
Colour	50	
Tint	00	
Sharpness	00	
Scan mode	100Hz	
DNR	AUTO	

EXIT : To exit

Within this **PICTURE** menu you have the options to adjust the **Contrast**, **Brightness**, **Colour**, **Tint** and **Sharpness**.

- Using the or button alter to suit your taste.

The Tint can only be adjusted on a signal from an NTSC video recorder or DVD player when the television is in AUTO colour mode.

Scan Mode

- Select **Scan mode** from the **PICTURE** menu.
- With the or button select between **100Hz** and **NATURAL**, to choose the picture you prefer – the difference may only be slight.

DNR – Digital Noise Reduction

DNR enables you to 'softer' the screen representation of a weak signal.

- Select **DNR** from the **PICTURE** menu. Select between **AUTO** and **OFF** to obtain the best picture. The differences may not always be noticeable.

Picture Still

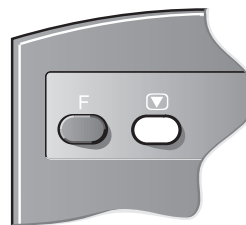

Using the latest technology this television's 100Hz double scanning plus digital picture processing produces a flicker-reduced picture. In addition, a *still* – similar to freeze frame on a VTR – can be held on the screen.

- Pressing the button will hold an image on the screen. Press again to return to TV mode.

Blue Screen...

When no signal is being received, the TV will turn off the sound and switch the screen to blue. After 20 minutes the TV will switch to Standby mode.

- In the second section of the **FEATURE MENU** select **Blue screen ON** or **OFF**.

Use the and buttons to move up and down this two-part menu.

FEATURE MENU

Blue screen	ON
-------------	----

EXIT : To exit

Dolby Digital

Dolby Digital is available from DVD players, some games console players, etc. These must be connected using a Scart or phono lead for the picture **AND** an optical or a coaxial cable for the sound see page 23.

Dolby Digital

Arrange the speakers around your normal viewing positions (as shown on page 5) and then make sure that the TV is set up as follows:

- 1 The DVD is connected to the TV using phono leads to the COMPONENT VIDEO INPUT or a Scart lead to Scart 3, **and** an optical or coaxial cable to the optical/coaxial sockets, DA-1 or DA-2.
- 2 The **Digital input** in the **AV CONNECTION** menu (see page 22) is set to **EXT3** if Scart 3 is used or **EXT4** if the DVD is connected to COMPONENT VIDEO INPUT.
- 3 If external front speakers are connected the external switch (found on the back of the TV) is set to **EXT**.
- 4 Rear speakers are connected and the **Rear Speaker** option in the **Surround set up** menu is set to **YES**.



DELAY TIME...

If you sit a long way from the TV and close to the rear speakers the sound from the rear will reach you before the sound from the front. You can use a higher setting in the **Delay time** option to restore the correct balance.

- 1 From the **FEATURE MENU** select **Surround set up**.
- 2 With **Delay time** highlighted, use the < or > button to change the setting to a value that suits you.
- 3 Press **EXIT** when you have finished.

! If rear speakers are **NOT** selected in the **Surround set up** menu, you will not hear any sound from your rear speakers.

Adjustments



! Alternatively, use the **Test mode** in the **SURROUND SET UP** menu.

- 1 Set the **volume** and **balance** of the front speakers to your preference.
- 2 Play a Dolby Digital source and press the button on the TV's remote control. The title, e.g. **Dolby Digital 3/2**, is an indication of the channels available from your current sound source, see the table.
- 3 To adjust the levels, use the or button to select the centre and two rear speakers in turn. Press either the < or > button to adjust. The number of adjustable speakers will depend upon the signal received from the DVD player.
- 4 To cancel the test press the **EXIT** button.

Dolby Digital

- 1/0 = Centre speaker only.
- 2/0 = Front Left and Front Right only.
- 2/1 = Front Left and Front Right + Rear Left and Rear Right combined.
- 2/2 = Front Left and Front Right + Independent Rear Left and Independent Rear Right.
- 3/0 = Front Left and Front Right and Centre. No Rear Speakers.
- 3/1 = Front Left and Front Right and Centre + Rear Left and Rear Right combined.
- 3/2 = Front Left and Front Right and Centre + Independent Rear Left and Independent Rear Right.

! If the DVD playing is recorded in Dolby Pro Logic, i.e. 4 channel stereo (front left, front right, centre and rear) the TV will detect the 4 channels.

In this instance, when the **Surround Test Mode** is run the TV will cycle through the four channels in use.

In order to get full Dolby Digital, the DVD player must be connected using the coaxial or optical links.

Dolby Pro Logic

Dolby Pro Logic – available on many TV broadcasts in addition to video tapes. Uses a combination of 4 speaker channels – front-left, centre, front-right and two rear. If external front speakers are not connected, these channels will be delivered through the speakers in the TV.

Dolby Pro Logic

SURROUND SET UP

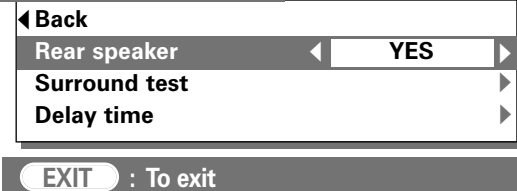

- 1 From the **FEATURE MENU** select **Surround set up**.
- 2 Using the < or > buttons turn **Rear speaker** to **YES**.

! **YES** in the **Rear Speakers** option must be chosen for the **Test Mode** below to function...

Surround Test Mode

! **Remember...** Check that Rear speakers are connected and the **Rear speaker** option in the **Surround set up** menu is set to **YES**.

! If you cannot connect rear speakers try Dolby 3 Stereo, but you must have external front speakers connected and the external switch set to **EXT**.

- 1 Sit in your usual viewing position.
- 2 Press the button to bring up the **SURROUND** menu. With **Dolby Pro Logic** selected, **EXIT** and go to the **FEATURE MENU** to select the **SURROUND TEST** from the **Surround set up** menu.

SURROUND TEST

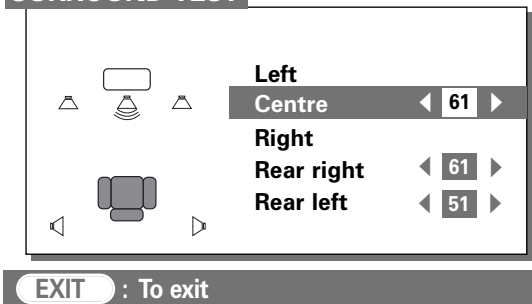

- 3 Use the < and > buttons to adjust.



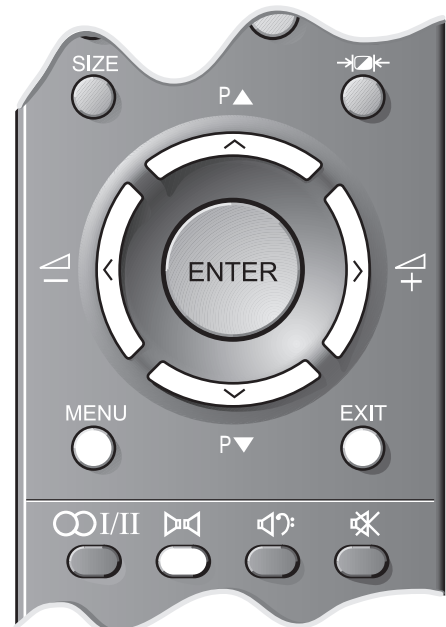





! The **TEST** will play a 'white noise' through each speaker in turn. The display will show you which speaker is in play, adjustments may be made whilst it is highlighted.



! Inserting the headphone jack will mute the sound from all speakers and deliver a normal stereo left and right signal. There are no Dolby Digital or Surround effects available when using headphones.

Digital Surround Processor

Please note: **Hall**, **Theatre**, **Disco**, and **Stadium** effects are only available on a stereo signal. **Pseudo surround** works on both mono and stereo signals. All of the Digital surround modes are adjustable, the method of adjustment being described below, is the same for all the Digital Surround effects.

- 1 Press the  button to bring up the **SURROUND** menu.
- 2 Press the  or  button repeatedly to select the digital mode which best suits the type of broadcast.
- 3 Then press the  button to access the adjustments screen and with the , ,  and  buttons, adjust the levels as required.

SURROUND SOUND uses a combination of 4 speakers – front-left, front-right and two rear speakers.

...if you choose to adjust one Digital Surround mode, you will not effect the others.

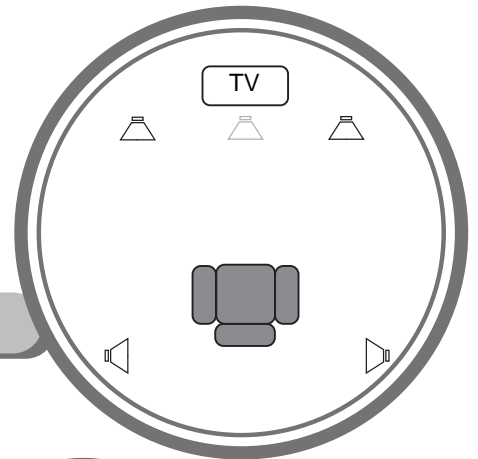

Surround Sound: Hall

To reproduce in the living room the surround effects similar to those experienced in a large concert hall. *Ideal for TV programmes or music video tapes.*



Surround Sound: Pseudo

To create a synthetic sound effect for movies and TV shows recorded in mono.



Surround Sound: Theatre

To reproduce the surround effects similar to those experienced in a movie theatre filled with a rich warm sound. *Ideal for movies with stereo sound.*



Surround Sound: Stadium

To reproduce the surround effects similar to those experienced in a large football or baseball stadium packed for a live game.



Surround Sound: Disco

To create the atmosphere of a room so full of music that it seems to engulf the listener. *An ideal sound mode for listening to pop videos.*

Surround Sound: Off

Uses only the front left and right speakers. This mode can be selected for watching news broadcasts and the like which require no special sound features.

Teletext – setting up

This TV offers two ways of viewing text – **AUTO** and **LIST** which are explained on the next page.

Selecting the character set and viewing mode and general information

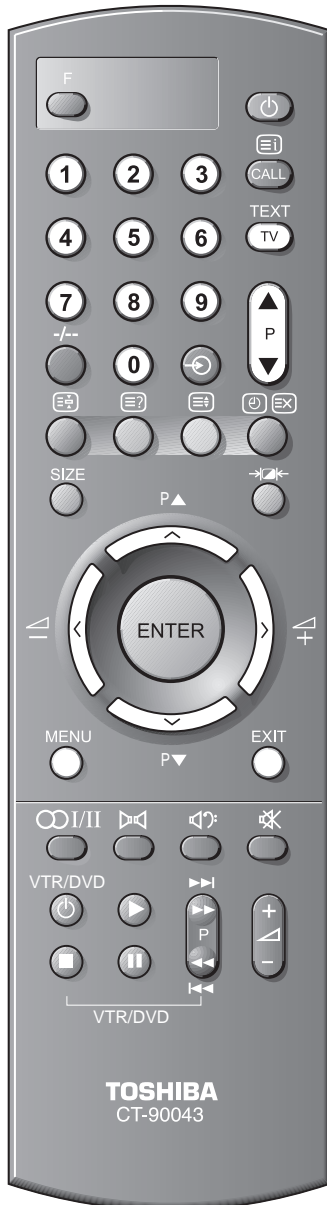

Selecting characters and modes

Before using teletext you can choose the correct alphabet (**Character**) and whether to view in **List** or **Auto** mode (explained on the next page).

- 1 From the **FEATURE** menu, use the \wedge or \vee button to highlight **Teletext** and then the \rightarrow button to select.

- 2 With **Character** highlighted, use the \rightarrow button to select your required character set: **CHARACTER-1** or **CHARACTER-2**:

TELETEXT



CHARACTER-1 for:

English	Français	Deutsch
Italiano	Español	Jazyk
Svenska	Português	Türkçe

CHARACTER-2 for:

Po polsku	Romana	Jazyk
Srpski	Français	Deutsch
Italiano	Svenska	

- 3 To select the **Mode**, with the \vee button highlight **Mode**.
- 4 With the \leftarrow and \rightarrow buttons choose **Auto** or **List**.
- 5 Press **EXIT** to finish.

About teletext

The **TEXT TV** button:

TEXT TV Pressing the **TEXT TV** button once will bring up the teletext screen. Pressing it again will split the TV screen in two, with the TV picture and the text screen side by side. A third press will return you to the normal TV screen. You need to return to normal viewing if you wish to change channels.

When you first press the **TEXT TV** button to access the text service, the first page you see will be the **initial** page.

In **Auto** mode this displays the main subjects available and their relevant page numbers.

In **List** mode you will see your chosen **INITIAL** page (explained on the next page).

To access any teletext page, enter the 3 digit page number, using the numbered buttons on the remote control, e.g. 430.

To advance to the next page of teletext, press the **P** \blacktriangle button, to go back to the previous page press the **P** \blacktriangledown button.

Teletext continued

– Auto and List modes

Selecting pages

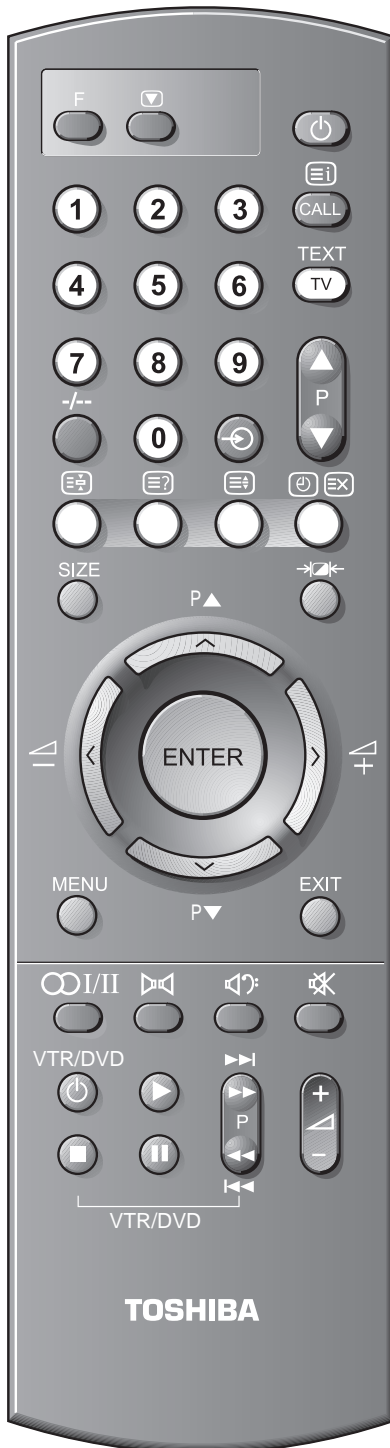

There are two **Modes**: **Auto** will display **FASTEXT**, if available. **List** will display your four favourite pages. In either mode, as an alternative to the coloured buttons you can access a page by entering a 3-digit number, using the buttons on the remote control.

Auto

Press the **TEXT TV** button to access teletext.

In **Auto** mode, if **FASTEXT**, is available, you will see four coloured titles at the base of the screen.

To access one of the four given subjects, press the relevant coloured button on the remote control, corresponding to the title.

For further information on your particular text system(s), see the broadcast teletext index page or, consult your local Toshiba dealer.

List

Press the **TEXT TV** button to select teletext.

To programme the set to hold your 4 favourite pages in memory. Select the **LIST** function by pressing the **GREEN** button.

Enter the first page number (*in purple on screen*) then press the **GREEN** button. Repeat for each of the desired 4 pages.

To view these 4 selected pages press the **RED** button for **ROTATE**. An arrow head will point to the page number of the *next* favourite page that will be displayed on pressing the **RED** button again.

On programme positions 0-9 you can pre-programme an **INITIAL** page. Select the **INITIAL** function by pressing the **YELLOW** button. P*** will appear in the top left corner of the screen. Enter the required 3 digit page number. As you key in the desired **INITIAL** page, for example page 220, the numbers will replace the ***.

Whenever text is first selected on this programme position this **INITIAL** page will be displayed.

The rest of the text control buttons are explained on the next page...

Teletext continued

– control buttons

Now you have set up teletext, below is a guide to the remote control teletext buttons and their functions.

Using the buttons on the remote control...

Remember: Cancel text before changing channels. Press TEXT TV button twice.



1 To display a page of teletext: **TEXT TV**

Press the **TEXT TV** button to display teletext. Press again to split the TV/teletext screen to continue viewing the normal broadcast picture whilst viewing a text page. Press a third time to return to normal TV. You cannot change programmes until you return to normal TV.

2 To display an index/initial page:



In **AUTO** mode

Press the  button to access index pages. The one displayed is dependant on the broadcaster.

In **LIST** mode

Press the  button to return to your **INITIAL** page.

3 To hold a wanted page: and

At times it is convenient to hold a page of teletext. Press the **F** and the  buttons and the word **HOLD** will appear in the top left of the screen. Press  again to release.



4 To reveal concealed text: and

Some pages cover topics such as quizzes and jokes. To discover the solutions press the **F** and the  buttons.





5 To enlarge the teletext display size: and

Press the **F** and the  buttons once to enlarge the top half of the page, press again to enlarge the bottom half of the page. Press again to revert to the normal size.

6 To view a TV programme whilst waiting for your text page: and

When in teletext mode, if a page selection is made and then the **F** and the   buttons are pressed, a normal picture will be displayed. The TV will indicate when the page is present by displaying the title bar of the text page at the top of the screen. Press the **TEXT TV** button to view the page.

To display news flashes:

To view news flashes as they are broadcast, select the news flash page for the particular teletext service (see the index page of teletext service). Press the **F** and the   button. The news flashes will be displayed as and when they are broadcast. Press the **F** and the   buttons to cancel the display.

Remember... to use the teletext buttons for these four functions, you must press the **F** button at the same time.

You must cancel the news flash page before changing channels.

The timer, time display, panel lock and stereo/bilingual transmissions

The Timer

You can tell the TV to turn itself ON or OFF after a certain time.

- 1 Select the **TIMER** option from the top menu bar.



TIMER

Off timer	00:00
On timer	01:30 P02

0-9 : To set
EXIT : To exit

- 2 Select the **On timer** (or the **Off timer**). If, for example, you want the TV to turn ON (or OFF) in one and a half hours time, enter 01:30 using the numbered buttons on the remote control.

- 3 When setting the **On timer**, you must enter the programme position number you want to watch. You must put the set into Standby mode by pressing the button.

Any equipment connected with Scart leads must also be put into Standby mode to prevent them being displayed when the timer switches on.

When the **On timer** has been set, the GREEN On timer indicator on the front of the TV will be lit (see page 6).

*If the **On timer** has been set, you do not have to wait to watch the television. You can bring the set back to life by pressing the button. However, the GREEN timer light will stay on until the set time period has passed, at which point the TV will go to the chosen channel.*

- 4 To cancel the **On timer**, enter zero in each position including the programme position.

The Time Display

The time display facility allows you to see the current time on the TV screen.

If you press the **F** button and the button on the remote control whilst watching a normal TV broadcast you will see a time display from the broadcaster. It will remain on the screen for about 5 seconds.

Panel Lock

Panel lock allows you to disable the buttons on the front of the TV set. You can though, still use all of the buttons on the remote control.

- 1 From the **FEATURE MENU** select **Panel lock** and choose **ON** or **OFF** with the or buttons.



FEATURE MENU

AV connection	▶
Picture size/position	▶
Teletext	▶
Surround set up	▶
Language	◀ ENGLISH ▶
Panel lock	◀ ON ▶
WPC	▶

When Panel lock is ON, you will be reminded on the screen when you press any of the front panel buttons. Once the set has been switched off it can ONLY be brought out of standby using the remote control.

Stereo and Bilingual transmissions...

If stereo or dual language broadcasts are transmitted the lights on the front of the TV will be lit. The word Stereo or Dual will appear on the screen, disappearing after a few seconds. The display will reappear each time you change programme positions, provided that the broadcast is in stereo. If the broadcast is not in stereo the word Mono will appear.

Stereo...

NICAM, MPX broadcasts can be in either Stereo or Mono.

- 1 Choose the required programme number.
- 2 Press the button repeatedly, to select between **Stereo** and **Mono**.

...and Bilingual

Bilingual transmissions are rare. If they are transmitted the word **Dual** will display.



- 1 Choose the required programme number and if the word **Dual** does appear press the button to select between **Dual 1**, **Dual 2** or **Mono**.

AV connections and input selection

...Please see page 23 for a clear view of the back connection recommendations...

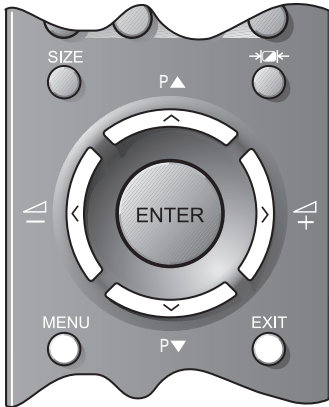
Defining your INPUT and OUTPUT sockets so that your television recognises connected equipment.



Most video recorders and Set Top Box receivers send a signal through the Scart lead to switch the TV to the correct *Input* socket. Alternatively you may select it with the external source selection button  on the remote control. Press  repeatedly until you see the picture on your equipment.



Digital Audio in the display indicated that the external source has been set as a digital audio input, see below. An **S** in the display, e.g. **EXT2S**, indicates the input is set for an S-Video signal.

Input Selection

SELECTING THE DIGITAL AUDIO SIGNAL



This set is provided with 2 digital audio inputs – DA-1 and DA-2 – so that, for example, a DVD player and a games console can stay permanently connected.

Having connected the video signal from your DVD to, say, COMPONENT VIDEO INPUT (**EXT4**) and from your games console to Scart 3 (**EXT3**) you will now need to connect the audio cables to the inputs on the back of the set, then match the two up.

- 1 If you have connected to **DA-1**, select **AV connection** from the **FEATURE MENU** and press the  button to highlight **Digital Input 1** then with the  or  buttons, select the appropriate video input, for example **EXT4** for the DVD player.

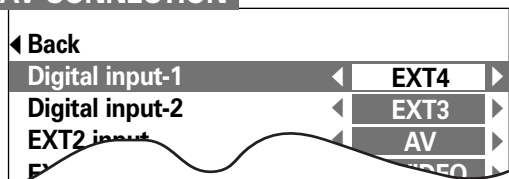
AV CONNECTION



- 2 Then for the 2nd connection, press the  button to highlight **Digital Input 2** then with the  or  buttons, select the appropriate video input, for example, **EXT3** for the games console.

SELECTING THE VIDEO SIGNAL

This feature allows you to specify the type of signal going into **Scarts 2 or 3** on the back of the television and the sockets on the front (Input 3). **AV** is the most common and comes from standard video recorders and Set Top Boxes whereas **S-VIDEO** signals are less common. (Please refer to the manufacturer's specification.)

- 1 From the **FEATURE MENU** select **AV connection** and with the  or  button select either **AV** or **S-VIDEO** as the required *input* for **EXT2** and **EXT3**.

AV CONNECTION

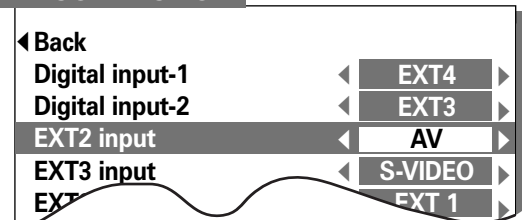



Selecting the OUTPUT signal for Scart 2

This feature enables you to select the source to *output* from Scart 2. e.g. If you connect a stereo Set Top Box to Scart 1 and a stereo video recorder to Scart 2, and select **EXT1** as the **EXT2** output (i.e. you will output the signal received through Scart 1 directly out to Scart 2), you will be able to record the stereo Set Top Box transmission in stereo.

- 1 Again, from the **FEATURE MENU** select **AV connection**.

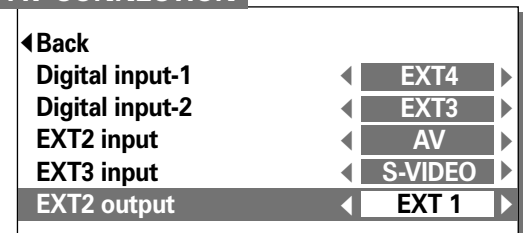
AV CONNECTION



- 2 Using the  or  buttons change the **EXT2** output option to either **Monitor**, **TV**, **EXT1** or **EXT3**.
Monitor = The picture on screen
TV = The last television programme selection.
EXT1 or **3** = the picture from equipment connected to Scart 1 or Scart 3.

Back connections

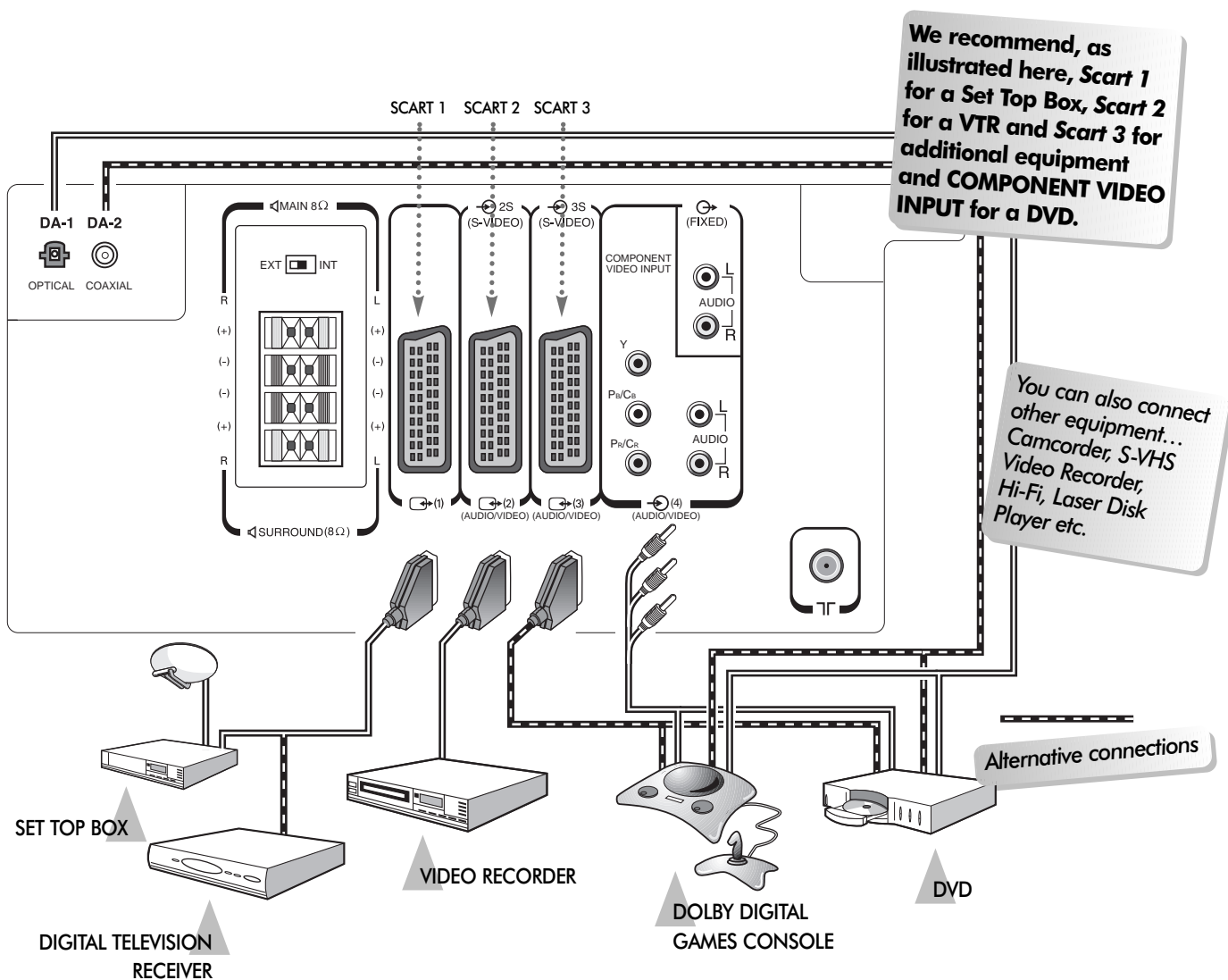

On the back of the TV are 3 Scart sockets, and a selection of phono sockets, all of which will enable you to connect a variety of equipment.

DA-1 and DA-2 enable the input of Digital Audio signals.

The phono sockets alongside the COMPONENT VIDEO INPUT sockets will accept L and R audio signals.

In addition there is a fixed external audio output which enables the connection to a suitable Hi-Fi unit.

If connecting S-VIDEO equipment, set the **INPUT** for **EXT2** or **EXT3** accordingly. See page 22.

Before connecting any external equipment, turn off all main power switches.

If your TV automatically switches over to monitor the connected equipment you can return to normal TV simply by pressing the desired programme position button.

To recall the connected equipment, press the **↺** button repeatedly to select between **EXT1**, **EXT2**, **EXT3** and **EXT4**.

Front connections and controls

You can connect a wide variety of external equipment via the sockets located behind the flap on the front of the TV. Press the centre of the flap to open it.

Front connections...

! DO NOT connect equipment to both the front and rear 3 terminals at the same time.

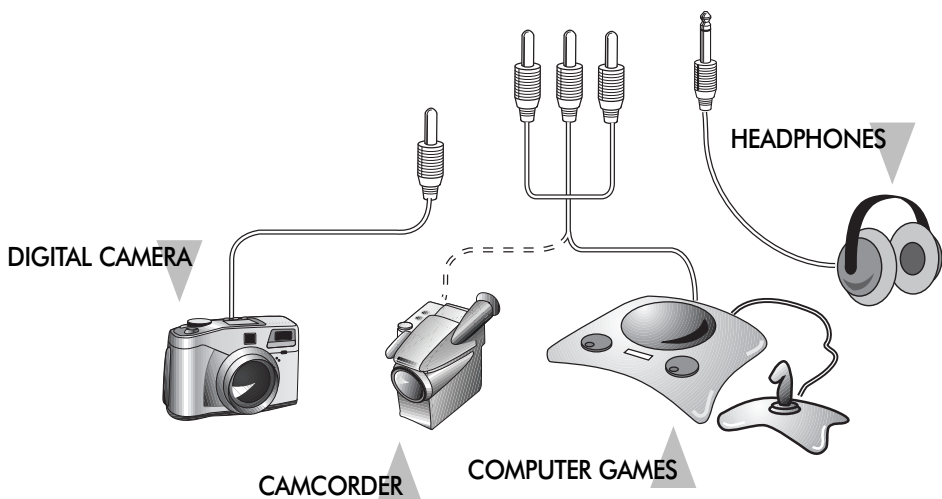
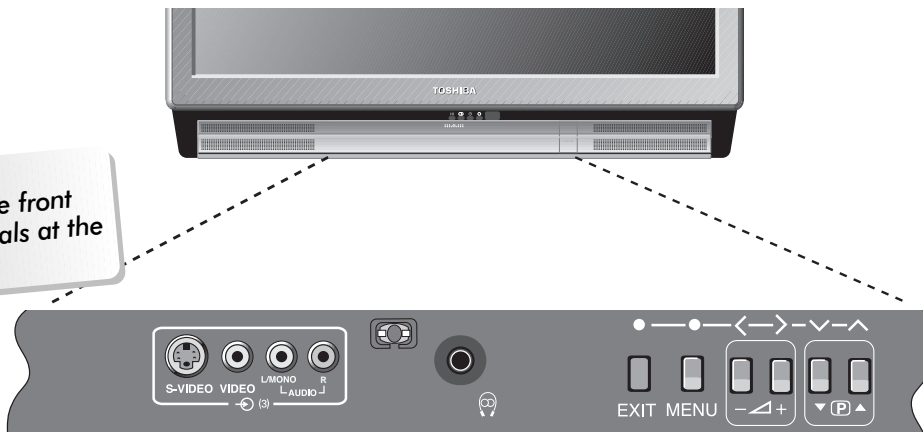

! Please always refer to the owner's manual of the equipment to be connected for full details.

Front controls...

Whilst all the necessary adjustments and controls for your new TV are made using the remote control, the buttons on the front of the TV may be used for some functions...

For example, to alter the volume press the — ▲ + buttons,

and to alter the programme position press the ▼ [P] ▲ buttons...

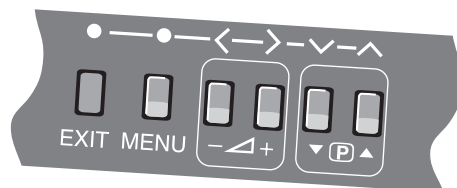

...press the **MENU** button and control the sound and picture features with the + — and ▼ [P] ▲ buttons.

Use **EXIT** to cancel the displays.

If you connect mono sound equipment to **Input 3**, connect the audio output of the equipment to the L/Mono socket on the TV.

To select the front Inputs, press the button until the display shows **EXT3** or **EXT3S** as described on page 22.

Before connecting any external equipment, turn off all main power switches.

Please note: Inserting the headphone jack will mute the sound from all speakers.

The on-screen menus

Press the **MENU** button on the remote control to see your top menu bar. This white menu bar will show five different topics shown in symbols. As you select each symbol by pressing the **◀** or **▶** button, its respective options will appear below. To use the options press the **▼** button on the remote control to move you down through them.

Using the Menus

The functions of each menu are described in detail throughout this Manual.

The PICTURE Menu



PICTURE

Contrast	75	◀	◌	▶
Brightness	50	◀	◌	▶
Colour	50	◀	◌	▶
Tint	00	◀	◌	▶
Sharpness	00	◀	◌	▶
Scan mode		◀	100Hz	▶
DNR		◀	AUTO	▶

EXIT : To exit

The SOUND Menu



SOUND

Bass	00	◀	◌	▶
Treble	00	◀	◌	▶
Balance	00	◀	◌	▶

EXIT : To exit

The SET UP Menu

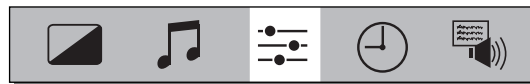

SET UP

* Colour		◀	AUTO	▶
* System		◀	I	▶
Auto tune				▶
Manual tune				▶
Programme swap				▶
Manual fine tuning				▶
Programme skip		◀	OFF	▶

EXIT : To exit

When watching a TV broadcast...

When watching an external source...

SET UP

Colour		◀	AUTO	▶
--------	--	---	------	---

EXIT : To exit

* Continental Europe only

The TIMER Menu



TIMER

Off timer	00:00
On timer	00:00 P01

0-9 : To set
EXIT : To exit

The FEATURE Menu



FEATURE MENU

AV connection		▶
Picture size/position		▶
Teletext		▶
Surround set up		▶
Language		◀ ENGLISH ▶
Panel lock		◀ OFF ▶
WSS		◀ ON ▶

EXIT : To exit

Press the **▼** button to access the second part of the FEATURE MENU

FEATURE MENU

Blue screen		◀ ON ▶
-------------	--	--------

EXIT : To exit

Questions and Answers...

...For quick reference to topics, see the **INDEX** at the back of this manual.

If you experience what seem like problems operating your TV, we recommend you read through these simple checks.

Q Why is there no sound or picture?

A Check that the mains switch is on and check all the connections. Press the Standby button  on the remote control to make sure that the TV is not in Standby mode.

Q There IS a picture, but why is there little or no colour?
(CONTINENTAL EUROPE ONLY)

A The television is factory set to **AUTO** in the **SET UP** menu and usually chooses the best colour system. If the picture source is of poor quality, the **AUTO** function may not work. In which case you can view the colour options available...

1 From the **SET UP** menu select **Colour**.



SET UP

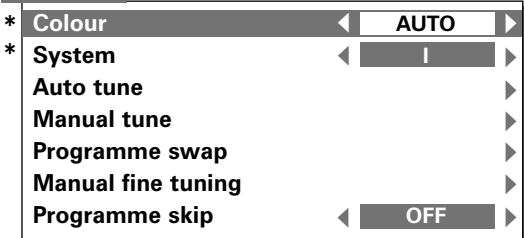

EXIT : To exit



2 With the **<** or **>** button, choose between **AUTO**, **PAL**, **SECAM**, **NTSC 4. 43** or **3. 58**.

* Continental Europe only

Q Why are there coloured patches on the screen?

A These are often caused by magnetic field interference. Turn off the TV by the ON/OFF button on the front of the TV for ten minutes and then turn it on again. If there are any speakers nearby, reposition them away from the TV before turning the TV off.

Q I have a picture, but why have I no sound?

A Press the volume button **+**  **-** or the sound mute  button.

Q Can anything else cause a poor picture?

A Yes, interference or a weak signal. Try a different TV station to check.

Manual fine tuning may help:

1 Select **Manual fine tuning** from the **SET UP** menu.



SET UP

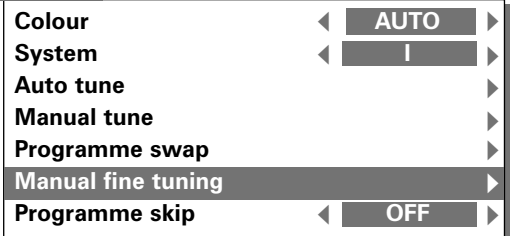

EXIT : To exit

2 With the **<** or **>** button adjust **Manual fine tuning** to optimise the picture.



Q Why can't I see the video tape I am playing?

A Make sure you have connected the VTR to the TV using a **Scart lead** and then select the correct input using the  button.

Q Why is the video recorder picture in black and white?

A The **input** socket maybe set to **S-Video** in the **AV CONNECTION** menu.

Q Why is the video picture good but there is no sound?

A ...Check Scart lead connection.
...Check **Digital Input OFF**. See **AV connections**.

Questions and Answers... continued



Q Why are the colours wrong when I play an NTSC source?

A Connect the source via a Scart lead and play. Select the **SET UP** menu.



- 1** Set the Colour to **AUTO** and exit.
- 2** Go to the **PICTURE** menu and adjust the tint.

Q Why am I having problems with teletext?

A Good performance of text depends on a good strong broadcast signal. This normally requires a roof or loft aerial. If the Text is unreadable or garbled, check your aerial. Go to the *main index* page of the teletext service and look for the *User Guide*. This will explain the basic operation of teletext in some detail. If you need further information on how to use text see the *teletext* section.

Q Why don't the controls on the front of the TV work?

A Check that **Panel lock** is not **ON** in the **FEATURE MENU**.

Q Why doesn't the remote control work?

A Check that the batteries aren't dead and that they are inserted correctly.

Q Why is there no Dolby Surround?

A If you are unable to obtain surround sound effects from the rear speakers whilst playing a Dolby Surround video tape, check that the video recorder is a stereo unit and is connected by a scart lead. Then check the **Surround set up** in the **FEATURE MENU**.

Q Why is there no Dolby Digital?

A ...If you are unable to obtain full Dolby Digital check: The **Rear Speaker** (in **Surround set up**) says **YES** and the equipment is either connected by a phono or optical link as well as through a Scart socket or **COMPONENT VIDEO INPUT**. Also check that the correct external source is selected i.e. **EXT3** or **EXT4** (in **AV connections**).

If you connect external front left and right speakers, you must set the External speaker switch to **EXT** to get the full benefit of Dolby Digital – if the switch is left on **INT** the external speakers will not function. **Turn the television off** before changing the position of the switch.

Q Why is there no sound from the external left and right speakers?

A ...Check the speaker switch has been set to **EXT**.

Cleaning the screen and cabinet...

After turning off the power, clean the screen and cabinet with a soft, dry cloth. We recommend that you **do not** use any proprietary polishes or solvents on the screen or cabinet as this may cause damage.

Disposal...

When the set reaches the end of its useful life please dispose of it in accordance with Local Government Regulations or at a recycling centre.

Subject	Page	Subject	Page
Audio Output	23	Programme Selection	11
Auto tune	7	Programme Skip	10
AV Connections	22	Programme Swap	10
Balance	11	Questions and Answers	26
Bass	11	Remote Control	4
Bilingual Broadcast	21	Scart	22
Blue Screen	14	Sharpness	14
Brightness	14	Sound Mute	11
Broadcast System	7	Speaker connections	5
Colour System (Continental Europe only)	26	Standby	6
Connections – back	23	Stereo	21
Connections – front	24	Super Woofer	11
Contrast	14	Surround Set Up – Digital surround processor	17
Direct Entry of Channels	9	Surround Set Up – Dolby Digital	15
Front Controls	24	Surround Set Up – Dolby Pro Logic	16
Headphone Socket	24	Switch on TV	6
Input Selection	22	Teletext	18
Installation	6	Time Display	21
Language	7	Timers	21
Main Menus	25	Tint	14
Manual fine tuning	26	Treble	11
Manual tune	9	Tuning a programme position for your VTR	9
Mono	21	Tuning – Auto	7
Noise Reduction	14	Tuning – Manual	9
Panel Lock	21	Volume	11
Picture Position	13	Widescreen Viewing	12
Picture Preferences	14	WSS – Widescreen Signalling	13
Picture Still	14		

Specifications and accessories

Broadcast systems/channels

PAL-I	UHF UK21-UK69
PAL-B/G	UHF E21-E69 VHF E2-E12, S1-S41
SECAM-L	UHF F21-F69 VHF F2-F10, B-Q
SECAM-D/K	UHF R21-R69 VHF R1-R12

Programme Positions 100

Stereo Nicam/MPX

Video Input PAL, SECAM, NTSC 3.58/4.43

External connections

EXT1	Input	21-pin Scart	RGB, A/V
EXT2	Input/Output	21-pin Scart	A/V, S-video, Selectable output
EXT3	Input (back) Input (front)	21-pin Scart 4-pin Phono jack Phono jacks	A/V, S-video S-video Video Audio L + R
EXT4	Input	Phono jacks Phono jacks	Y, P _B /C _B , P _R /C _R Audio L + R
Digital Audio Input		Optical or Coaxial	
Fixed Audio Output		Phono jacks	Audio L + R

Visible Screen Size

32ZP18P	76cm
36ZP18P	86cm
	16:9

Display

Sound output (at 10% distortion) Woofer

10 Watts + 10 Watts
13 Watts

Power consumption

Power consumption

32ZP18P	155Watts
36ZP18P	160Watts

Dimensions 32ZP18P 544mm (H) 750mm (W) 545mm (D)
Dimensions 36ZP18P 620mm (H) 855mm (W) 601mm (D)

Weight

32ZP18P	56kg (approx.)
36ZP18P	75kg (approx.)

Headphone Socket

3.5mm stereo

Accessories

Remote control
2 batteries (R03 or AAA)

© Toshiba Information Systems (U.K.) Limited

All rights reserved.

Reproduction in whole or part without written permission is strictly prohibited.

Manufactured under license from Dolby Laboratories. "Dolby", "Pro Logic", and the double-D symbol are trademarks of Dolby Laboratories. Confidential unpublished works. Copyrights 1992-1997 Dolby Laboratories. All rights reserved.

2356 5225

Toshiba Information Systems (U.K.) Limited

Consumer Products Division,
European Service Centre,
Admiralty Way, Camberley,
Surrey, GU15 3DT England

Specification is subject to change without notice.

Originated by Kensa Creative Solutions, Saltash, Cornwall.