

SANYO

Quick Setup Guide

Video Cassette Recorder
VHR-288E

- CONNECTIONS
- AUTO SETUP

Dear Customer,

Thank you for buying Sanyo. Please follow this Quick Setup Guide for an easy setup of your VCR.

For more details, please refer to the supplied instruction manual.

Accessories

Is everything in the box?

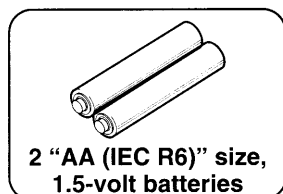
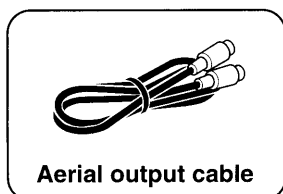
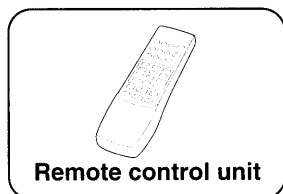
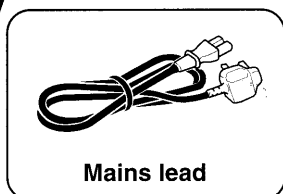
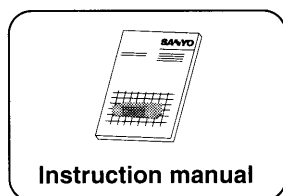

Caution concerning condensation

Be careful of condensation!

Condensation can form inside a VCR when it is suddenly moved from a cold place to a warm, humid one, or when a heater has been turned on to quickly heat the room.

Do not insert a video cassette if you use this VCR in areas subject to condensation.

Wait for 1 to 2 hours to completely eliminate condensation before using the VCR.

SETUP 1 CONNECTIONS

Aerial/RF connection

- 1 Disconnect the aerial cable from your TV, then connect it to the VCR.
- 2 Connect the supplied aerial output cable between the VCR and the TV.

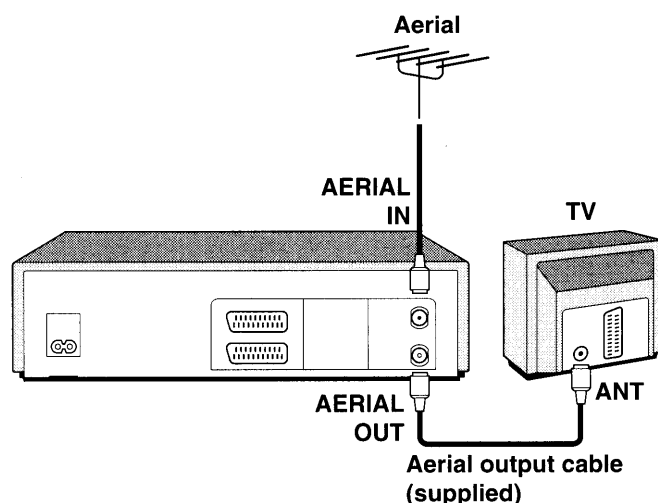

- 3 Connect the mains lead straight and firmly.

To a wall socket

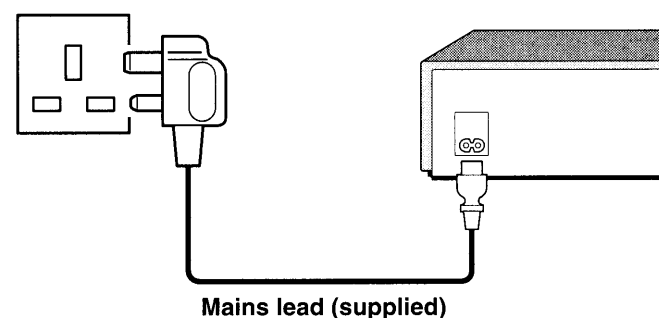

Note:

AUTO SETUP will start if the VCR is switched to the power on mode by pressing the **⏻/I** button. Go to "**SETUP2** AUTO SETUP".

SETUP 2 AUTO SETUP

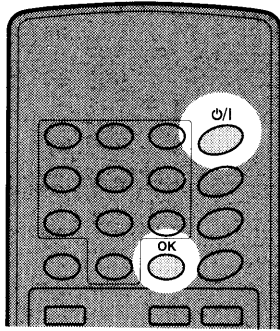

The AUTO SETUP function will do the following.

• Auto tuning

The VCR will automatically search and preset all the available TV stations in the area of use to programme position numbers (1 to 44).

• Auto sorting the TV stations

The TV stations available in your area will be automatically preset in order starting from programme position "1" to programme position "6", as follows.

Programme position	"1"	"2"	"3"	"4"	"5"	"6"
TV station	BBC1	BBC2	ITV	C4	CH5	*1 or *SKY1

*1

For areas where there is a satellite broadcasting service, the TV station with the lowest frequency will be preset to this programme position number. (Select SKY 1 on the cable box.)

*SKY 1

During AUTO SETUP and when the satellite receiver is connected at RF, ensure the satellite receiver is switched on and SKY 1 selected. The satellite programme will be stored in programme position "6".

• Auto video channel (RF output channel) setting

The VCR will automatically search for an available channel (21 – 69) to set the video channel for the RF connection.

• Auto clock setting

In an area where a PDC encoded broadcast is received, the VCR clock will be set automatically using the information contained in the PDC signal.

Every Sunday, at 3 AM or 6 AM, the clock setting is adjusted and the summer time/standard time setting is not necessary.

Note on AUTO SETUP

During AUTO SETUP operations, please do not press any of the buttons or controls on the VCR or remote control.

■ With an RF connection – For non EURO-AV connector users

The first steps of the AUTO SETUP should be done with the TV turned off, using the display on the VCR.

1 Press the P/I button to turn the VCR on.

- The initial video channel number (UHF21) is displayed.



- The AUTO SETUP operations will take a few minutes to find the optimum appropriate video channel (between 21 and 69), please be patient.

- The selected optimum video channel number is displayed.

(e.g.)



2 Make a note of the displayed video channel number.

3 Press the OK button.

4 TV setup.



1. Turn on the TV.
2. Set it to the designated video channel (on modern TVs it is normally 0, on older ones 8).
3. Tune its UHF channel to your VCR video channel (e.g. 52) as noted at setp 2.

(e.g. 52... in case of Sanyo's TV)

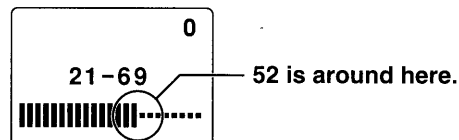

■ **With an AV connection – For EURO-AV connector users**

1 TV setup before proceeding with the AUTO SETUP.



Turn on the TV and set it to AV mode.

2 Press the  button to turn the VCR on.

- This message screen is displayed for 5 seconds.

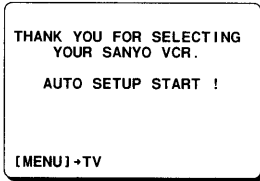

- The AUTO SETUP operations will take a few minutes to find the video channel (between 21 and 69), please be patient.

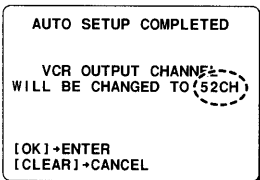

- The displayed video channel (e.g. 52) is for the RF connection.
It is not needed for the AV connection.
Go to step 3.

3 Press the OK button.

Remote control batteries insertion

1. Open the lid.
2. Insert the 2 supplied batteries according to the \oplus and \ominus signs.
3. Replace the lid.

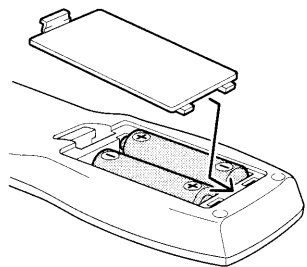

AV connection

After step 2, connect an EURO-AV cable (sold separately) between the VCR and the TV. You can get a higher quality of picture and sound during playback.

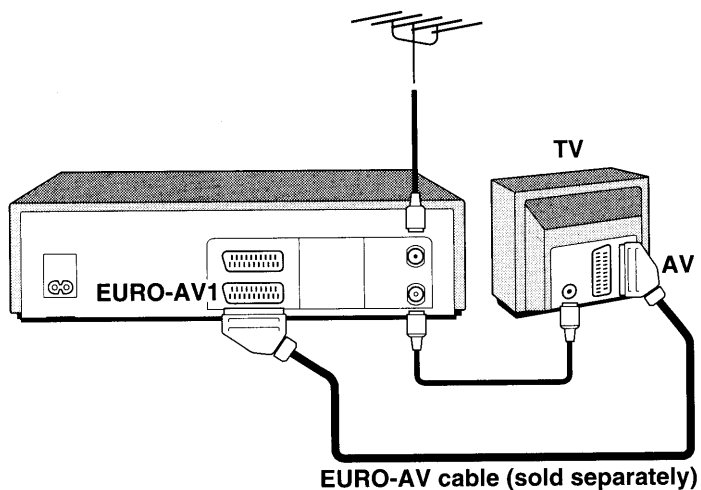

Printed on 100% recycled paper

1AC6P1P1660--
AP2L/E (0198KP-SID)

SANYO

SANYO Electric Co., Ltd.

Printed in Germany

SANYO

INSTRUCTION MANUAL

VHR-288E

Video cassette recorder

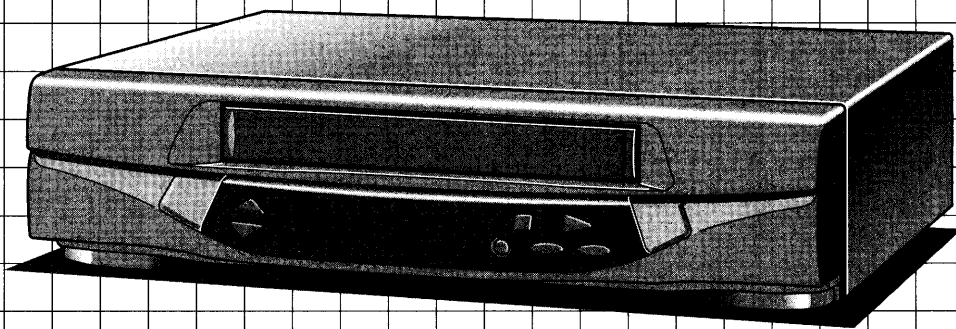

Please read carefully before using the VCR.

VIDEO *Plus+*

VHS
PAL NTSC4.43

	CONTENTS.....	1
1	PRECAUTIONS	2
INTRODUCTION	CONTROLS	3
2	SETUP1 CONNECTIONS	4
PREPARATION	Accessories.....	4
	Remote control batteries insertion.....	4
	SETUP2 AUTO SETUP	6
	ON-SCREEN MENUS AND BASIC CONTROLS	8
	VCR PRESETTING	9
	Manual tuning controls.....	9
	Manual clock adjustment.....	10
	Function setup	10
	Display function	11
3	PLAYBACK.....	12
BASIC OPERATION	Variable playback modes	12
	Index search.....	12
	Counter memory	12
	Endless play	13
	Playback of a NTSC tape.....	13
	Picture adjustments	13
	RECORDING TV PROGRAMMES	14
	Setting the recording type.....	14
	Quick Start Recording timer.....	14
4	VIDEO PLUS+ TIMER RECORDING PROGRAMMING	15
ON-SCREEN OPERATION	On-screen programming.....	15
	Programming on the VCR display.....	16
	ON-SCREEN TIMER RECORDING PROGRAMMING.....	17
	Confirmation/Cancelling.....	17
	PDC function.....	18
	Notes on timer recording	18
	TAPE LIBRARY SYSTEM.....	19
5	TAPE COPY.....	20
ADVANCED OPERATION		
6	TROUBLESHOOTING	21
	SPECIFICATIONS	21
	GUARANTEE TO CUSTOMER	Back cover

Make sure these settings are done before operating the VCR.

PRECAUTIONS

Only cassettes marked **VHS** can be used with this VCR.

Note:

If the unit does not operate properly, switch it off, refer to "TROUBLESHOOTING" (see page 21) or contact your Sanyo authorized service agent.

Safety precautions

DANGER:

This VCR contains live parts. Do not remove the cabinet.

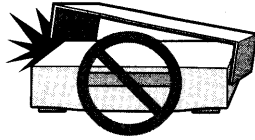

WARNING:

To prevent fire or shock hazard, do not expose this product to rain or moisture.



CAUTION:

Do not put your hand or other objects in the cassette loading slot because of the risk of injury or an accident. Be sure to keep small children away from the VCR.



Caution concerning condensation

Be careful of condensation

Condensation can form inside a VCR when it is suddenly moved from a cold place to a warm, humid one, or when a heater has been turned on to quickly heat the room.

Do not insert a video cassette if you use this VCR in areas subject to condensation.

Wait for 1½ to 2 hours to completely eliminate condensation before using the VCR.

Operating precautions

- Place the VCR on a flat, stable, level surface. Never subject it to violent shaking or any other shock or impact.
- Do not expose the unit to high temperatures. Excessive heat (heat sources such as heaters, ovens, closed car on hot days, etc.) may damage the unit.
- Be sure to use this VCR only in a temperature range of 5°C to 40°C (41°F to 105°F) and at less than 80% humidity.
- Do not use the unit under the following conditions:
 - in locations with high humidity
 - in presence of excessive dirt or dust
 - in areas subject to strong vibrations
 - near strong magnetic fields (e.g. transmitting antennas, motors, fluorescent lights, etc.)
- Do not stack anything on top of your VCR, or block the air vents, to prevent damaging or overheating.
- Do not place anything, except VHS video cassette tapes, in the unit.
- Do not allow rain, steam, dew, salt water, sand, oily smoke, metal objects, etc. to enter the unit.
- Clean with a dry and soft cloth, or soft cloth slightly moistened with a mild detergent solution.
- Do not use any type of solvent, such as alcohol or benzene.

Power on/standby mode

Power is switched on/off by pressing the **⏻/⏻** button.

VCR display

Standby mode (⏻)



Power on mode (I)



"Standby mode" is the condition in which only the time is displayed.

- Do not forget that even in the power off state there is an electrical voltage inside the VCR as long as it is connected to a wall socket.
- Disconnect the mains lead from the wall socket if the VCR is not to be used for a long time.

CONTROLS

1

INTRODUCTION

GB

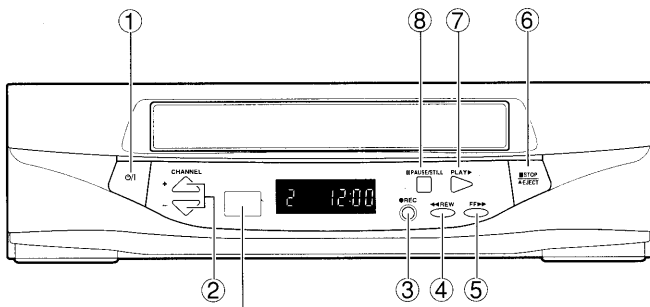

Remote control sensor

Operate the remote control unit within a range of approx. 30° and approx. 6m (20 ft.) from the front of the VCR.

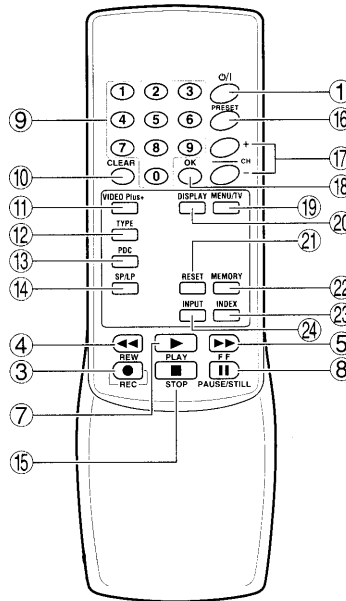

VCR display



Mode	Display
Cassette in	
Playback	
Forward search	
Fast-forward	
Rewind	
Reverse search	
Still picture	
Record	REC
Record pause	REC

(: Flashing)

	Indication	Function	Page
①	⏻/⏻	Power on/standby mode	2
②	CHANNEL+, -	Programme selection, tracking adjustment	13, 14
③	REC	Recording	14, 20
④	REW	Rewind, reverse search during playback	12
⑤	FF	Fast-forward, forward search during playback	12
⑥	STOP/EJECT	Tape stop, cassette ejection (VCR only)	12
⑦	PLAY	Playback	12
⑧	PAUSE/STILL	Pause during recording, still picture during playback	12, 14

(On the remote control only)

⑨	0 - 9	Direct programme selection, for various input	14
⑩	CLEAR	Clears data	17
⑪	VIDEO Plus+	VIDEO Plus+ timer programme set	15, 16
⑫	TYPE	Recording type set	14
⑬	PDC	PDC function on/off	18
⑭	SP/LP	Recording tape speed selection	14
⑮	STOP	Tape stop	12
⑯	PRESET	Tuner preset	9
⑰	CH+, -	Programme selection, tracking adjustment	13, 14
⑱	OK	Data/settings entry	8
⑲	MENU/TV	On-screen operation	8
⑳	DISPLAY	Programme position, day/time display	11
㉑	RESET	Counter reset	12
㉒	MEMORY	Counter "0:00:00" position memory	12
㉓	INDEX	Index search	12
㉔	INPUT	External input mode selection	14, 17, 20

SETUP1 CONNECTIONS

Accessories

Is everything in the box?

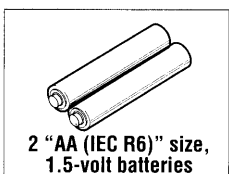
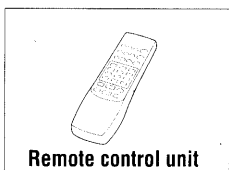
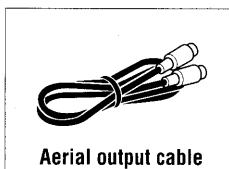
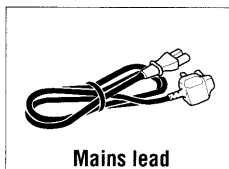

Remote control batteries insertion

- 1 Open the lid.
- 2 Insert 2 "AA (IEC R6)" 1.5 volt batteries (supplied) according to the \oplus and \ominus signs.
- 3 Replace the lid.

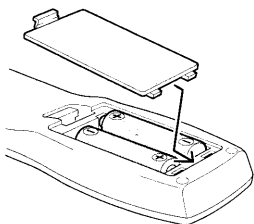

Aerial/RF connection

- 1 Disconnect the aerial cable from your TV, then connect it to the VCR.
- 2 Connect the supplied aerial output cable between the VCR and the TV.

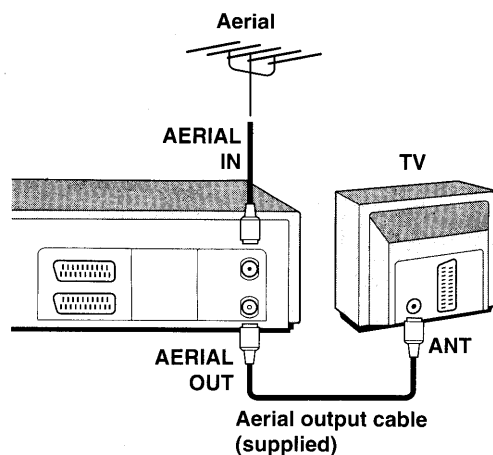

- 3 Connect the mains lead straight and firmly.

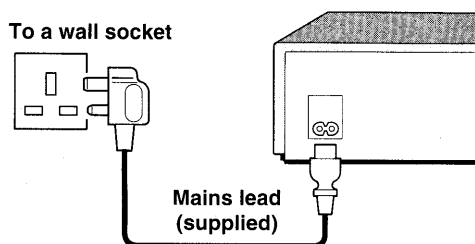

- AUTO SETUP will start if the VCR is switched to the power on mode by pressing the \odot /I button. Go to "SETUP2 AUTO SETUP".

Mains lead connections

- If the plug supplied with this appliance is not suitable for the wall socket in your home, it should be cut off and the correct type fitted.

The wires in the mains lead are coloured according to the following code:

Blue: Neutral **Brown: Live**

If the colours of the wires in the mains lead of this apparatus do not correspond with the colour markings identifying the terminals in your plug, proceed as follows:

- The wire which is coloured blue must be connected to the terminal which is marked with the letter **N** or coloured blue or black.
- The wire which is coloured brown must be connected to the terminal which is marked with the letter **L** or coloured brown or red.
- Do not connect either wire to the **Earth** terminal.

Disposal of plug

If the non rewirable plug is to be cut off, the removed plug should be disposed of carefully as there is a shock hazard should the plug be inserted into a live socket.

Replacing the fuse

The detachable fuse cover must be replaced after changing the fuse.

Only a 3A fuse should be used, it should comply with BS1362, and should carry the ASTA mark

Additional connections

AV connection

After step 2, connect an EURO-AV cable (sold separately) between the VCR and the TV.

- You can get a higher quality of picture and sound during playback.
- When the **PLAY** or **VIDEO Plus+** button is pressed, the TV is automatically switched to the AV mode.

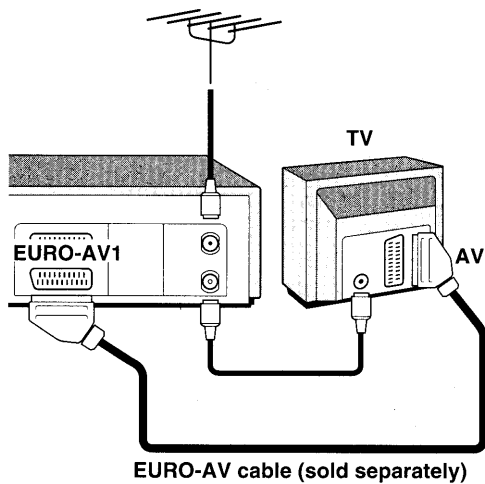

Connecting a satellite receiver

By connecting a satellite receiver to your VCR, you can receive and record satellite broadcasts.

If a satellite receiver is connected at RF and switched on, select SKY1 and the satellite programme will be stored in programme position "6" during AUTO SETUP (see page 6).

For detailed information, please refer to the instruction manual accompanying your satellite receiver.

Note:

The **EURO-AV2** terminal is used for signal input only.

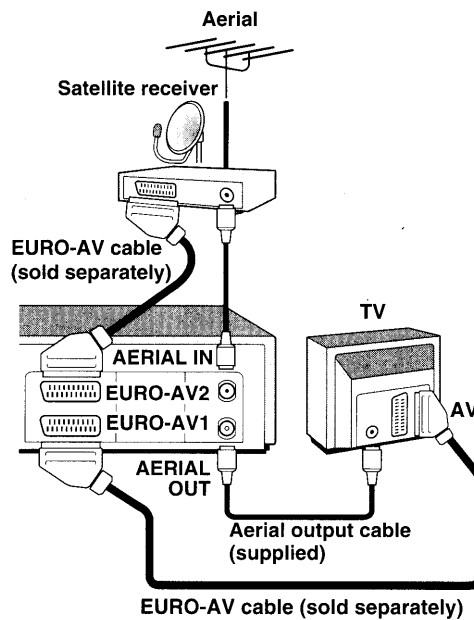

SETUP2 AUTO SETUP

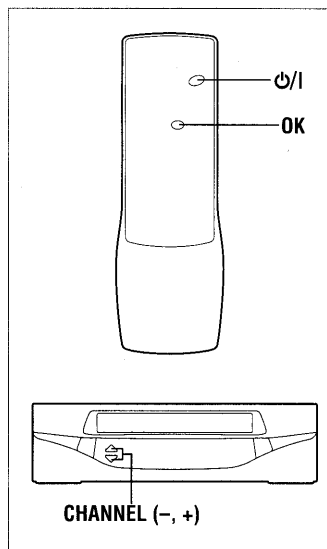

*1

For areas where there is a satellite broadcasting service, the TV station with the lowest frequency will be preset to this programme position number. (Select SKY 1 on the cable box.)

*SKY 1

During AUTO SETUP and when the satellite receiver is connected at RF, ensure the satellite receiver is switched on and SKY 1 selected. The satellite programme will be stored in programme position "6".

This VCR is equipped with an AUTO SETUP function. The necessary settings are entered automatically before the VCR is used for the first time.

The AUTO SETUP function will do the following.

Auto tuning

The VCR will automatically search and preset all the available TV stations in the area of use to programme position numbers (1 to 44).

Auto sorting the TV stations

The TV stations available in your area will be automatically preset in order starting from programme position "1" to programme position "6", as follows.

Programme position	"1"	"2"	"3"	"4"	"5"	"6"
TV station	BBC1	BBC2	ITV	C4	CH5	*1 or *SKY1

Auto video channel (RF output channel) setting

The VCR will automatically search for an available channel (21 – 69) to set the video channel for the RF connection.

Auto clock setting

The VCR clock will be set automatically using the information contained in the PDC signal.

Every Sunday, at 3 AM or 6 AM, the clock setting is adjusted and the summer time/standard time setting is not necessary.

Notes on AUTO SETUP:

- During AUTO SETUP operations, please do not press any of the buttons or controls on the VCR or remote control.
- AUTO SETUP is not possible if the VCR is set to external input mode.
- The skip function will be automatically set for all position numbers where no TV station has been preset.
- Due to possible changes by broadcasters, TV stations may not always be sorted in the correct order (e.g. BBC1 may be set to programme position 7 or higher).

With an AV connection – For EURO-AV connector users

1 TV setup.



Turn on the TV and set it to AV mode.

2 Press the P/S button to turn the VCR on.

- This message screen is displayed for about 5 seconds.

If not, press both **CHANNEL** (– and +) buttons on the VCR for at least 3 seconds.

(TV screen)

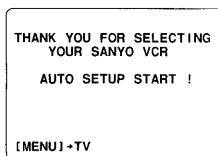

- The AUTO SETUP operations will take a few minutes, please be patient.

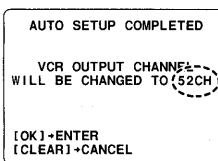

- The displayed video channel (e.g. 52) is for the RF connection. It is not needed for the AV connection. Go to step 3.

3 Press the OK button.

With an RF connection – For non EURO-AV connector users

The first steps of the AUTO SETUP should be done with the TV turned off, using the display on the VCR.

1 Press the \odot/I button to turn the VCR on.

- The initial video channel number (UHF 21) is displayed.

If not, press both **CHANNEL** (- and +) button on the VCR for at least 3 seconds.



- The AUTO SETUP operations will take a few minutes to find the optimum appropriate video channel (between 21 and 69), please be patient.



- The selected optimum video channel number is displayed.

(e.g.)



2 Make a note of the displayed video channel number.

3 Press the OK button.

4 TV setup.



1. Turn on the TV.
2. Set it to the designated video channel (on modern TVs it is normally 0, on older ones 8).
3. Tune its UHF channel to your VCR video channel (e.g. 52) as noted at step 2.

(e.g. 52...in case of Sanyo's TV)

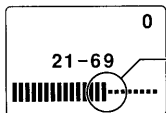

Note:

If channel position 0 or 8 on your TV is preset to a TV station, select another channel position where no TV station is received.

(For more details, please refer to your TV instruction manual.)

ALTERNATIVE METHODS

If it is difficult to tune on your TV, the UHF channel for the video channel, instead of step 4, follow one of the methods below.

Using the test pattern

- 1 Press the \odot/I button to turn the VCR off.
- 2 Press and hold the **PRESET** button for at least 3 seconds.
 - The video channel number (e.g. 52) is displayed.



- 3 Turn on the TV and set it to the designated video channel 0 or 8.
- 4 Turn the TV's UHF channel to the selected video channel number (e.g. 52).
 - The test pattern (below) appears when the video channel is tuned.

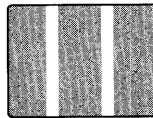

- 5 When finished, press the **PRESET** button.
 - The VCR is turned off.

Using a playback picture

- 1 Playback a tape.
- 2 Turn on the TV and set it to the designated video channel 0 or 8.
- 3 Tune the TV's UHF channel to the selected video channel number (e.g. 52).
 - The playback picture appears when the video channel is tuned.



- 4 When finished, stop the tape.

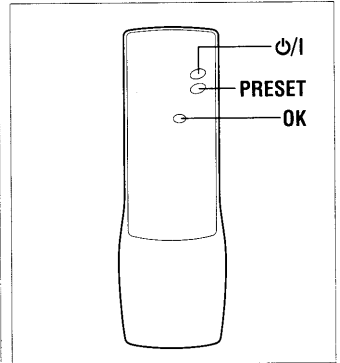

With an RF connection, on-screen AUTO SETUP

- 1 Turn on the TV and set it to the designated video channel 0 or 8.
- 2 Tune the TV UHF channel to the initial video channel number (21).
 - The on-screen display will not be possible if the video channel receives any TV station. Please do the AUTO SETUP using the display on the VCR.
- 3 Go to step 2 under "**With an AV connection**" on page 5.
 - If the video channel is changed, tune the TV UHF channel to the displayed video channel number after pressing the **OK** button.

ON-SCREEN MENUS AND BASIC CONTROLS

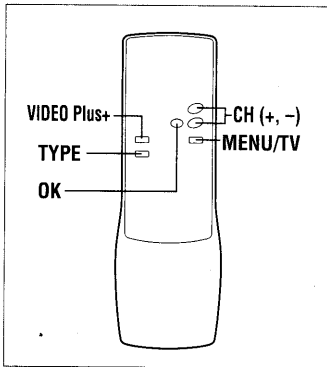

The VCR can easily be programmed by using the menu displayed on-screen.

The menus are controlled from the remote control.

If you memorize the basic operations, each setting can easily be made by following the steps of the concerned menu.

Turn on the TV, then set it to the preset video channel or AV mode (if using the "AV connection").

Multicoloured on-screen display

For easier viewing, the menu colours have the following appearance.

- If a wrong sub-menu has been selected, press the **MENU/TV** button and start again.

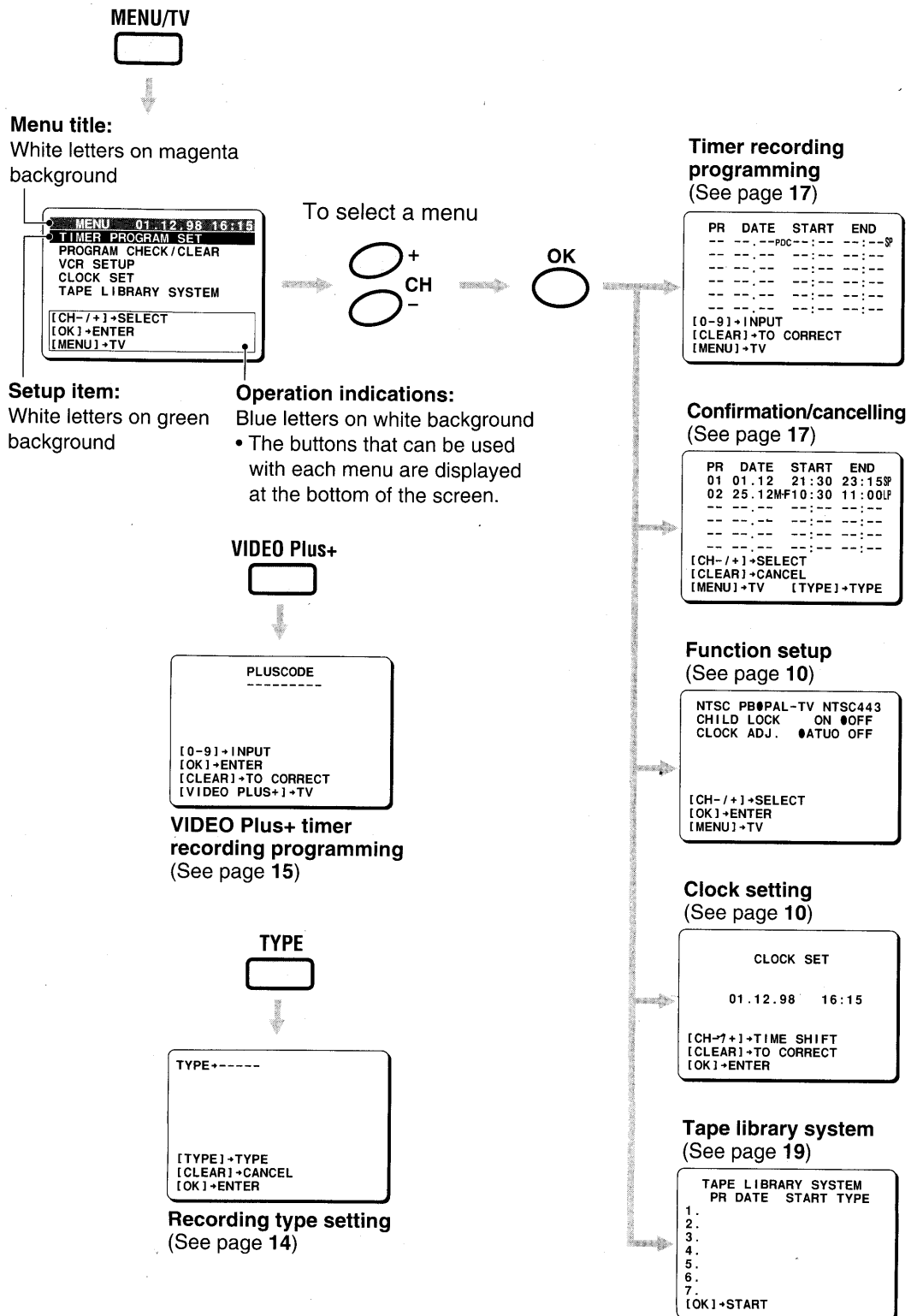

 Turn on the TV, then set it to the video channel or AV mode (if using AV connection).

Manual tuning controls

Sorting the TV stations

It is possible to sort the TV stations as desired.

Example: To change BBC1 from programme position "7" to programme position "1".

Programme position	"1"	"2"	"7"	
(Before)	(A)	BBC2	BBC1	
TV station	(After)	BBC1	BBC2	(A)

- 1 Press the **PRESET** button.
- 2 Using the **CH (+ or -)** button select the TV station for sorting (e.g. BBC1, selected programme position "07").



- 3 Using the numeric buttons (**0 - 9**), enter the target programme position number (e.g. "01", enter **01**).

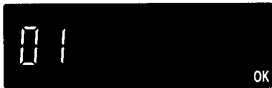

- 4 Press the **OK** button.
 - The VCR will interchange the locations of BBC1 and (A).
- To sort another TV station, repeat steps 2 to 4.
- 5 When finished, press the **PRESET** button.

Fine tuning

If the tuning is not optimum, it can be improved by manual fine tuning.

- 1 Press the **PRESET** button.
- 2 Press the **FF** or **REW** button to obtain the best possible picture and sound.
- 3 Press the **OK** button.
- 4 When finished, press the **PRESET** button.

Skip function

If only programme position numbers 1 to 30 have been preset, you can set the skip function for programme position numbers 31 to 44, so that only the preset TV stations will appear when pressing the **CH (+ or -)** button.

- 1 Press the **PRESET** button.
- 2 Using the numeric buttons or the **CH (+ or -)** button, select the programme position number to skip.
- 3 Press the **CLEAR** button.
 - The "S" indicator will light.

To cancel the skip function, press the **CLEAR** button again to erase the "S" indicator.

- 4 Press the **OK** button.
- Repeat steps 2 to 4 for every programme position number to skip.

- 5 When finished, press the **PRESET** button.

Manual tuning

This tuning mode can be used to modify the settings entered by the Auto tuning function, or to manually preset the TV stations to particular programme position numbers.

- 1 Press the **PRESET** button.
- 2 Using the **CH (+ or -)** button, select the desired programme position number.
- 3 Press the **PLAY** button.

If the search stops on a broadcast other than the one desired, press the **PLAY** button again until the broadcast from the desired TV station appears on the TV screen.
- 4 Press the **OK** button when the desired TV station appears on the TV screen.

Repeat steps 2 to 4 to preset another TV station to another programme position number.
- 5 When finished, press the **PRESET** button.

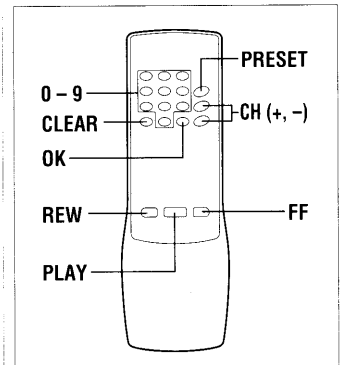

VCR PRESETTING

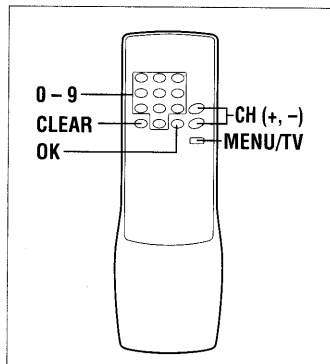

Manual clock adjustment

- 1 Press the **MENU/TV** button, then select the **CLOCK SET** using the **CH (+ or -)** button.

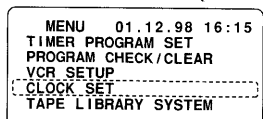

- 2 Press the **OK** button.

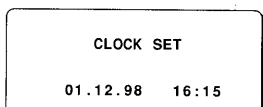

- 3 Continue pressing the **CLEAR** button to delete the incorrect numbers, then enter the new settings using the numeric buttons.

Summer/Standard time setting

Each press of the **CH (+ or -)** button will advance or retard the clock by 1 hour.

- 4 When finished, press the **OK** button.
 - Seconds will start counting from "00" as the **OK** button is pressed.
 - The normal TV broadcast screen will return.

Power interruption

If the power to the VCR has failed or has been disconnected for more than 1 hour, the date, time, function setup memory and any recording information regarding future recordings should be reset.

However, the Auto clock setting function will reset the date and time when the power is restored to the unit.

The tuner preset memory will not be erased. So there is no need to retune the VCR stations.

Function setup

- 1 Press the **MENU/TV** button, then press the **CH (+ or -)** button to select the **VCR SETUP**.

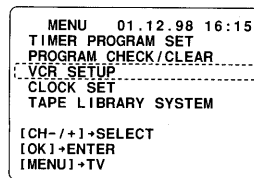

- 2 Press the **OK** button.

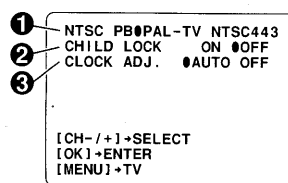

- 3 Press the **CH (+ or -)** button to select the desired item to set (1 - 3).

1 NTSC playback system

PAL TV: When using a PAL (I) system TV.

NTSC443: When using an NTSC4.43 system TV. (Please use the EURO-AV terminal.)

2 Child lock function

ON: "BLOCKED" is displayed on the TV screen and the sound is muted.

OFF: The child lock function is not engaged.

3 Clock adjustment

AUTO: The clock is automatically adjusted every Sunday at 3 AM or 6 AM.

OFF: The clock is not adjusted automatically.

- 4 Press the **OK** button to set the desired mode.

- Every time the **OK** button is pressed, the symbol "●" will move from one setting to the next.

To set a mode, make sure the "●" is displayed to the left of the desired setting.

- 5 When finished, press the **MENU/TV** button.

Display function

When pressing the buttons shown in the table below, each mode can be seen displayed on the TV screen for about 2 seconds.

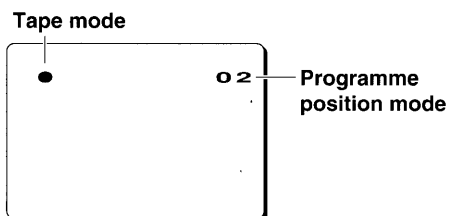

By pressing the **DISPLAY** button, the programme position number and current day/time can be seen displayed.

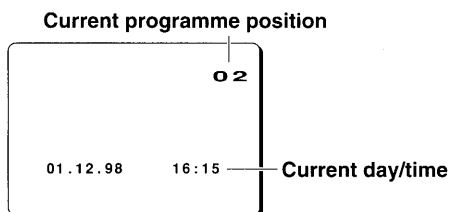

To cancel the function display, press the **DISPLAY** button one more time.

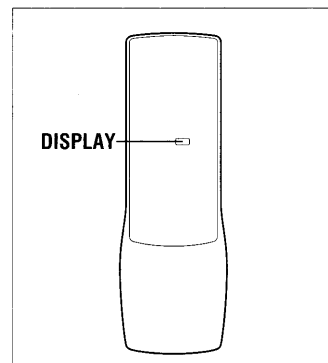

Tape mode

Press....	Mode	Display
PLAY	Playback	▶
FF	Fast-forward	▶▶
REW	Rewind	◀◀
REC	Recording	● 02
PAUSE/STILL in recording mode	Recording pause	● 02

Programme position mode

Press....	Mode	Display
CH (+ or -) Numeric (0 - 9)	Programme position number	01 - 44
INPUT	External input (EURO-AV1)	L1
	External input (EURO-AV2)	L2

PLAYBACK

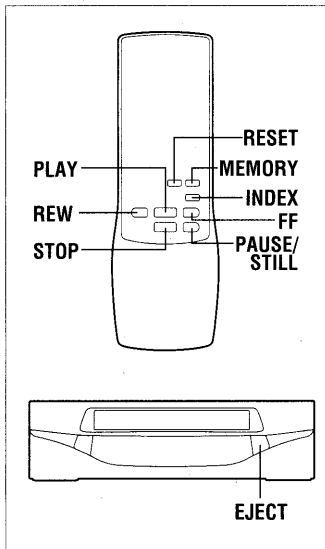

Auto power on

The power is automatically switched on as a cassette is inserted while the VCR is in the standby mode.

Auto play

The VCR will play back a tape automatically when a video cassette is inserted whose erasure-prevention tab has been removed.

Auto eject

When a video cassette without an erasure-prevention tab is played to the end of the tape, the tape will be automatically rewound and then the cassette will be ejected.

Power off eject

The video cassette will be ejected when the **EJECT** button is pressed, even when the VCR is in standby mode.

Turn on the TV, then set it to the preset video channel.

1 Insert a recorded video cassette.

Cassette loading

Gently push the centre of the cassette until it is loaded automatically.



2 Press the **PLAY** button.

Stop

Press the **STOP** button.

Eject the cassette

Press the **EJECT** button on the VCR.

Rewind

Press the **REW** button during stop or play for reverse search operation.

Fast-forward

Press the **FF** button during stop or play for forward search operation.

Variable playback modes

Forward search

Press the **FF** button during playback or fast-forward operation.

Reverse search

Press the **REW** button during playback or rewind operation.

Still picture

Press the **PAUSE/STILL** button during normal playback.

Frame advance

Press the **PAUSE/STILL** button during still picture.

Index search

An index signal is automatically placed at the beginning of each recording made on this VCR. This index can be used to search for the next (or present) recording.

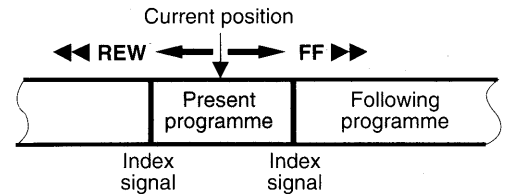

Notes:

- Make sure that indexes are at least five minutes apart from each other.
- Index signals are not recorded after a recording pause.

1 Press the **INDEX** button while in the stop or playback mode.

To cancel the index search mode, press the **INDEX** button again.

2 Press the **FF** or **REW** button.

To stop the search function, press the **STOP** button.

- Playback will start automatically when an index is found.



Counter memory

This convenient feature for finding the beginning of a specific recording etc., is made possible by the "Linear Time counter" that indicates the tape run time in hours, minutes and seconds.

1 Press the **RESET** then the **MEMORY** button before starting recording or playback.

- The zero point of the counter is now memorized and the memory indicator "M" will illuminate.

2 Press the **REW** button at the end of the recording or playback, the tape will be rewound and stop automatically at the memorized position.

Notes:

- Whenever you load a cassette tape, the counter is reset to "0:00:00".
- If you play back a blank tape or a blank portion of tape, the counter will not operate.

Endless play

This function will play back a tape to the end, rewind it then replay it again, and again until you stop it.

- 1 In the stop or playback mode, first press the **PLAY** button then while holding it down press the **REW** button on the VCR.
- 2 To cancel the endless play, press the **STOP** button.
 - If the counter memory function is used in combination with endless play, the VCR will play back the tape to the counter reading "**M 0:00:00**" then start again from the beginning.

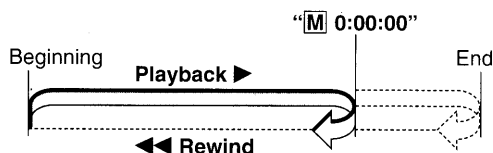

Note:

During endless play, please do not press **FF**, **REW** or **PAUSE/STILL** button because the endless play will be cancelled.

Playback of a NTSC tape

This VCR can playback a NTSC tape on a PAL (I) or NTSC 4.43 system TV.

For NTSC playback system setting, refer to "**Function setup**" on page 10.

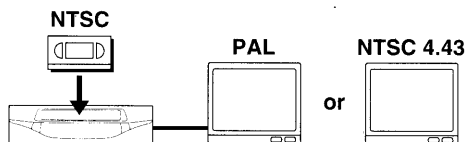

When you playback a NTSC tape on a PAL TV,

- If the image is unstable, rolling vertically, use the TV vertical hold button to stabilize the image.
- The image may shrink vertically and a black band may appear at the top and bottom of the screen.

Notes about NTSC tape

- A NTSC tape cannot be copied normally.
- Picture quality of NTSC tapes cannot be guaranteed with this VCR.

Picture adjustments

Tracking adjustment

This VCR is equipped with an auto tracking function. During playback this function will adjust the tracking to the best possible image. If noise appears in the playback picture, press the **CH (+ or -)** button, to reduce the noise interference in the image.

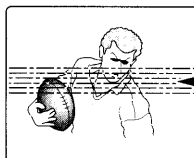

Noise interference

Note:

Depending on the quality of the cassette tape, you may find that some noise interference cannot be completely corrected using the tracking controls.

If the still picture moves up and down

Use the **CH (+ or -)** button, to correct.

Once the cassette tape is unloaded, the VCR is reset and the next time the VCR is used you may need to do the corrections again.



Notes:

- During variable playback modes the picture may contain some noise or vibration that cannot be corrected. This is not a malfunction.
- If still picture playback is continued for about five minutes, the VCR will automatically change to stop mode in order to prevent the tape from being damaged.
- This VCR will not guarantee the variable playback modes picture quality.

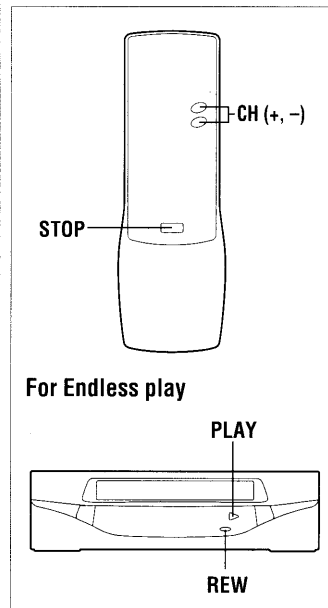

For Endless play

RECORDING TV PROGRAMMES

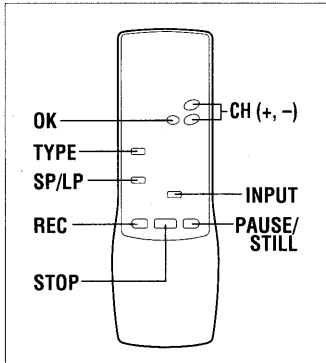

To record from an external source

At step 1,

Press the **INPUT** button.

"L1" or "L2" is displayed instead of the programme position number.

"L1": EURO-AV1

"L2": EURO-AV2

Tape speed

SP	Best image and sound quality. No display.
LP	Recording or playback times are double the SP mode.
EP	NTSC playback only

Mis-erasure prevention eject

The cassette will automatically be ejected if recording is attempted on a video cassette without an erasure-prevention tab.

Auto rewind

The VCR automatically rewinds the tape when it reaches the end. This function does not operate with timer recording or Quick Start Recording timer.

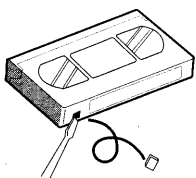

Erasure-prevention tab

To prevent accidental erasure, remove the tab after recording. To record again, cover the hole with vinyl tape.

Turn on the TV, then set it to the preset video channel or AV mode (if connected by a EURO-AV cable).

Insert a video cassette with erasure-prevention tab.

1 Press the numeric buttons, or the **CH (+ or -)** button, to select the TV station to be recorded.

2 To select the tape speed, press the **SP/LP** button.

3 If necessary, press the **TYPE** button to set the recording type. Please refer to "Setting the recording type" below.

4 Press the **REC** button.

5 To stop the recording, press the **STOP** button.

Setting the recording type

If a recording type is selected, it will be displayed and make programme selection easier when listing the tape recordings data. It can be used to easily find a desired recording. (Refer to "TAPE LIBRARY SYSTEM" on page 19.)

1 Press the **TYPE** button repeatedly until the desired type is displayed.

2 When the desired type has been selected, press the **OK** button.

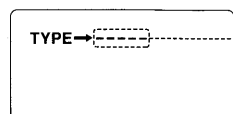

(Tape library system)

PR	DATE	START	TYPE
1.	02 25.12	18:00	SPORT
2.	08 25.12	20:00	MUSIC
3.	12 26.12	14:00	NEWS
4.	02 26.12	18:00	FILM
5.			
6.			
7.			

[1-7]•SELECT

- FILM (F): Film
- ↓
- SPORT (S): Sports
- ↓
- DRAMA (d): Drama
- ↓
- MUSIC (M): Music
- ↓
- NEWS (n): News
- ↓
- ANIMA (A): Animation, cartoon
- ↓
- EDUC. (E): Educational programme
- ↓
- GAME (g): Game
- ↓
- THRIL (t): Thriller
- ↓
- COMED (c): Comedy

The letter in brackets (e.g. (F)) shows the display on the VCR display.

Note:

The selected recording type is cancelled if the VCR is turned off (standby mode) or if the cassette tape is ejected.

If you wish to avoid recording unwanted material

1 Press the **PAUSE/STILL** button.

2 To continue recording, press the **PAUSE/STILL** button or **REC** button.

Note:

If the record pause mode continues for about five minutes, the VCR will automatically go into the stop mode in order to prevent damage to the tape.

Recording one programme while watching another

1 Start recording the desired TV station programme selected on the VCR.

2 Select on the TV receiver the TV station you want to watch. If using the "AV connection", set the TV to the TV mode.

Quick Start Recording timer

Timer recording is simple.

You can start a recording and then programme when the VCR will automatically stop recording and go into standby mode.

1 Press the **REC** button twice.

2 Set the recording end time by using **REC** and **CH (+ or -)** buttons.

REC: Units of 30 minutes

CH+, CH-: Units of 1 minute

- The timer indicator () will light after the recording end time is set.



To stop the recording at any time, press the **STOP** button.

Checking/Changing

When the **REC** button is pressed during Quick Start Recording, the recording end time will blink.

The recording end time can be changed by pressing **REC** and **CH (+ or -)** buttons.

VIDEO PLUS+ TIMER RECORDING PROGRAMMING

4

ON-SCREEN OPERATION

GB

There are two ways of programming VIDEO Plus+ timer recordings.

One is using the on-screen display and the other one is using the VCR display.

- You can set up to 6 programmes to be recorded upon a period of up to 1 year.

On-screen programming

Turn on the TV, then set it to the preset video channel.

- Press the **VIDEO Plus+** button.

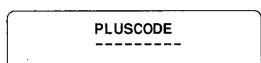

- Using the numeric buttons, enter the PlusCode number for the programme you want to record. (e.g. **489135**)

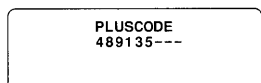

If you entered a wrong number, press the **CLEAR** button to delete it, then enter the correct number.

- Press the **OK** button.

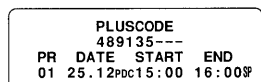

If the programme position number (PR) displays "--"

Enter the programme position number the TV station has been preset to.

- That setting will be memorized and set the next time the same TV station is selected.

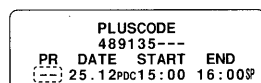

- When all the settings are as desired, press the **OK** button.

You can programme another recording by repeating steps 2 to 4.

- Insert a video cassette with erasure-prevention tab. Make sure the tape is longer than the total recording time.

- Press the **VIDEO Plus+** button.
 - The timer indicator (□) will light on the VCR display and the VCR goes into timer recording standby mode.

Additional settings

After pressing the **OK** button in step 3.

Recording tape speed setting

Press the **SP/LP** button repeatedly to display the desired tape speed.

Daily/Weekly recording

Press the **MENU/TV** button repeatedly to display the desired recording mode.

M-F: for daily recording (Monday through Friday)

WK: for weekly recording (the same programme every week)

Setting the recording type

Press the **TYPE** button repeatedly until the desired type is displayed.

Changing the end time

Each press of the **CH (+ or -)** button will change the recording end time by units of 10 minutes.

PDC function

Press the **PDC** button repeatedly.

- When the "PDC" indicator appears, the PDC function is set. (See page 18 for more information on PDC.)

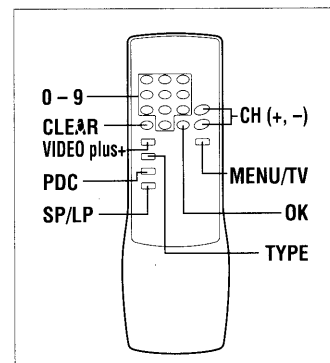

This VCR has a built-in VIDEO Plus+ system. Programming timer recordings is now as simple as entering a PlusCode number (1 to 9 digits) listed next to each programme in your local TV guide or newspaper TV programme listing.

VIDEO Plus+ and **PlusCode** are trademarks of Gemstar Development Corp. **VIDEO Plus+** system is manufactured under license from Gemstar Development Corporation.

Newspaper or TV guide

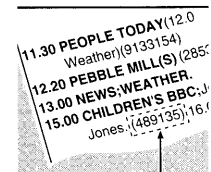

PlusCode

Easy process

- Press the **VIDEO Plus+** button.



- Enter the **PlusCode** number.



- Press the **OK** button.

Additional settings



- Press the **OK** button.



- Press the **VIDEO Plus+** button.

VIDEO PLUS+ TIMER RECORDING PROGRAMMING

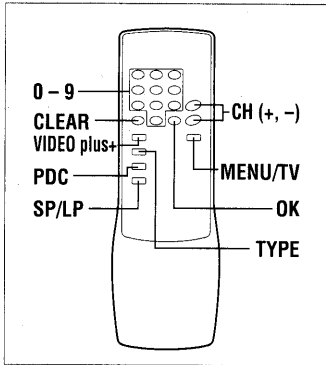

Programming on the VCR display

You can programme a VIDEO Plus+ timer recording on the VCR display even if the TV is turned off.

- 1 Press the **VIDEO Plus+** button.



- 2 Using the numeric buttons, enter the Plus Code number for the programme you want to record. (e.g. **489135**)



If you entered a wrong number, press the **CLEAR** button to delete it, then enter the correct number.

- 3 Press the **OK** button.



Note:

If the programme position number (PR) displays "--", please refer to page 15.

- 4 When all the settings are as desired, press the **OK** button.

You can programme another recording by repeating steps 2 to 4.

- Insert a video cassette with erasure-prevention tab. Make sure the tape is longer than the total recording time.

- 5 Press the **VIDEO Plus+** button.
 - The timer indicator (☐) will light on the VCR display and the VCR goes into timer recording standby mode.

Additional settings

After pressing the **OK** button in step 3.

Recording tape speed setting

Press the **SP/LP** button repeatedly to display the desired tape speed.

Daily/Weekly recording

Press the **MENU/TV** button repeatedly to display the desired recording mode.

M-F: for daily recording (Monday through Friday)

WK: for weekly recording (the same programme every week)

Setting the recording type

Press the **TYPE** button repeatedly until the desired type is displayed.

Changing the off time

Each press of the **CH (+ or -)** button will change the recording off time by units of 10 minutes.

PDC function

Press the **PDC** button repeatedly.

- When the "PDC" indicator appears, the PDC function is set. (See page 18 for more information on PDC.)

ON-SCREEN TIMER RECORDING PROGRAMMING

4

ON-SCREEN OPERATION

GB

Example: Programme position... 02
Date... 25 December
Start time... 21:30
End time... 23:15

Turn on the TV then set it to the preset video channel or AV mode (if connected by a EURO-AV cable).

1 Press the **MENU/TV** button, then press the **CH (+ or -)** button to select the **TIMER PROGRAM SET**.

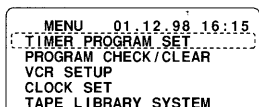

2 Press the **OK** button.

3 Using the numeric buttons, set the programme position number (e.g. 02).

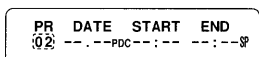

Recording tape speed setting

Press the **SP/LP** button repeatedly to display the desired tape speed.

4 Using the numeric buttons, set the date (e.g. 25 12).

If you entered a wrong number, press the **CLEAR** button to delete it, then enter the correct number.

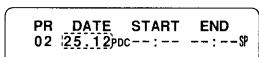

Daily/Weekly recording

Press the **CH+** button repeatedly to display the desired recording mode.

M-F: for daily recording (Monday through Friday)

WK: for weekly recording (the same programme every week)

PDC function

Press the **PDC** button repeatedly.

- When the "PDC" indicator appears, the PDC function is set. (See page 18 for more information on PDC.)

5 Set the recording start and end times (e.g. 21 30 23 15).

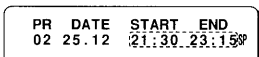

Setting the recording type

Press the **TYPE** button repeatedly until the desired type is displayed.

6 When all the settings are as desired, press the **OK** button.

You can programme another recording by repeating steps 3 to 6.

- Insert a video cassette with erasure-prevention tab. Make sure the tape is longer than the total recording time.

7 Press the **⏻/I** button.

- The timer indicator (⏻) will light on the VCR display and the VCR goes into timer recording standby mode.

Confirmation/Cancelling

1 Press the **MENU/TV** button, then press the **CH (+ or -)** button to select the **PROGRAM CHECK/CLEAR**.

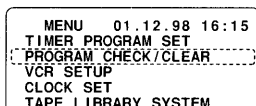

2 Press the **OK** button.

- Programmed timer recordings are listed.

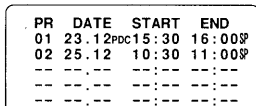

Recording type confirmation

Press the **TYPE** button and the "TYPE" column will be displayed instead of the "END" time column.

Press the **TYPE** button again to return to the "END" time column display.

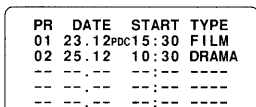

- To correct a programmed timer recording, first cancel it, then reprogramme it as desired.
- To cancel a programmed timer recording, continue with step 3.
- To return to the normal TV broadcast screen, press the **MENU/TV** button.

3 Using the **CH (+ or -)** button, select the programme to cancel.

4 Press the **CLEAR** button.

5 When finished, press the **MENU/TV** button.

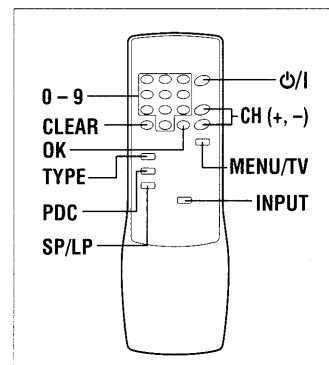

To record from an external source

At step 3,

Press the **INPUT** button to select the terminal used.

"L1" or "L2" is displayed instead of the programme position number.

"L1": EURO-AV1

"L2": EURO-AV2

If a programme position number is already displayed, first press the **CLEAR** button.

Ensure the external source e.g. satellite receiver is switched on and the correct programme has been selected.

ON-SCREEN TIMER RECORDING PROGRAMMING

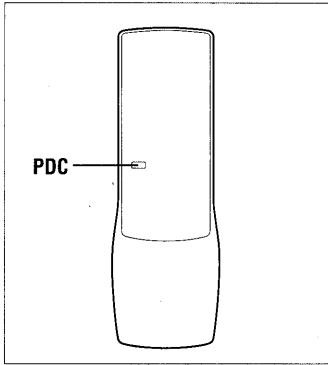

PDC function

The PDC function ensures that the recording is made according to the recording on and off time control signals broadcasted by the TV station. Therefore, if the recording start (on) and/or end (off) time are changed, the VCR is informed of the altered times and recording is changed, whether it is at an earlier or later time.

Also, if the programme being recorded is interrupted (for example by a news special, etc.) and the PDC function is on, recording will be automatically interrupted and will automatically resume when the programme starts again.

Notes:

- Set the recording times and date exactly as advertised. If the start (on) time is different from advertised, the PDC function will not work.
- Not all TV stations transmit PDC signals. Check in your region to find out which stations transmit PDC signals.
- If the station does not transmit PDC signals or if the PDC function is not set, the recording will be done at the programmed times.

PDC standby period

When programming with the PDC function, the recording can be done anytime in the standby period if the start (on) time differs from the scheduled one.

The PDC standby period is from 20:00 (the previous day) to 4:00 (the following day).

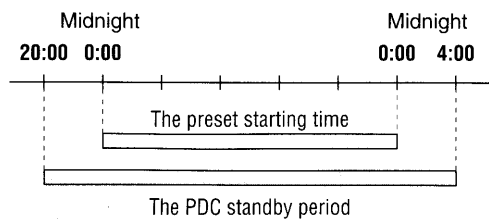

Notes on timer recording

- The (⏏) indicator will flash if no video cassette is loaded when going into timer standby mode.
- The (⏏) indicator will flash and the video cassette is ejected if a video cassette with no erasure-prevention tab is loaded.
- Daily recording starting on a Saturday or Sunday is not possible.
- Daily or weekly recording using the PDC function is not possible.
- Even if a timer recording has been preset, the VCR can be used as usual up to the programmed start time. When finished using the VCR, do not forget to return it to timer recording standby mode.

Programme priority

- If several timer recordings have overlapping recording time, the recording with the earliest start time will be recorded first, until the end.
- Recordings programmed with PDC always have priority.
- If two PDC-programmed recordings overlap, the recording that starts first will have priority.

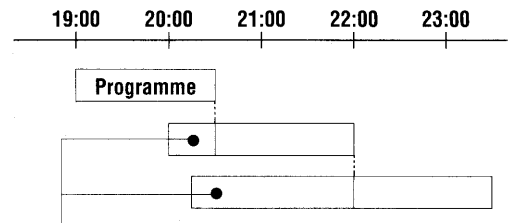

These portions will not be recorded

TAPE LIBRARY SYSTEM

This function will list the tape recordings data (Programme position number, date, recording start time, type). It can be used to easily find a desired recording.

The recording type is only displayed if it has been set before recording the programme.

Insert a cassette tape recorded on this VCR.

1 Press the **MENU/TV** button, then press the **CH (+ or -)** button to select TAPE LIBRARY SYSTEM.

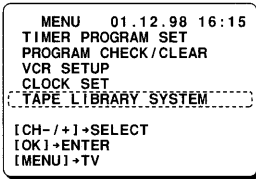

2 Press the **OK** button.

- If the tape recordings data has already been read, it will be displayed.

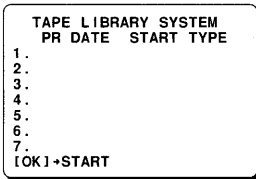

3 Press the **OK** button one more time.

- The tape is rewound to the beginning and the recordings data is read. Every time a set of recording data is read it is displayed on-screen.
- Up to 7 sets of recording data can be displayed on-screen at the same time. If 8 or more sets of recording data are read, the last 7 sets only are displayed.

To cancel the operation, press the **STOP** button.

4 When the data for the desired recording is displayed, press the corresponding numeric button (**1 - 7**).

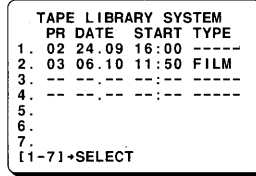

- This message will be flashing on-screen while the tape is rewound to the beginning of the desired recording. Playback will then start automatically.



Notes:

- This function can only be used with tapes recorded by this VCR.
- If a recording data cannot be read, "--" will be displayed.
- If a type has not been selected before recording, "-----" will be displayed.
- Recording data of recordings shorter than 5 minutes may not be displayed.
- If the tape is unloaded or rerecorded, the data will be cancelled.
- If more than one search is made, starting with the second search, the tape will be completely rewound before it is fast-forwarded to the desired recording.

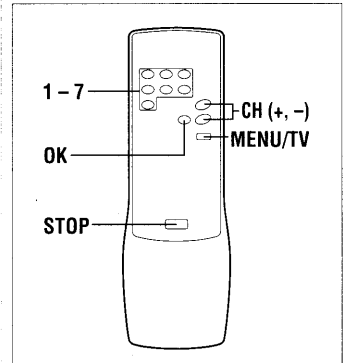

TAPE COPY

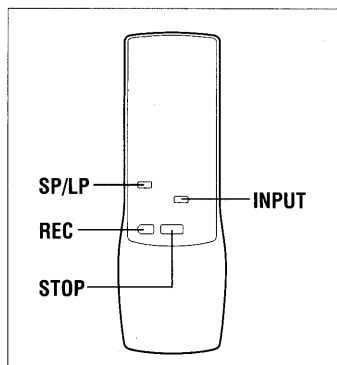
**CAUTION:**

The unauthorized recording of television programmes, video tapes, films and other such material may infringe upon copyright or the rights of third parties.

Copying (dubbing) a tape can be done using two video recorders, a playback VCR (e.g. a camcorder) and a recording VCR.

RECORDING VCR

- Insert a video cassette with erasure-prevention tab.

1 Press the **INPUT** button to select the terminal used.

- "L1" or "L2" is displayed instead of the programme position number.

EURO-AV1: select "L1"

EURO-AV2: select "L2"



2 To select the tape speed, press the **SP/LP** button.

PLAYBACK VCR (Camcorder)

- Insert the recorded video cassette.

3 Start playback.

RECORDING VCR

4 When the desired starting position is reached, press the **REC** button to record.

5 When finished, press the **STOP** button on both VCRs.

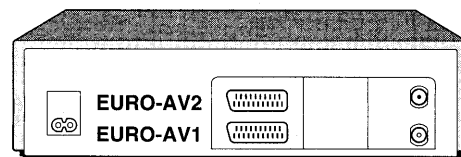
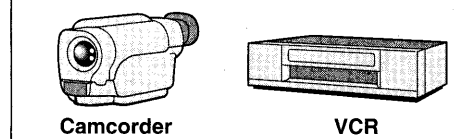
Recording VCR**Playback VCR (Camcorder)**

TROUBLESHOOTING

6

GB

Symptom	Check points
POWER TROUBLE	
No power	<ul style="list-style-type: none"> The mains lead is disconnected.
The remote control unit doesn't operate	<ul style="list-style-type: none"> The batteries are low.
RECEIVER TROUBLE	
No TV programmes received	<ul style="list-style-type: none"> Are the connections between your VCR and TV correct? Was tuning correctly preset?
Reception is poor when TV is on video channel	<ul style="list-style-type: none"> The video channel setting of the TV does not correspond to the video channel presetting of the VCR.
PLAYBACK TROUBLE	
Playback picture does not appear	<ul style="list-style-type: none"> The video channel setting of the TV does not correspond to the video channel presetting of the VCR.
Interference in playback picture	<ul style="list-style-type: none"> Adjust the tracking control. Dust or dirt on video heads. Contact your Sanyo authorized service agent.
RECORDING TROUBLE	
No recording	<ul style="list-style-type: none"> The erasure-prevention tab on the cassette has been removed.
VIDEO Plus+ or timer recording is not possible	<ul style="list-style-type: none"> The starting day and time have not been set correctly. The clock day and time are not set correctly. There has been a power interruption of more than one hour.

Repairs

This VCR is a precision instrument and, if treated with care, will provide years of satisfactory performance. However, in the event of difficulty, the owner is advised not to attempt to make repairs or open the cabinet. Servicing should always be referred to your Sanyo authorized service agent.

SPECIFICATIONS

6

General

Video format:	VHS PAL/NTSC 4.43
Television system:	CCIR: 625 lines, PAL colour signals
TV channel storage capacity:	44 positions
Video heads:	2 heads
Tape speed:	<ul style="list-style-type: none"> PAL NTSC (Playback only) SP: 23.39 mm/sec SP: 33.35 mm/sec LP: 11.70 mm/sec LP: 16.67 mm/sec EP: 11.12 mm/sec
RF converter:	Built-in UHF converter
Converter output:	On channel 21 - 69
Timer indication:	24-hour indication
Power failure backup:	Approx. one hour
Timer recording:	1 year 6 programmes with daily (Monday through Friday) and weekly recording function
Power requirement:	220-240 V AC, 50Hz
Dimensions (W x H x D):	360 x 97 x 301 mm
Weight:	Approx. 3.5 kg
Power consumption:	18 W (in operation), less than 6 W (standby mode)

Electrical characteristics

Video input:	0.5 - 2.0Vp-p, 75 ± 5 ohms
Video output:	1.0 ± 0.2Vp-p, 75 ± 5 ohms
Audio input:	-3.8 dBs, more than 10 kohms
Audio output:	-3.8 dBs, less than 1 kohm
Video S/N:	More than 43 dB
Horizontal resolution:	More than 240 lines

Appearance and specifications are subject to change without notice.

GUARANTEE TO CUSTOMER

Sanyo U.K. Sales Ltd. (the Company) guarantees to the initial retail purchaser that if this equipment is or becomes defective and that, in the opinion of the Company, the defect is due to faulty material or workmanship the Company will, for a period of 12 calendar months from the date of sale to the original purchaser repair or replace, at its sole option, free of charge, any such defective component part of the equipment, always provided that:-

1. The equipment has at all times been used in accordance with the operating instructions issued by the Company, and has not been connected to an electrical mains supply for which it has not been adjusted.
2. Accidental damage, or damage caused by negligence or misuse by the user, including leakage from exhausted batteries, is specifically excluded.
3. Unauthorised repairs, or any modification to the equipment which has not been expressly approved by the Company, shall render this guarantee null and void.
4. Failure due to fair wear and tear of any item, such as batteries, record playing styli, and tape recording, playback and erase heads and head cleaning is specifically excluded.

This guarantee is not transferable and is only applicable within the United Kingdom (and the Republic of Ireland). Nothing in this express guarantee affects the statutory rights available to the purchaser of this equipment.

Dear Customer

Thank you for buying Sanyo. This equipment should give you many years of pleasure and faithful service but in the event that a fault occurs, the following notes for your guidance may be helpful:-

1. PLEASE RETAIN YOUR PURCHASE RECEIPT WHICH WILL BE REQUIRED FOR SERVICE DURING GUARANTEE.
2. If your Sanyo equipment proves faulty during the period of guarantee, take it or send it back to the dealer who originally supplied it together with this guarantee and the proof of purchase. We have made arrangements with our approved dealers under which they will carry out in guarantee service repairs on our behalf. In this way, we hope to reduce to a minimum the amount of time you will be without your equipment.
3. If for some reason it is impossible to return the equipment to the original supplier, please contact our Service Administration Department at the address below for further advice.
4. Should the equipment require servicing after the expiry of the guarantee period, take or send it to the original supplier or any other Sanyo dealer. He will be pleased to give you a quotation for the repair. If you are in any doubt about what to do, write to us at the address below or telephone:

Sanyo U.K. Sales Ltd.
Sanyo House Otterspool Way, Watford, Hertfordshire WD2 8JX Tel: Watford 246363

SANYO