

Video Cassette Recorder

NV-J35 Series

Operating Instructions



Before attempting to connect, operate or
adjust this product, please read these
instructions completely.

CONTENTS

Page
3 CAUTIONS
4 CONTROLS AND COMPONENTS
6 INFRA-RED REMOTE CONTROLLER
8 INSTALLATION
9 TUNING THE TV SET TO THE VIDEO PLAYBACK CHANNEL
10 SETTING THE TUNER IN THE VTR
12 SETTING THE CLOCK TO THE PRESENT TIME
14 THE VIDEO CASSETTE
14 AUTO OPERATION
15 PLAYBACK
20 RECORDING FROM A TV BROADCAST SIGNAL
21 SUPER OTR FUNCTION (ONE-TOUCH TIMER RECORDING)
23 TIMER RECORDING
29 TIME SEARCH
30 CAMERA RECORDING
31 DUBBING (COPYING)
33 BEFORE REQUESTING SERVICE
35 SPECIFICATIONS

IMPORTANT

Your attention is drawn to the fact that recording of pre-recorded tapes or discs or other published or broadcast material may infringe copyright laws.

WARNING

TO REDUCE THE RISK OF FIRE OR SHOCK HAZARD, DO NOT EXPOSE THIS EQUIPMENT TO RAIN OR MOISTURE.

NV-J35A: Australian model

NV-J35EA: New Zealand model

FOR YOUR SAFETY

■ DO NOT REMOVE OUTER COVER.

To prevent electric shock, do not remove cover. No user serviceable parts inside. Refer servicing to qualified service personnel.

is the safety information.

HQ (High Quality) Picture System

Video recorders carrying the HQ symbol mark feature the new VHS High Quality Picture System. This system assures complete compatibility with VTRs that use the conventional VHS system.

HQ

CAUTIONS

Please read these cautions before you operate this VTR.

Cassette Compartment Door

When first unpacking the unit, you may notice that the cassette compartment door is partially open. This condition is due to the operation of a safety device designed to protect the unit from vibration during shipment; it is not a malfunction. When the AC mains lead is connected to a mains outlet, the door will return to its original position.

Avoid Sudden Changes in Temperature

If the VTR is suddenly moved from a cold place to a warm place, moisture may form on the tape and inside the VTR. In this case, the Dew Indicator "d" will flash on and off and the VTR will not operate.

Humidity and Dust

Avoid places where there is high humidity or much dust, which may cause damage to internal parts.

Do Not Obstruct the Ventilation Holes

The ventilation holes prevent abnormal increase in temperature. Do not block or cover these holes. Especially avoid covering the holes with soft materials such as cloth or paper.

Keep away from High Temperature

Keep the VTR away from extreme direct heat such as direct sunlight, heating radiators, or closed automobiles.

Keep Magnets away

Never bring a magnet or magnetized object near the VTR because it will adversely affect the performance of the VTR.

No Fingers or Other Objects Inside

Touching internal parts of this VTR is dangerous, and may cause serious damage to the VTR. Do not attempt to disassemble the VTR. There are no user serviceable parts inside.

Keep Water away

Keep the VTR away from flower vases, tubs, sinks, etc. CAUTION: If liquids are spilled into the VTR, serious damage could occur. If you spill any liquid into the VTR, consult qualified service personnel.

Cleaning the VTR

Wipe the VTR with a clean, dry cloth. Never use cleaning fluid, or other chemicals. And do not use compressed air to remove dust.

Stacking

Place the VTR in a horizontal position, and do not place anything heavy on it.

Lightning

To avoid damage by lightning, disconnect the aerial plug from the VTR.

Video Head Clogging

The video heads are the means by which the recorder places picture signals on the tape during recording, and reads picture signals from the tape during playback. If these heads become dirty and clogged from use, the signals can no longer be recorded correctly, and the playback picture will be distorted accordingly. This is the case, for example, during the playback of a tape, the sound is reproduced normally, but no picture is seen, or the picture is greatly distorted. When such a symptom case occurs have the recorder checked by qualified service personnel.

If Dew Condensation Forms in the VTR

Condensation may form in the VTR if:

- The VTR is in a room where the heater has just been turned on.
- The VTR is in a room with steam or high humidity.
- The VTR is brought from cold surroundings into a well-heated room.
- The VTR is suddenly brought from cool surroundings, such as an air-conditioned room or car, to a place which is hot and humid.

When dew forms in the VTR: (Refer to page 5.)

The Dew Indicator "d" on the Multi-Function Display will flash on and off and all the function buttons are made non-operational to protect the tape and the video heads. When the Dew Indicator flashes, wait until this indicator disappears.

- If dew condensation forms inside the VTR while the VTR On/Off Switch is off, it will turn on automatically and the Dew Indicator will flash on and off. As soon as the dew condensation has been dissolved, the VTR will turn itself off again.

CONTROLS AND COMPONENTS

FRONT

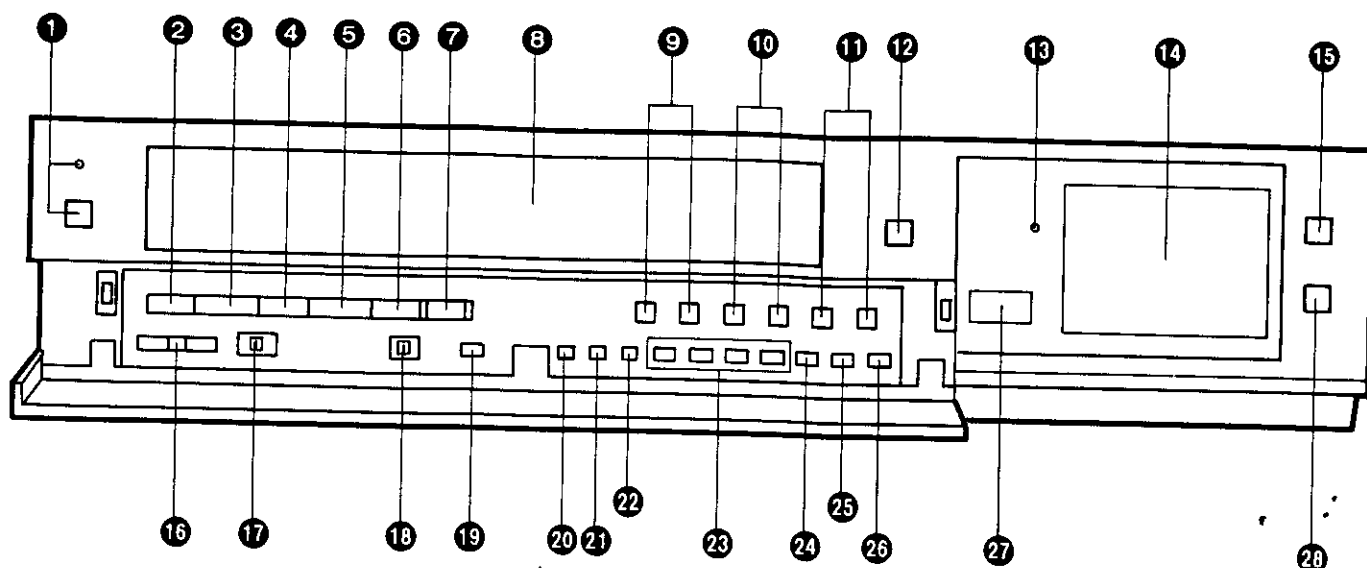

No.	Description	Page
1	VTR On/Off Switch with Indicator	9
2	Rewind ◀◀/Review ◀▶ Button	15
3	Play/x2 Button	15
4	Fast Forward ▶▶/Cue ▶▶▶ Button	15
5	Stop Button (■)	15
6	Pause/Still Button ()	15
7	Record Button (●)	20
8	Cassette Compartment	14
9	Channel Selection Up and Down Buttons	10
10	OTR On Buttons	21
11	OTR Off Buttons	21
12	Eject Button (▲)	14
13	Digital Tracking Indicator	18
14	Multi-Function Display	5

No.	Description	Page
15	Clock/Counter Selector	19
16	Picture Sharpness Control	15
17	Noise Filter/Edit Selector	19
18	Digital Tracking Selector	18
19	Tape Speed Selector	20
20	VTR/TV Selector	9
21	Clock Button	12
22	Preset/Fine/Normal Button	10
23	Timer Controls	10
24	Band/AFC Button	10
25	Clear Button	11
26	Timer Record Button	24
27	Infra-red Remote Control Receiver	7
28	Reset Button	19

Multi-Function Display

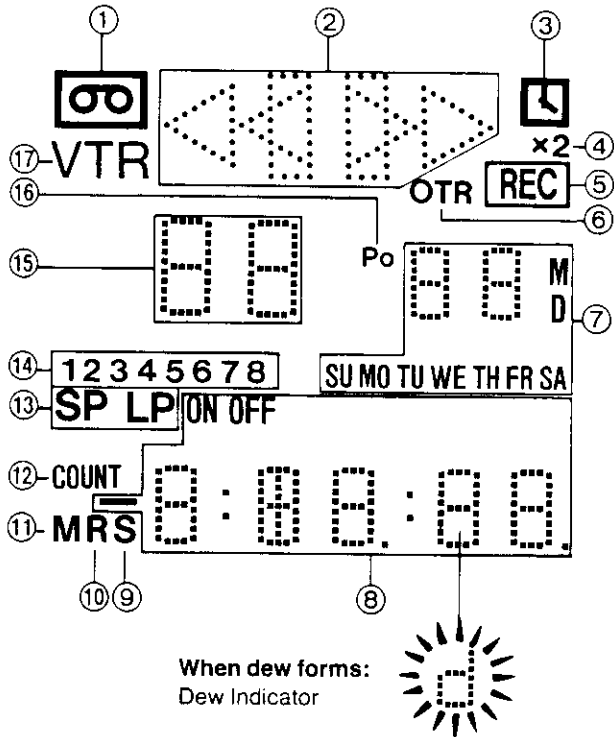

No.	Description	Page
①	Cassette-in Indicator	14
②	Tape Running Display	15
③	Timer Recording Indicator	24
④	Double Speed Indicator	15
⑤	Recording Indicator	20
⑥	OTR Indicator	21
⑦	Date Display	12
⑧	Clock/Counter Indicator	12
⑨	Search Indicator	15
⑩	Repeat Indicator	17
⑪	Memory Indicator	19
⑫	Counter Mode Indicator	19
⑬	Tape Speed Indicator	20
⑭	Timer Programme Number	23
⑮	Channel Display	10
⑯	Position Indicator	10
⑰	VTR Indicator	9

REAR

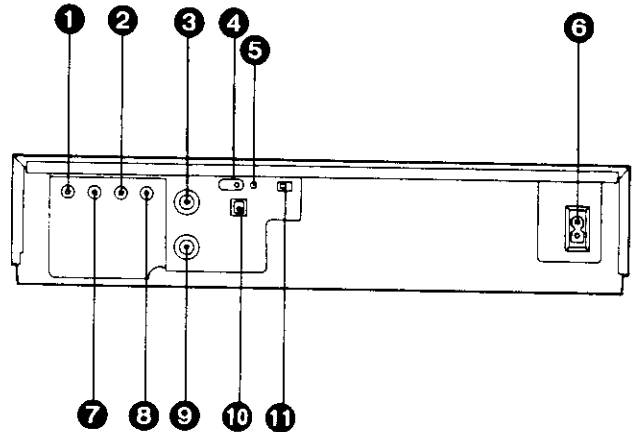

No.	Description	Page
①	Audio Input Socket	30
②	Audio Output Socket	8
③	RF Output Socket	8
④	Vertical Lock Controls	19
⑤	Synchro Edit Socket	32
⑥	AC Mains Lead Socket	8
⑦	Video Input Socket	30
⑧	Video Output Socket	8
⑨	RF Input Socket	8
⑩	Video Playback Channel Selector	9
⑪	Test Signal Switch	9

INFRA-RED REMOTE CONTROLLER

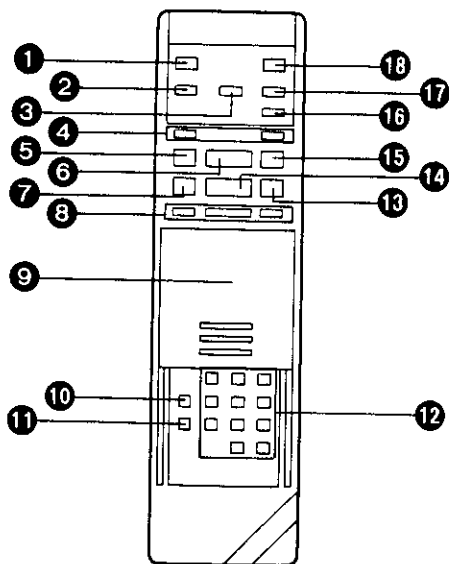

- ① VTR On/Off Button
- ② Clock/Counter Selector
- ③ Reset Button
- ④ Record Buttons (●)
- ⑤ Pause/Still Button (||)
- ⑥ Stop Button (■)
- ⑦ Rewind ◀◀/Review ◀◀ Button
- ⑧ Slow Buttons
- ⑨ Mode Selector Cover
- ⑩ Time Search Button
- ⑪ Monitor Button
- ⑫ Programme Position (Channel) Selector Buttons
- ⑬ Fast Forward ▶▶/Cue ▶▶ Button
- ⑭ Play/× 2 Button (▶)
- ⑮ Still Advance Button (||▶)
- ⑯ Reverse Play Button
- ⑰ Memory/Repeat/Search Button
- ⑱ VTR/TV Selector

Use as Digital Scanner

Slide the Mode Selector Cover downward.

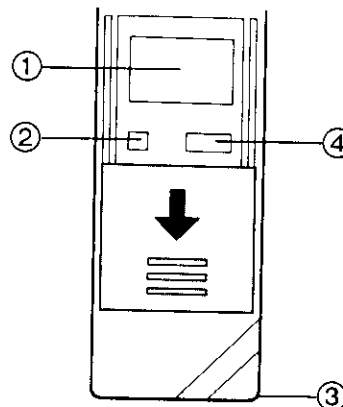

① Bar Code Reader Display

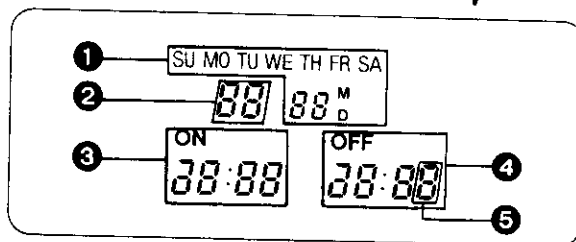

- ① Date Display
- ② Channel Display
- ③ Start Time Display
- ④ End Time Display
- ⑤ Check Indicator
- ② Digital Scanner On/Off Button
- ③ Bar Code Reading Section
- ④ Transmit Button

When the Bar Codes Cannot Be Read

Although the lamp in the tip of the Bar Code Reading Section lights up:

- No figures appear in the Bar Code Reader Display
- No beep sounds is heard;

The tip of the Bar Code Reading Section is probably clogged with dirt.

Cleaning

- ① Turn the Cap of the Bar Code Reading Section 90° counterclockwise, as shown below.

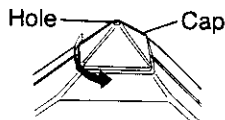

- Remove dirt and dust from the hole of the Cap.

- ② Gently wipe the tip of the lamp with a soft cloth.

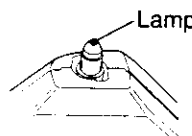

- Reattach the Cap and lock it by turning it clockwise.

How to Operate the Remote Controller (Digital Scanner)

Press the Digital Scanner On/Off Button to "ON".

- If no operation is performed for more than 25 seconds (4 minutes during setting of the clock time), the scanner will automatically switch over to the power-saving standby condition and the lamp will go off. (In this case, if bar codes have already been read but not yet transmitted to the VTR, the data will be cancelled.)
- When the lamp is not lit, press the button to "ON" again.

Tracing the Bar Codes

- (A) Place the Remote Controller on the Small Box.
- (B) Trace the bar code quickly in the direction of the arrow.

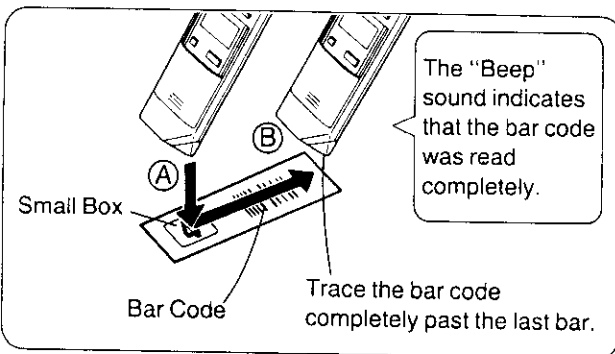

- Treat the Programming Sheet with care. If the sheet gets dirty or scratched, the bar code reading may become impossible.
- Protect the Remote Controller from strong shocks and vibration. Keep it away from water and places with high temperature and humidity.
- If the bar code is traced slowly, it cannot be read correctly.
- When there is no "Beep" sound, the reading of the bar code is incomplete. Always check your Display Window to confirm the function scanned has been accepted.
- When using the Programming Sheet, put it on flat surface: Reading the bar codes while holding it in your hand or bending it, may result in incorrect operation.
- Do not deviate from the bar code, nor stop tracing halfway.

Power Source for the Remote Controller

- The Remote Controller is powered by 2 IEC "R6" size batteries. The life of the batteries is about one year, however, it depends on the frequency of use. Inspect and if necessary, replace the batteries once a year.

CAUTION FOR BATTERY REPLACEMENT

- Load the new batteries with their polarities (+ and -) aligned correctly.
- Do not apply heat to batteries, or internal short-circuit may occur.
- If you do not intend to use the Remote Controller for a long period of time, remove the batteries and store them in a cool and dry place.
- Remove spent batteries immediately and dispose of them.
- Do not use an old and a new batteries together. (Also never use an alkaline battery with a manganese battery.)

Load the batteries as follows:

- 1 Push back the battery compartment locking lever.

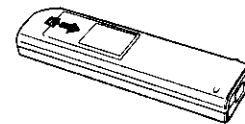

- 2 Lift off the battery compartment lid.

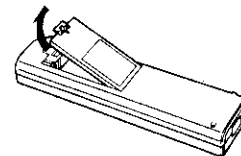

- 3 Insert the batteries with their polarities aligned as indicated inside the battery compartment.

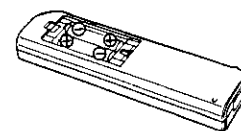

- 4 Replace the lid.

Note:

- The infra-red beam should be transmitted directly at the Infra-red Remote Control Receiver on the front of the VTR.
- Direct sunlight may interfere with the beam.
- The lightsensing angle of the Infra-red Remote Control Receiver in the VTR is about 30° for each side from the centre.
- The unit should be used within a range of about 7 meters from the front of the VTR.

Recommendation

After the programming of timer recording(s) is completed, press the Digital Scanner On/Off Button so that the indications in the LCD Display disappear, in order to save battery power.

INSTALLATION

Connection to a TV Set

NV-J35A:

FOR YOUR SAFETY

Install any external aerial to AS 1417.1.

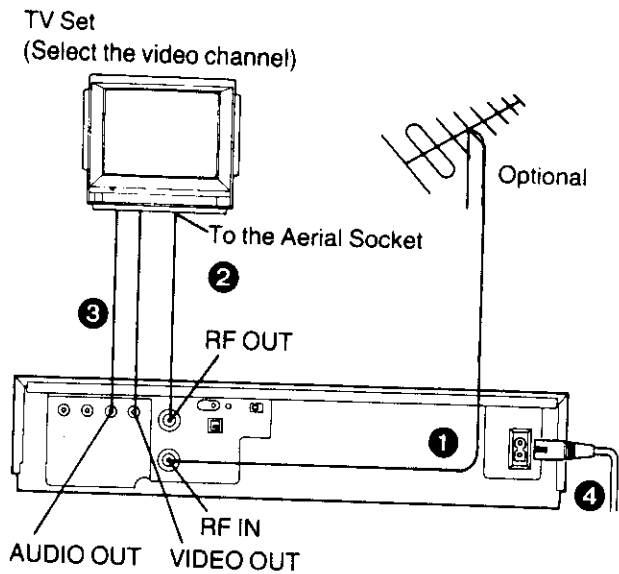

- 1 Connect the external aerial to the RF Input Socket on the VTR.
- 2 Connect the aerial terminal on your TV set to the RF Output Socket on the VTR with the supplied DIN-DIN Coaxial Cable.
- 3 If the TV set is equipped with separate video and audio input sockets, it is recommended to connect the VTR to the TV set with separate video and audio cables. (not supplied)
- 4 Connect the AC Mains Lead to the AC Mains Socket of the VTR to the mains outlet.

TUNING THE TV SET TO THE VIDEO PLAYBACK CHANNEL

The adjustments described on this page are not necessary, if the VTR is connected to the TV set via the Video/Audio output sockets.

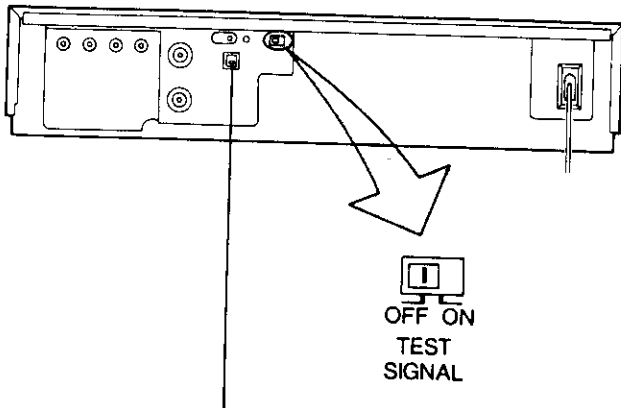

Video Playback Channel Selector

This switch is used to select the Video Playback channel which is not occupied with any TV station. [NV-J35A: 0 or 1; NV-J35EA: 2 or 3]

- 1 Turn the TV set on and select the programme position that is not occupied by any TV station.
- 2 Press the VTR On/Off Switch to turn the VTR On. (FRONT SIDE)

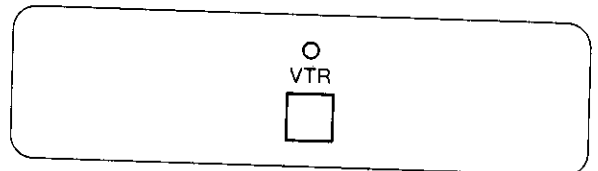

• The corresponding indicator lights up.

- 3 Set the VTR/TV Selector to "VTR". (FRONT SIDE)

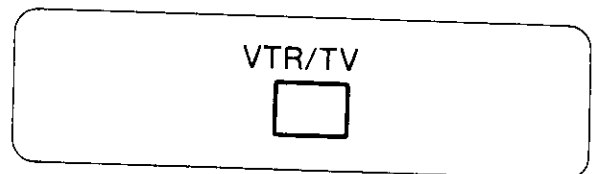

• VTR/TV Indicator will appear in the Multi-Function Display.

- 4 Set the Test Signal Switch to "On".

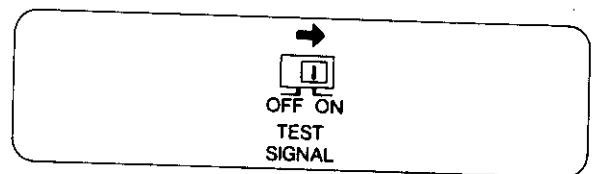

- 5 Tune your TV to VHF channel as shown below. Confirm by your TV that the received test pattern is as shown below.

NV-J35A: VHF channel 0 or 1*
NV-J35EA: VHF channel 2 or 3

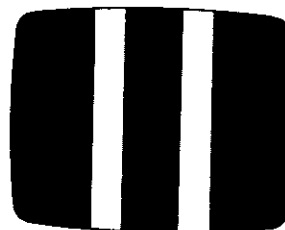

NV-J35A only
*In some areas channel 0 may be used by local TV station. In this case switch to channel 1.

- 6 Set the Test Signal Switch to "Off". Your TV is now ready to receive the RF output signal from the VTR.

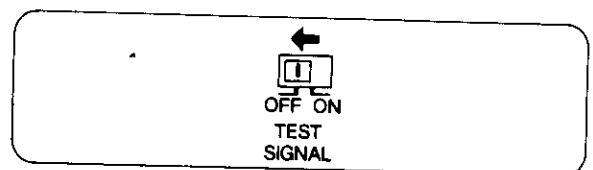

- 7 To check, playback a pre-recorded tape and confirm that the picture quality is satisfactory.

SETTING THE TUNER IN THE VTR

The tuner in the VTR makes it possible to receive TV broadcasts and to record these programmes without having to turn on the TV set.

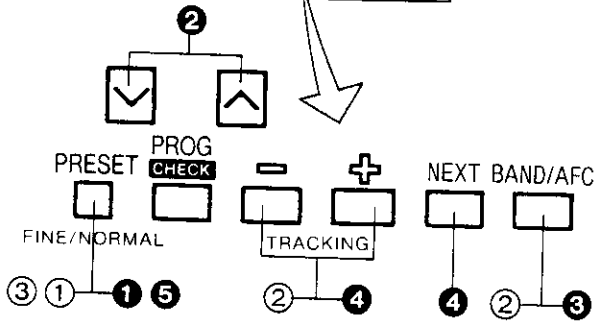
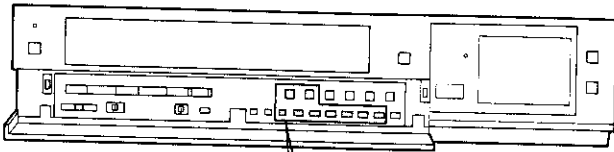

Preparation

- Turn the TV set on and select the programme position (channel) which you have tuned to the video playback channel.
- Press the VTR On/Off Switch to turn the VTR on.
- Set the VTR/TV Selector to "VTR".

PRE-PROGRAMMED TV CHANNELS (NV-J35A)

The local TV transmission channels 2, 7, 9 and 10 are factory-preset in this VTR. That is, if you can receive television broadcasts on VHF channels 2, 7, 9 and 10, these are already tuned on the programme positions with the matching numbers. However, it is possible to cancel these presettings and tune the local TV broadcast channels on any desired programme positions. For alternative settings and tuning of additional TV broadcasts channels, follow the Tuning Procedure below.

Tuning Procedure

- 1 Press the Preset/Fine/Normal Button. The indication on the Multi-Function Display changes from the clock indication to the position indication.
- 2 Press the Channel Up or Down Button to select a programme position (channel) which you want to tune to a TV station.
- 3 Press the Band/AFC Button to select the "I", "III" or "U" position.

Display of the programme positions 1-99

16 ^{PO} 16

6: III

Indication of the selected TV band

Selection of the programme position

	VHF		UHF
	I	III	U
NV-J35A	0-5	5A-11	21-69
NV-J35EA	1-3	4-11	21-69

The tuner in the VTR can be preset with up to 99 stations.

- 4 Press the "+" or "-" Button until the picture of the desired station on your TV is satisfactory.
 - If the "+" or "-" Button is pressed while pressing the Next Button, the stations will change quickly.

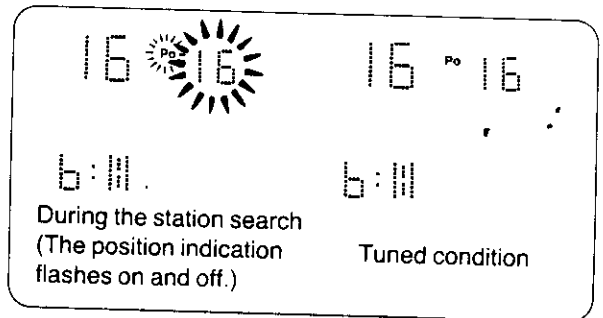

- The tuned station is automatically memorized.

Repeat steps 2-4 for each channel you want to tune to a station.

- 5 Press the Preset/Fine/Normal Button twice. The indication on the Multi-Function Display changes back to the previous indication.

Fine Tuning Procedure

If fine tuning is necessary, for example for a weak station which is close to a strong station:

- 1 Press the Preset/Fine/Normal Button twice.

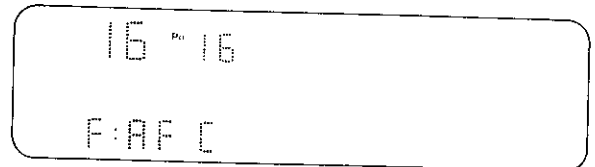

- 2 Press the "+" or "-" Button to obtain the best tuning condition.

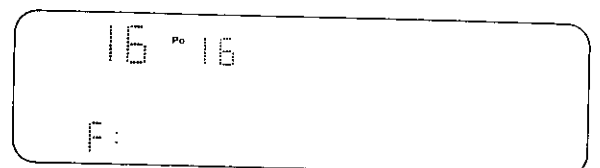

- "AFC" Indicator will not be displayed.

• To return the tuning to its former state, press the Band/AFC Button.

- 3 Press the Preset/Fine/Normal Button.

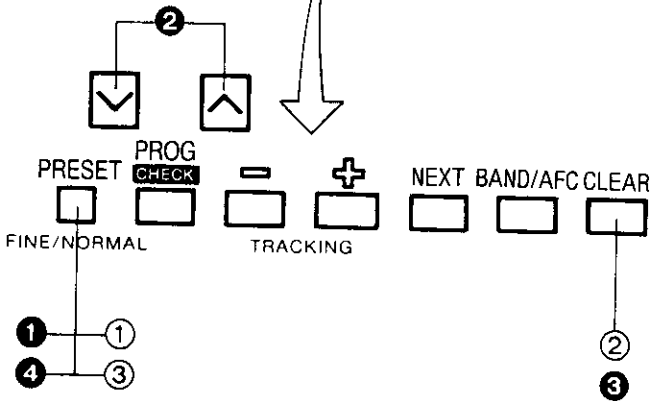
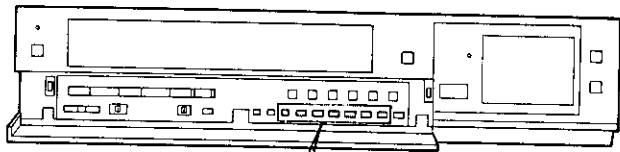

Blanking of Unoccupied Programme Positions

- 1 Press the Preset/Fine/Normal Button.
- 2 Press the Channel Up or Down Button to select a programme position (channel) which you do not want to tune to a TV station.
- 3 Press the Clear Button ("--") will be displayed in the Programme Position Indication).



• Repeat steps 2 and 3 for any programme positions on which no stations are to be tuned. Afterwards, these programme positions will be skipped during Up/Down selection of the programme position.

- 4 Press the Preset/Fine/Normal Button twice.

Cancelling the Clear Function (Blanking)

- 1 Press the Preset/Fine/Normal Button.
- 2 To cancel the blanking of a programme position, select that programme position on the VTR and then press the Clear Button.
- 3 Press the Preset/Fine/Normal Button twice.

How to Select the Programme Position (Channel) on the Remote Controller

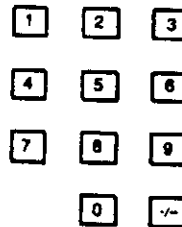
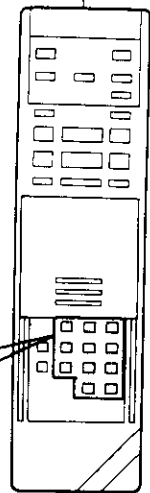
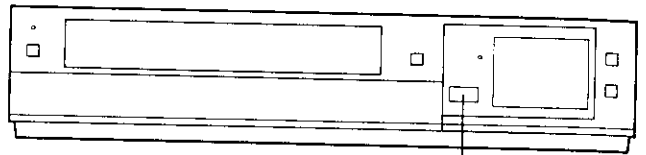

select channel

press button

1-9	[1] → [9]	respective channel
10	[-] → [1] → [0]	
20	[-] → [2] → [0]	
11-99 for example 32	[-] → [3] → [2]	

If more than 5 seconds pass between the first, second and third push, the channel will not be changed normally.

SETTING THE CLOCK TO THE PRESENT TIME

The built-in digital clock employs the 24-hour system.

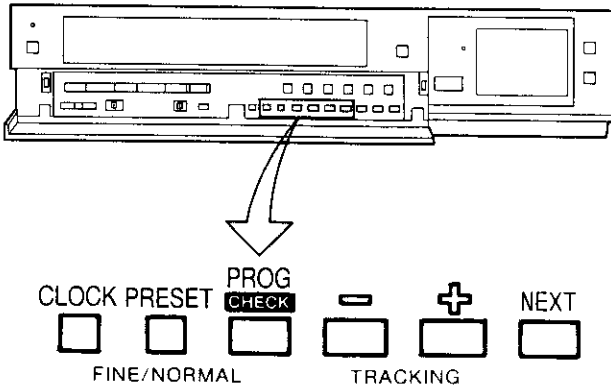

For Example: Set the clock for Sunday, October 10, 1999, 9:10

- Connect the VTR to the mains outlet.
- Press the VTR On/Off Switch to turn the VTR On.

- When connecting this VTR to the mains or after a long power failure, the time indications flash.

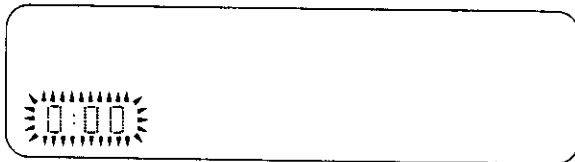

- Press the Clock Button to start the date and time setting.

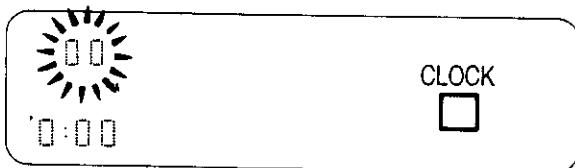

- Press the "+" or "-" Button to set the year.



- Press the Next Button.

- Press the "+" or "-" Button to set the month.

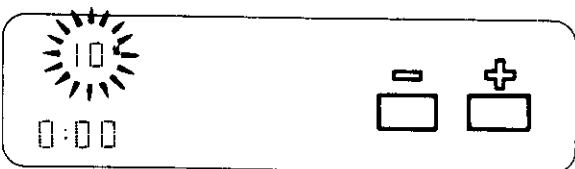

- Press the Next Button.

- Press the "+" or "-" Button to set the date.



- Press the Next Button.

- Press the "+" or "-" Button to set the hour.



- Press the Next Button.

- Press the "+" or "-" Button to set the minute.

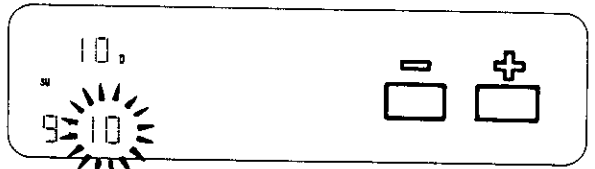

- Press the Clock Button when the present time becomes exactly 9:10'00".

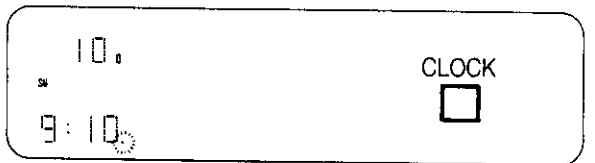

At every push of the Next Button, the flashing indication changes in the following order.

YEAR→ MONTH→ DATE→ HOUR→ MINUTE

- In case of a power failure, the timer back-up system maintains the clock operation and timer content for at least 60 minutes. However, depending on the charging time and the memory content, the back-up time may be considerably longer. However, it takes more than 60 minutes for the back-up circuit to become operational, after the VTR is connected to the mains.
- The Timer Record Function should be set to "Off", otherwise the VTR cannot be operated normally. In this case, the Timer Record Indicator "☐" will flash to warn you.
- During date setting, the corresponding day is simultaneously set.
- The clock/timer of the VTR is programmed with the calendar up to the end of the year 2087. The indications 88-99 are for the years 1988-1999. The indications 00-87 are for the years 2000-2087.

Setting the Clock to the Present Time Using the Bar Codes

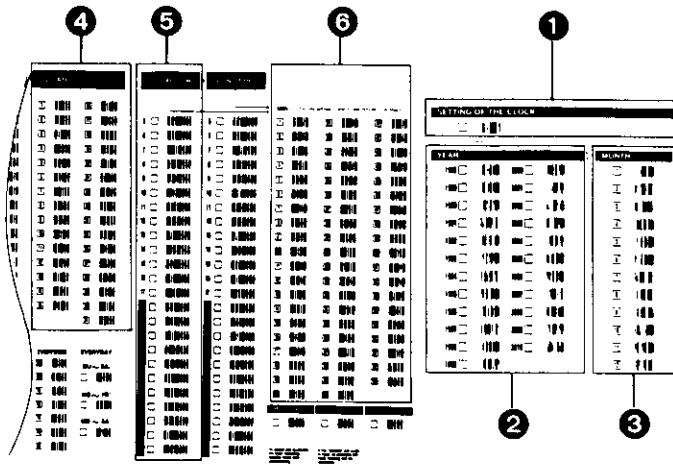

Preparation

- Slide down the Mode Selector Cover on the Remote Controller so that the Bar Code Reader Display can be seen.
- Press the Digital Scanner On/Off Button to "ON".

- Trace the bar code "SETTING OF THE CLOCK".

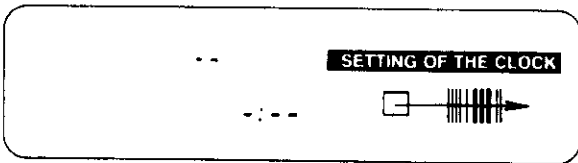

- Trace the bar code for the year (YEAR).

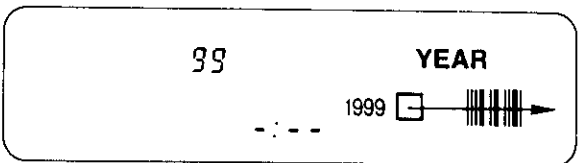

- Trace the bar code for the month (MONTH).

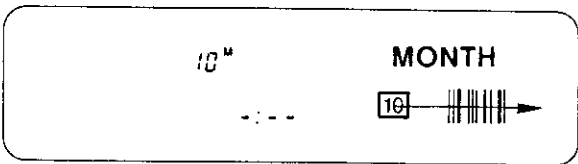

- Trace the bar code for the day of the month (DATE).

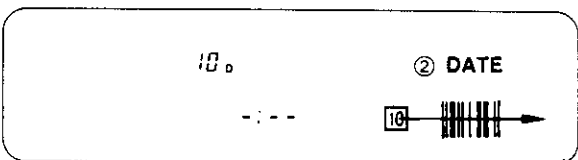

- Trace the bar code for the hour (START TIME).

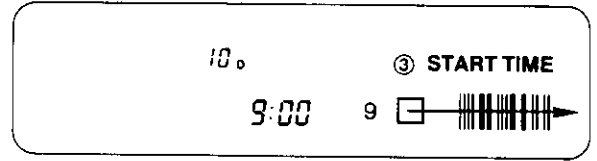

- Trace the bar code for the minute (MIN).

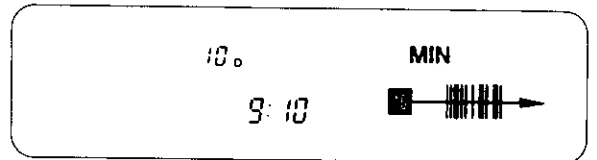

- Press the Transmit Button on the Remote Controller and then confirm that the time is displayed in the Multi-Function Display of the VTR.



"Beep-beep-beep-beep-beep..." sound indicates that the time setting is completed.

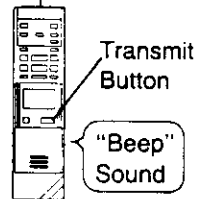

- Press the Digital Scanner On/Off Button to "OFF".

- If the transmission was not received correctly, the "Beep-Beep, Beep-Beep" sound from the VTR will warn you. In this case, perform transmission again.
- If the Remote Controller is left with no operation performed for more than 4 minutes, it will automatically switch over to the power-saving standby condition and the lamp in the reading tip goes out. In this case, bar codes that have already been read (but not yet transmitted to the VTR) will be cancelled.
- The bar codes "SETTING OF THE CLOCK", "YEAR" and "MONTH" are located on page 3 of the Programming Sheet.

THE VIDEO CASSETTE

Inserting a Video Cassette (Auto Operation)

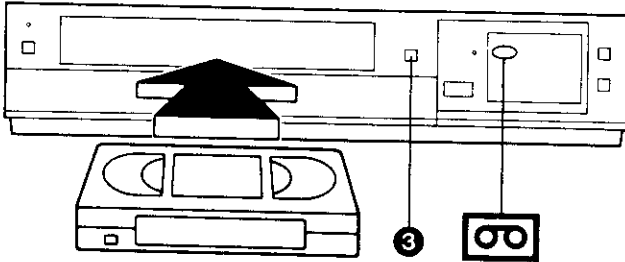

- 1 Insert the video cassette as shown. The VTR will be turned on automatically and the cassette will be automatically drawn into the VTR.
- 2 When a video cassette is inserted, the "VHS" mark will appear.

Notes:

- When a video cassette with broken out erasure prevention tab (for example a pre-recorded tape) is inserted, playback will start immediately.
- Use VHS video cassette tapes only.

Removing a Video Cassette

- 3 Press the Eject Button (▲).

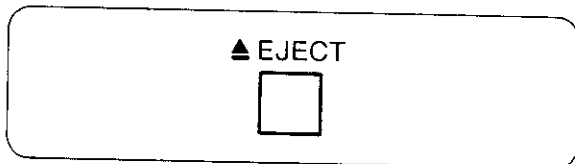

Simply press the Eject Button; the VTR turns itself on, ejects the cassette and turns itself off again.

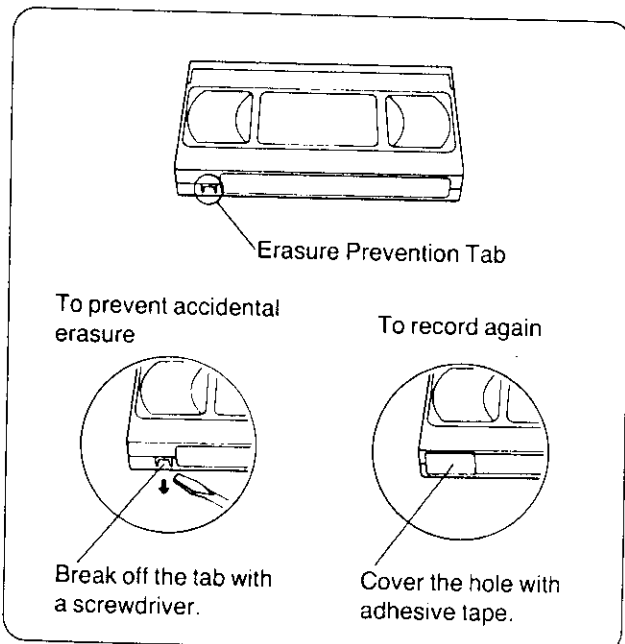

AUTO OPERATION

Auto VTR On

When a cassette is inserted, the VTR turns itself on automatically.

Auto Cue and Play

When inserting a video cassette which has the erasure prevention tab removed playback will start automatically. If nothing is recorded on the part of the tape where playback is started, the VTR will automatically be in the Cue playback mode until the recorded part is reached, then it changes back to normal playback mode.

This applies only to previously unused tapes. Tapes which have been erased or re-recorded will not exhibit this feature.

Auto Rewind

When the tape reaches its end during recording (except OTR and timer recording) or playback, it will automatically be rewound to the beginning.

Auto Eject

When trying to record on a cassette whose tab is broken out, the cassette will automatically be ejected to warn that the recording cannot be made.

VTR-Off Eject

When the VTR is off, the inserted cassette can be ejected simply by pressing the Eject Button, and the VTR will automatically turn itself off again.

Rewind Auto Shut Off

When the VTR On/Off Button is pressed during rewinding, the cassette will be ejected as soon as the beginning of the tape is reached, and the VTR will turn itself off.

PLAYBACK

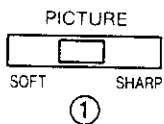
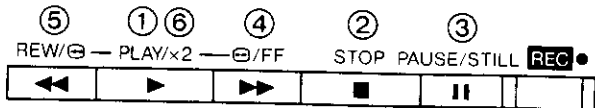
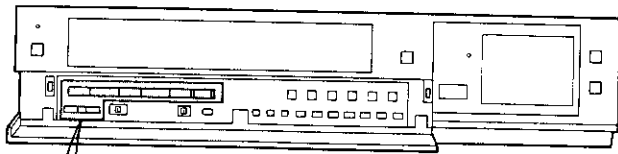

Note:

The playback functions Cue, Review, Still, Reverse, Double Speed and Slow will work only in the SP mode.

Preparation

- Make sure that the Timer Record Function is set to "Off".
- Insert a recorded video cassette.
When a video cassette is already inside the VTR, press the VTR On/Off Switch to turn it on.
- Turn the TV set on and select the video playback channel.
- Set the Noise Filter/Edit Selector to "Off".
- Set the Digital Tracking Switch to "On".

1 Normal Playback

Press the Play/×2 Button (▶).

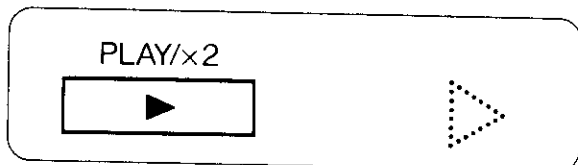

- Control the picture as you like with the Picture Sharpness Control (sharp or soft contours).

2 To Finish Playback

Press the Stop Button (■) to stop the playback.

3 Super Still Playback

When the VTR is in the playback mode, press the Pause/Still Button (||) to view a still-picture. To continue the normal playback, press this button again.

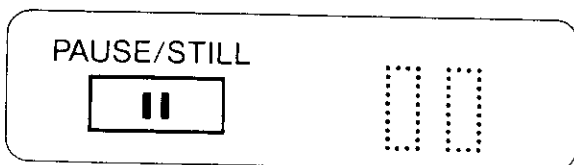

4 Cue Playback

When the Fast Forward ▶▶/Cue ⊞ Button is kept pressed while the VTR is in the playback mode, the tape will be played back at high speed in forward direction.



5 Review Playback

When the Rewind ◀◀/Review ⊞ Button is kept pressed while the VTR is in the playback mode, the tape will be played back at high speed in reverse direction.

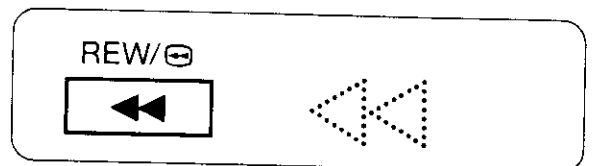

To make possible Cue or Review playback without having to keep the respective button pressed, first press the Memory/Repeat/Search Button on the Remote Controller so that the Search Indicator "S" appears in the Multi-Function Display, and then press the Fast Forward ▶▶/Cue ⊞ Button or the Rewind ◀◀/Review ⊞ Button. To switch the VTR back to normal playback, press the Play/×2 Button (▶).

- When Cue or Review playback continues for more than 10 minutes, the VTR will automatically switch back to the normal playback mode.

6 Double Speed Playback

When the VTR is in the playback mode, press the Play/×2 Button to view the action at twice the normal playback speed. To change back to normal playback, press the Play/×2 Button again.

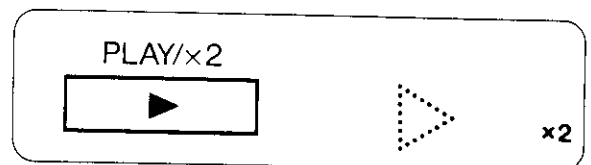

PLAYBACK (CONT'D)

Using the Remote Controller

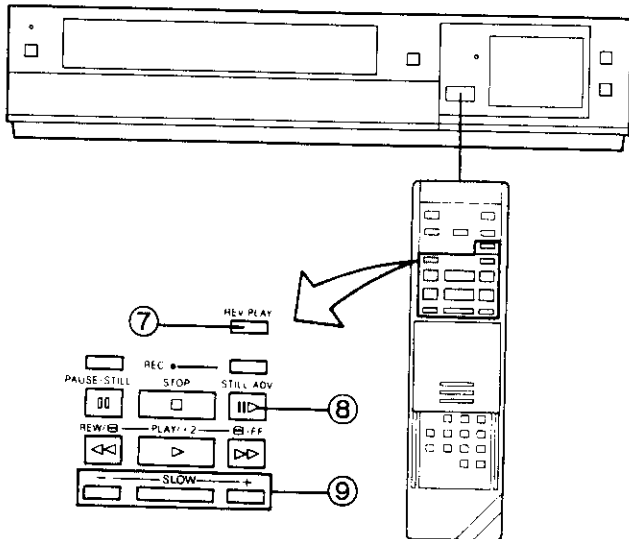

7 Reverse Playback

When the VTR is in the playback mode, switching over to Reverse Playback is possible by pressing the Reverse Playback Button.

- During Reverse Playback, noise bars may appear in the upper centre and lower centre parts of the picture.

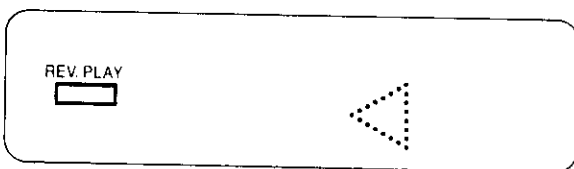

8 Super Still Advance Playback

Press the Still Advance Button (II) while the VTR is in the still playback mode. Each time you press this button, the still-picture will advance one single field.

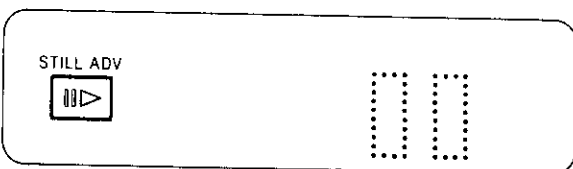

9 Super Fine Slow Playback

During normal playback, the Slow-motion playback can be activated by pressing the Slow Button. The slow-motion playback speed can then be varied by using the Slow "+" or "-" Button.

When changing the slow-motion playback speed, indicator flashes.

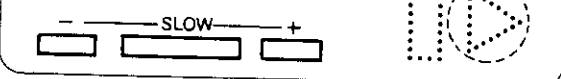

- Press the Play/x2 Button (▶) to continue the normal playback.
- If the Slow playback operation continues for more than 5 minutes, the VTR automatically switches over to the stop mode.
- While playing back a tape in the Super Still or Super Fine Slow playback mode on a TV set equipped with an automatic vertical hold control, the picture may shake vertically. In this case, set the TV set's vertical hold (Auto/Manual) selector to the "Manual" position, and adjust the vertical hold control.

Slow Tracking Control

- When noise bars appear during Super Still, Super Still Advance or Super Fine Slow playback, switch over to Slow playback and adjust with the Tracking (+) or (-) Button to reduce the noise bars.
- It may not be possible to eliminate the noise bars completely.

- The sound will be played back only during normal playback.
- If you leave the VTR in the Still and Slow playback mode for more than 5 minutes, the VTR will automatically switch over to the Stop mode to protect the tape and the video heads.
- Noise which takes the form of horizontal bars appears on the TV in the Cue and Review playback modes. This is not an indication of a malfunction.
- The top of the picture may become distorted in the Cue, Review or Super Still (LP) mode. This is not an indication of a malfunction.
- When the picture rolls vertically in the Cue or Review mode, adjust the vertical hold control on the TV set.
- Immediately after starting Cue or Review playback, the picture may be distorted. Also, when these modes are cancelled, some momentary picture distortion may occur. However, this is not due to any malfunction.
- In "LP" mode only:
 1. During any playback mode other than normal playback, the picture distorted and black and white. This is not indication of malfunction.
 2. When playing back a tape which was recorded on another VTR, it may be necessary to adjust the Tracking Control. In some cases the picture quality may still be inferior. This is due to limitation of format.

Repeat Playback

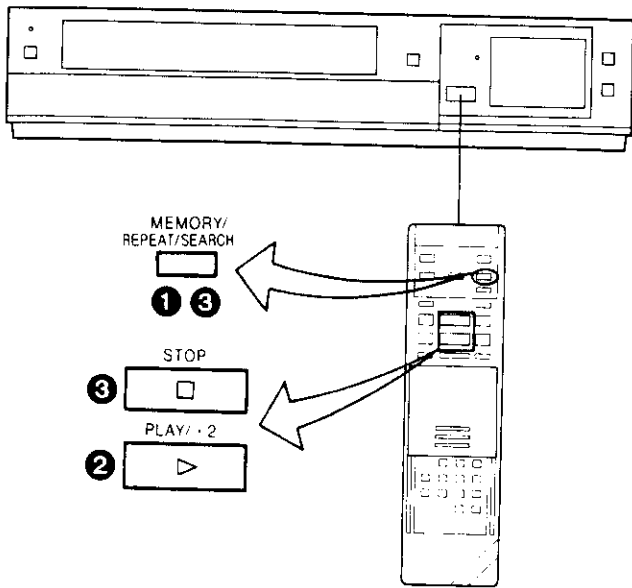

Repeat Playback between the Beginning of the Tape and the End of the Tape

- 1 Press the Memory/Repeat/Search Button so that the Repeat Indicator "R" lights up.

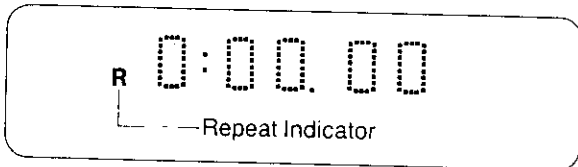

- 2 Press the Play/×2 Button.
 - The playback will continue until the end of the tape. At this point, the tape will be rewound to the beginning and the playback will be repeated.
- 3 To stop the Repeat playback, press either the Stop Button or the Memory/Repeat/Search Button (the Repeat Indicator "R" will go out).

PLAYBACK (CONT'D)

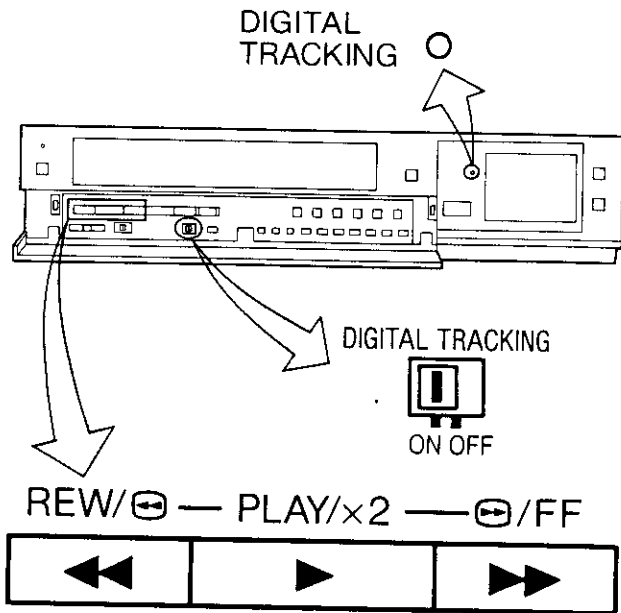

Rewind and Fast Forward

Press the Rewind /Review Button to rewind the tape.

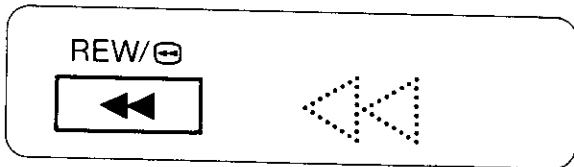

Press the Fast Forward /Cue Button to wind the tape forward rapidly.



Lap Time Counter

It shows the elapsed recording or playback time.

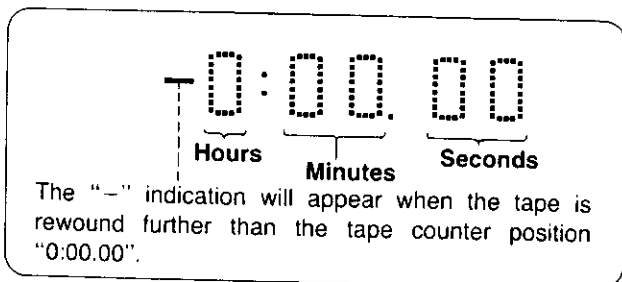

- If the figures on the Tape Counter do not change during Fast Forward, Rewind or any of the Playback functions, this means that nothing is recorded on that tape section.
- The Tape Counter is automatically reset to "0:00.00" when the video cassette is inserted.

Digital Tracking Selector

Digital Tracking

ON: Select this position for digital tracking.

When playback is started after inserting a cassette, and the VTR is turned on, the Digital Tracking function will be activated automatically, the Digital Tracking Indicator will flash for several seconds, and the tracking will be adjusted automatically (after the adjustment, the Digital Tracking Indicator will remain lit).

- When the Digital Tracking Indicator is lit and the tape speed (SP/LP) is changed, the Digital Tracking function will be activated. However, when the VTR is operating in other modes than the playback, insert editing and audio dubbing, this function will not work.
- During playback, the Digital Tracking function will be activated whenever the playback changes over from an unrecorded part to a recorded part, provided the recorded part is longer than 4 seconds.

- When the picture is distorted by noise bars, press the Tracking (+) or (-) Button to select manual tracking and adjust with these two buttons. The Digital Tracking Indicator goes out. To change back to Digital Tracking, press the Tracking (+) and (-) Buttons simultaneously.

Manual Tracking

OFF: Select this position for manual tracking.

- When the playback picture is distorted by noise bars, adjust by pressing the Tracking (+) or (-) Button.
- To return the tracking control to the former setting, press the Tracking (+) and (-) Buttons simultaneously.

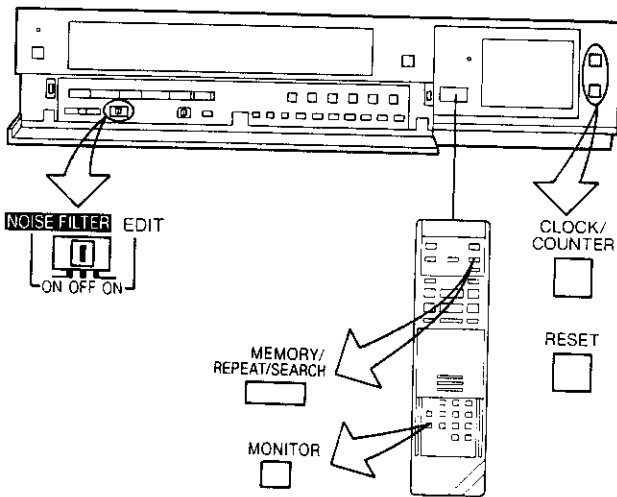

Memory/Repeat/Search Button

Repeatedly pressing this button will change the indication in the following order: "M" (Memory) → "R" (Repeat) → "S" (Search) → both indications are off → "M"...

Clock/Counter Selector

By pressing this button when the VTR On/ Off Switch is set to "On", it is possible to change over the display mode of the Clock/Counter Display in the Multi-Function Display from "Clock" to "Counter" Display and vice versa.

- Even if the selector button is set for "Counter" the display will automatically changes over to "Clock" Display in all the following cases; When you set the VTR On/Off Switch to "Off", adjust the clock to present time, programme a timer recording, check a timer recording programme or programme and perform an OTR.
- When the Clock/Counter Display shows the time, the counter cannot be reset and the Memory and Search Function cannot be activated ("M", "R" and "S" indication does not light up.)

Memory Function

The Memory function makes it simple and fast to find a certain position on the tape later again, simply by pressing the Reset Button at that position to set the tape counter to "0:00.00" and by pressing the Memory/Repeat/Search Button. During Rewind or Fast Forward, the tape will then stop at approximately the desired position.

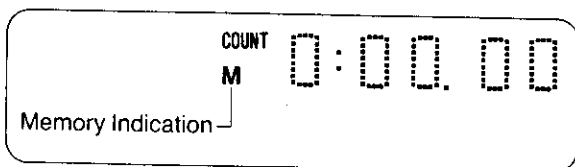

- Even if the Clock/Counter Display is switched over to "Clock" Display after pressing the Memory/Repeat/Search Button, the Memory function will stop the tape at the desired position.

Noise Filter/Edit Selector

EDIT ON: For editing operations such as dubbing.

OFF: For ordinary use of the VTR.

NOISE FILTER ON: For playback of tapes with inferior picture quality caused, for example, by repeated dubbing.

- When the Noise Filter/Edit Selector is set to "EDIT ON", the picture sharpness cannot be adjusted with the Picture Sharpness Control.

Monitoring Function

When the Monitor Button is kept pressed during Playback or Still playback, the broadcast picture of the selected programme position (channel) or input signal through Audio/Video Input Socket will be displayed. When this button is released, the picture will change back to the playback picture of the tape.

Vertical Lock Adjustment

If vertical jitter occurs during Still playback, adjust the V-Lock Control (on the rear of the VTR) for the corresponding recording tape speed with the screw driver. A one-time adjustment should be all that is necessary.

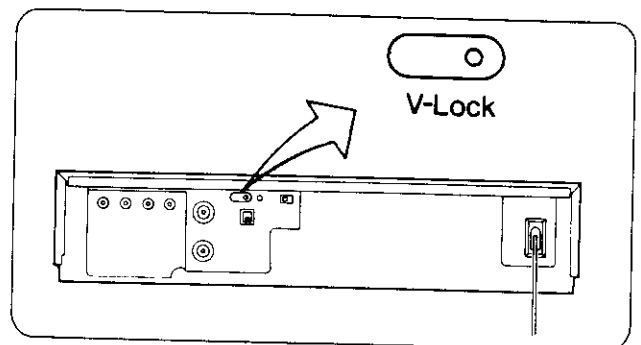

RECORDING FROM A TV BROADCAST SIGNAL

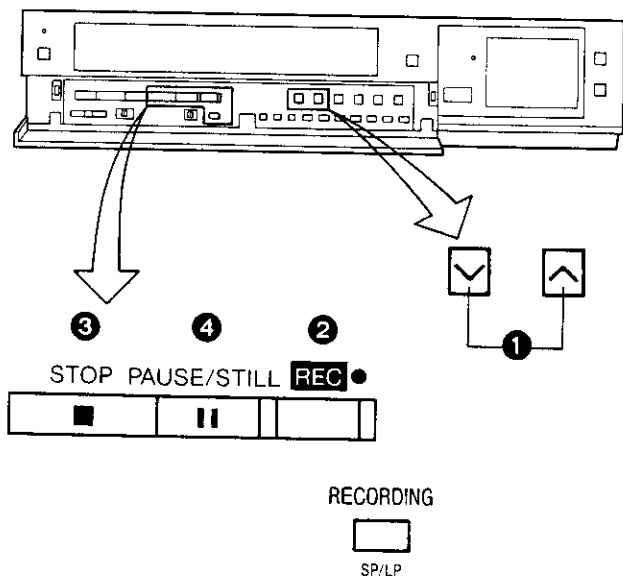

Preparation

- Make sure that the Timer Record Function is set to "Off".
- Reset the Tape Counter to "0:00.00".
- Insert a video cassette with the erasure prevention tab intact.

When a video cassette is already inside the VTR, press the VTR On/Off Switch to turn it on.

- Set the Tape Speed Selector to "SP" or "LP".
- Set the VTR/TV Selector to "VTR".

Tape Speed Selector

For recording either of two tape speeds can be selected. During playback the recorder selects automatically the correct speed.

Select the desired tape speed with the Tape Speed Selector before recording.

- Set to the "SP" position for normal speed.
- Set to the "LP" position for slow speed. The corresponding indicator (SP or LP) lights up during recording and playback in the Multi-Function Display.

It is not recommended to change from the SP to the LP mode or vice versa in the middle of recording. Even if the switching is done while the VTR is in the pause mode, picture distortion will occur at the switching point during playback.

- 1 Select on the VTR, the programme position (channel) to be recorded. In order to confirm proper reception, turn on the TV set and select the video playback channel.
- 2 Press the Record Button (●).

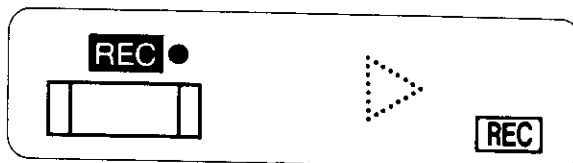

When a video cassette with broken out tab is inserted, it will be ejected automatically.

- During recording, the programme position (channel) on the VTR cannot be changed.
- To start a recording with the Remote Controller, press the two Record Buttons on the Remote Controller simultaneously.

To Finish the Recording

- 3 Press the Stop Button (■).

If You Wish to Avoid Recording Unwanted Material

- 4 Press the Pause/Still Button (||) to stop the tape temporarily.

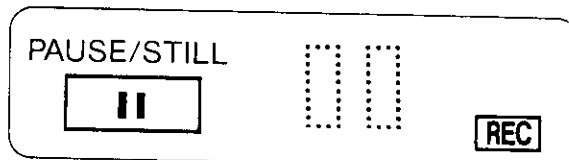

- Press the Pause/Still Button (||) again to continue the recording.
- If you leave the VTR in the pause mode for more than 5 minutes, the VTR will automatically switch over to the stop mode to protect the tape and the video heads.

Recording One TV Programme While Watching Another

1. Record (following steps 1 and 2).
2. Set the VTR/TV Selector to "TV".
3. Select the desired programme position (channel) on your TV set.

- Disconnect all cables from the Video Input and Audio Input Sockets before starting the recording. If they remain connected, it is impossible to record TV programmes.
- If pause is activated during record and the released, some colour noise may be present for a short period of tape, this is not a malfunction.

SUPER OTR FUNCTION (ONE-TOUCH TIMER RECORDING)

This convenient function makes it possible to easily programme the VTR for recording of TV programmes with immediate start or with start within 24 hours by precisely setting the starting time and ending time to the desired minute, and the VTR will automatically turn itself off when the recording ends.

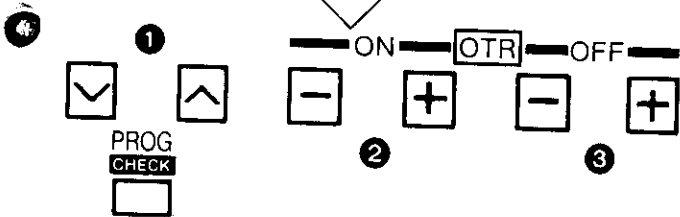
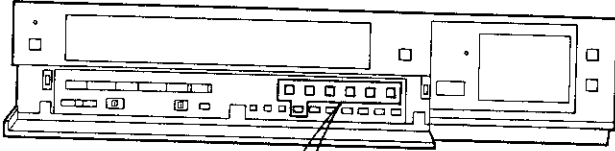

Preparation

- Make sure that the clock shows the present time correctly.
- Insert a video cassette with the erasure prevention tab intact.
- When a video cassette is already inside the VTR, press the VTR On/Off Switch to turn it on.
- Set the Tape Speed Selector to "SP" or "LP".

It is possible to programme an OTR recording for a TV programme which will start immediately or within the next 24 hours.

(For example, OTR recording of a TV programme broadcast from 10:30 to 11:00.)

- 1 Select the programme position (channel) to be recorded.
- 2 Press the OTR On (+) or (-) Button to set the OTR starting time to 10:30.

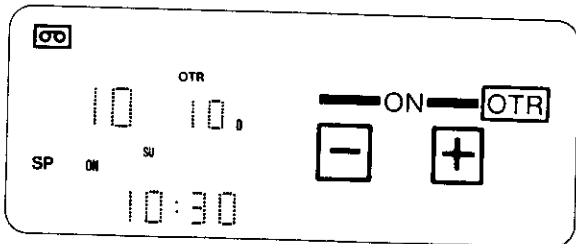

- The "OTR" indicator will be displayed.

When a video cassette with broken out tab is inserted, it will be ejected automatically.

- 3 Press the OTR Off (+) or (-) Button to set the OTR ending time to 11:00.

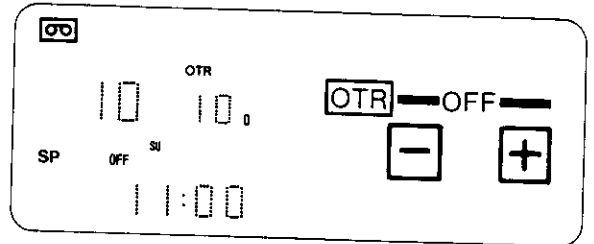

- When quickly and repeatedly pressing the OTR On (+) or (-) Button or the OTR Off (+) or (-) Button; the corresponding time indication changes in 1-minute steps. When it is kept pressed, the indication changes in 10-minute steps.
- After setting the OTR starting time in step 2, the OTR Off (+) or (-) Button must be pressed within 8 seconds to select the OTR ending time, otherwise the selected starting time will be cancelled.

After 4 seconds, the display will automatically change back to the starting time indication.

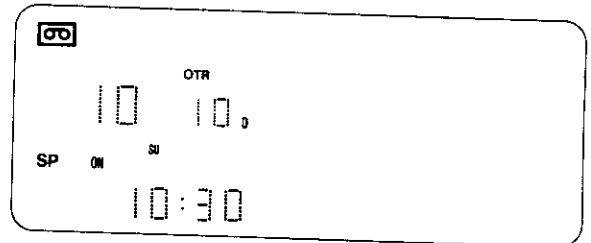

To confirm the OTR ending time, press the Check/Programme Button once. When this button is pressed twice, the display will change to the clock indication mode.

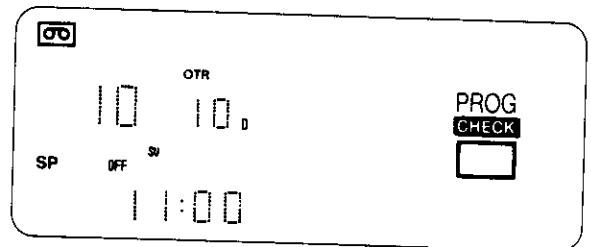

- The VTR will automatically switch off, when the OTR is completed. To turn the VTR on again, press the VTR On/Off Switch.

SUPER OTR FUNCTION (ONE-TOUCH TIMER RECORDING) (CONT'D)

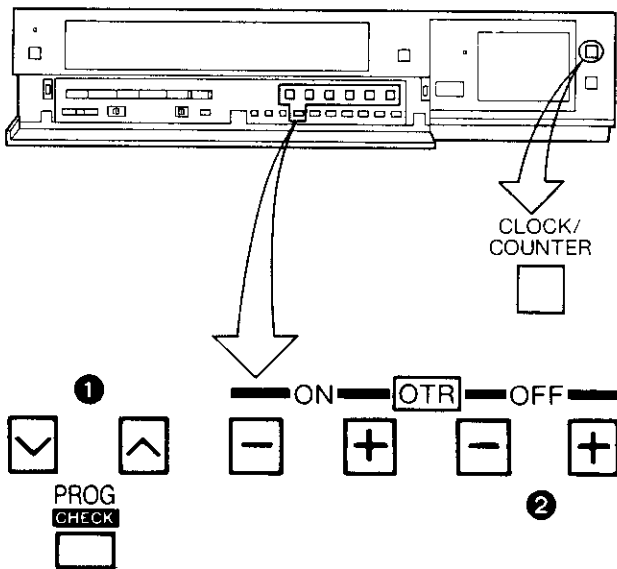

OTR Function with Immediate Start

- 1 Select the programme position (channel) to be recorded.
- 2 Press the OTR Off (+) or (-) Button to set the OTR ending time to 11:00.

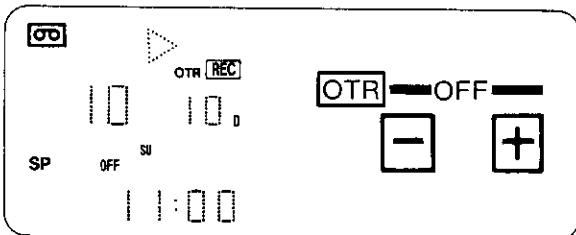

- When the tab of the inserted video cassette is broken out, it will be ejected automatically.
 - The "OTR" indicator will be displayed.
- The VTR will automatically switch off, when the OTR is completed. To turn the VTR on again, press the VTR On/Off Switch.

When the Check/Programme Button is pressed once, the present time will be displayed.

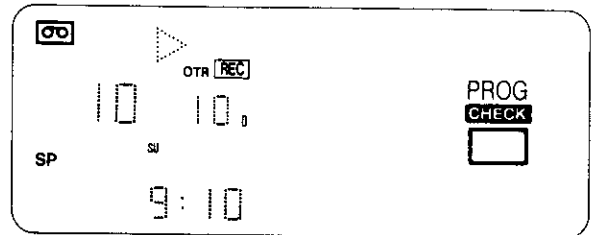

When the Clock/Counter Selector Button is pressed during OTR recording, the display will change over to the counter mode.

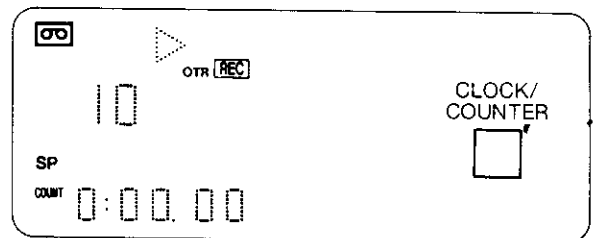

- When the tape reaches its end during an OTR the VTR will turn itself off.
- Make sure that the OTR Function (One-Touch Timer Recording) does not overlap a programmed timer recording. An OTR always takes precedence over a timer recording.
- It is possible to change the OTR starting time or the ending time before the recording starts.
- It is possible to perform any VTR operation (except timer recording) until the recording starts.
- It is possible to change the OTR ending time even during the recording.
- To interrupt an OTR, press the VTR On/Off Switch to turn the VTR off.
- Disconnect all cables from the Video Input and Audio Input Sockets before starting the recording. If they remain connected, it is impossible to record TV programmes.

TIMER RECORDING

The programming of timer recordings is possible both on the VTR itself and via the Remote Control Unit. Programming of as many as 8 timer recording is possible up to one month in advance.

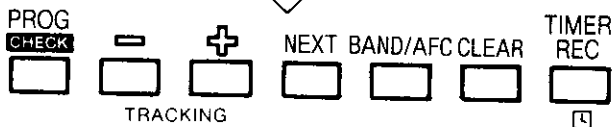
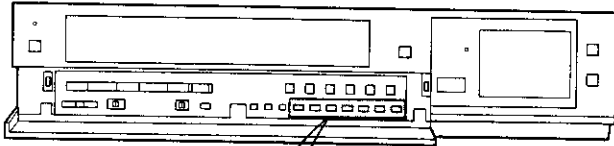

Preparation

- Make sure that the clock shows the present time correctly.
- Make sure that the Timer Record Function is set to "Off".
- Insert a video cassette with the erasure prevention tab intact.

When a video cassette is already inside the VTR, press the VTR On/Off Switch to turn it on.

For Example:

Programming a timer recording for a TV programme that will be broadcast on Wednesday, October 27, from 10:30 to 11:45, on programme position (channel) 12, on timer programme number 2. (Present date = October 10, 1999)

- 1 Press the Check/Programme Button to select the next unoccupied timer programme number.
 - Press the Tape Speed Selector Button until the Indicator of the desired tape speed ("SP" or "LP") is lit in the Multi-Function Display.

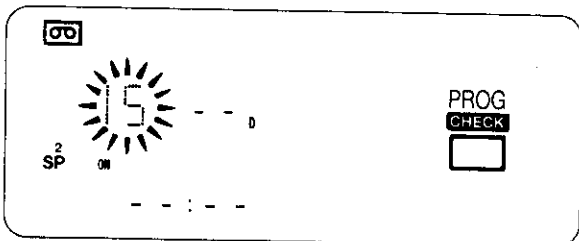

- 2 Press the (+) or (-) Button to select the programme position (channel) on which the TV programme will be broadcast.

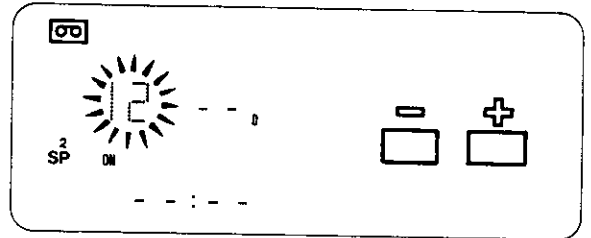

- 3 Press the Next Button.
- 4 Press the (+) or (-) Button to set the date.

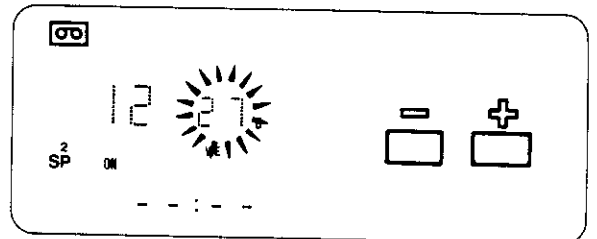

- 5 Press the Next Button.
- 6 Press the (+) or (-) Button to select the hour of the starting time of the TV programme.

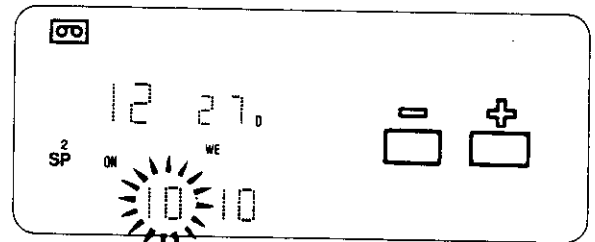

- 7 Press the Next Button.
- 8 Press the (+) or (-) Button to select the minute of the starting time of the TV programme.

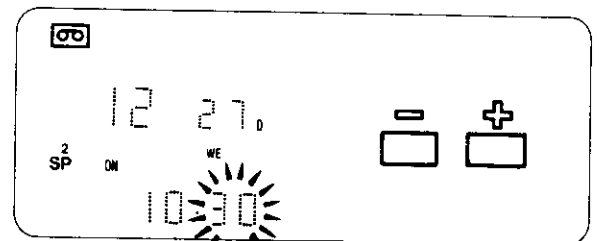

- 9 Press the Next Button.

TIMER RECORDING (CONT'D)

- 10 Press the (+) or (-) Button to select the hour of the end time of the TV programme.

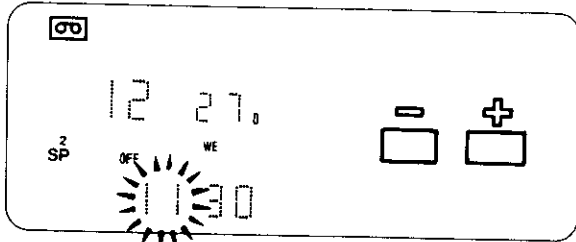

- 11 Press the Next Button.
12 Press the (+) or (-) Button to select the minute of the end time of the TV programme.

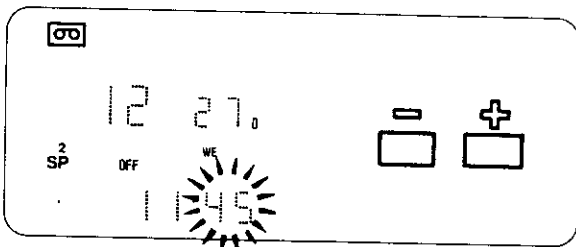

- 13 Press the Timer Record Button.

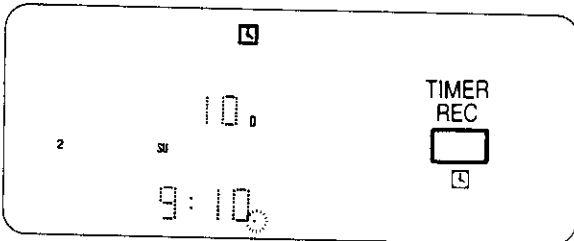

- The tape speed (SP/LP) can be selected in any of the steps 1 to 12.

For Everyweek Recording

For Example:

Programming a timer recording for a TV programme that is broadcast every week on Sunday, from 10:30 to 11:45 on timer programme number 7.

Programming for everyweek recording can be made on any of the timer programme numbers 1-8.

Execute the operation steps 1 to 3.

- 4 Press the (-) Button repeatedly until the "SU" Indicator (= Sunday) is lit.

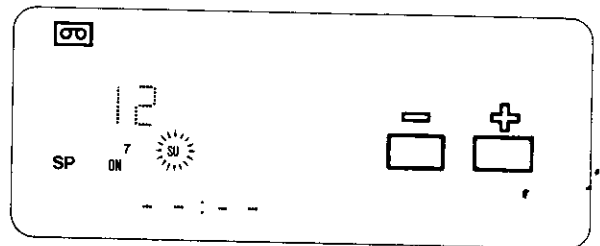

Perform the operation steps 5 to 13.

For Everyday Recording

For Everyday Recording, you have the choice between 3 different modes: Monday through Friday, Monday through Saturday, and Sunday through Saturday.

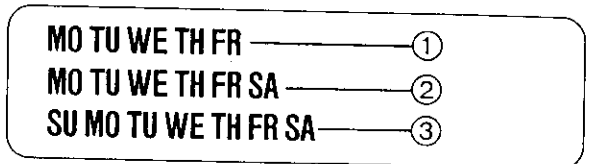

For example:

Programme time for timer recording every day from 10:30 to 11:45 on timer programme number 8.

Programming for everyday recording can be made on any of the timer programme numbers 1-8.

Execute the operation steps 1 to 3.

- 4 Press the (-) Button until the desired type of Everyday Recording (1, 2, 3) is displayed.

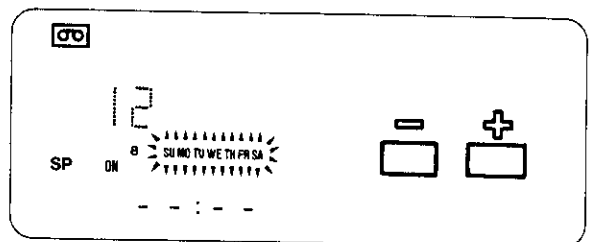

Perform the operation steps 5 to 13.

To Confirm the Programme of a Timer Recording

Make sure that the VTR is turned on.
Make sure that the Timer Record Function is set to "On".
Select the programme number to be checked, by repeatedly pressing the Check/Programme Button.
The preset channel and start and ending times of the timer recording will be indicated for about 12 seconds.

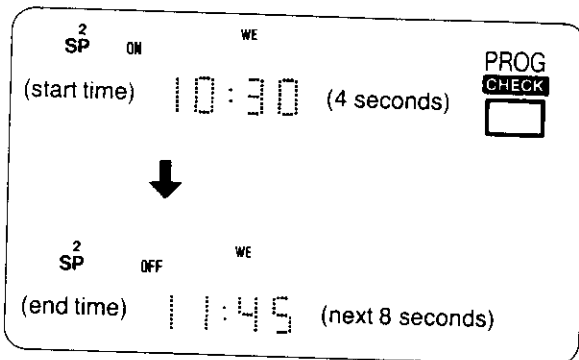

To Cancel a Timer Recording

Make sure that:
the VTR is turned on,
the Timer Record Function is set to "Off".

- 1 Press the Check/Programme Button repeatedly, until the number of the timer programme that you want to cancel is displayed.
- 2 Press the (+) and (-) Buttons simultaneously for more than 3 seconds.

- After the programmed timer recording has been made, set the Timer Record Function to "Off", otherwise the VTR cannot be operated normally.
- During recording, the programme position (channel) on the VTR cannot be changed.
- When you want to watch TV after setting a timer recording, select the desired channel on the TV set.
- To cancel a timer recording during recording, set the Timer Record Function to "Off".
- It is impossible to confirm programmes of timer recordings while an OTR is being performed.
- To turn the VTR on and use it for playback or recording before the timer recording is performed, set the Timer Record Function to "Off".
- When the Timer Record Function is set to "On" but no video cassette is inserted or no timer recording has been programmed, the Timer Recording Indicator  will flash to inform that the timer recording cannot be performed.
- If no cassette is inserted in the VTR, the "CO" Mark will flash.
- Disconnect all cables from the Video Input and Audio Input Sockets before starting the recording. If they remain connected, it is impossible to record TV programmes.

TIMER RECORDING (CONT'D)

Timer Recording by Using the Remote Controller

Tracing the Bar Codes

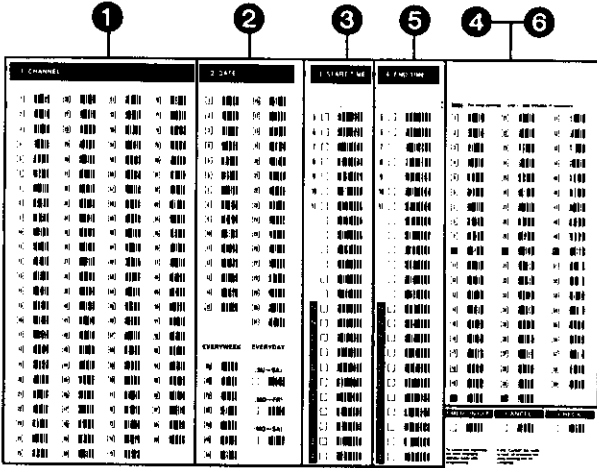

Example: When programming a timer recording for a programme that will be broadcast on channel position 4 on the 3rd of the month, from 7:02 to 7:30, trace the bar codes in the order of the numbered arrows shown below.

Press the Digital Scanner On/Off Button to "ON".

- Trace the bar code for "CHANNEL".

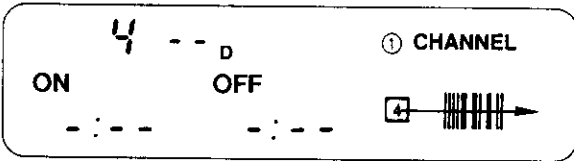

- Trace the bar code for "DATE".

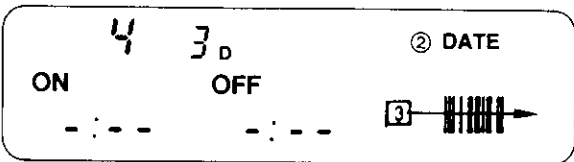

- Trace the bar code for "START TIME".

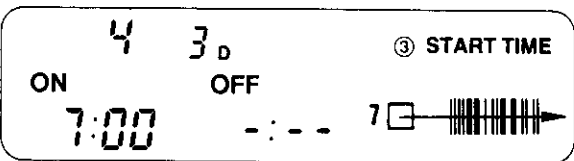

- Trace the bar code for "MIN".

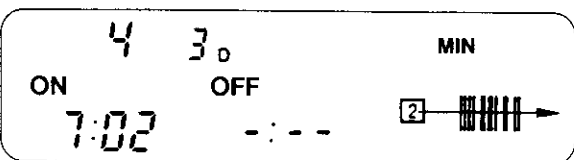

- Trace the bar code for "END TIME".

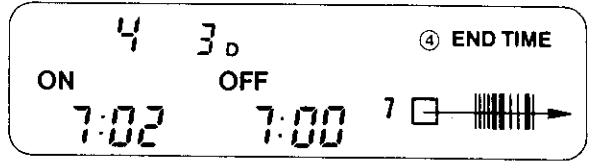

- Trace the bar code for "MIN".

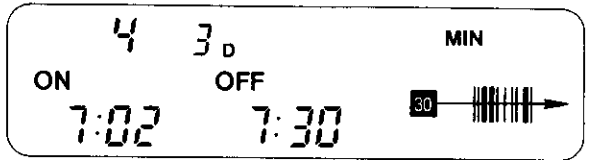

- The "Bee Bee Bee Bee Beeeeep" sound signals that the scanner is now ready for data transmission.
- When no sound is heard, read the bar codes once again.
- If more than one bar code is read in the same group, only the last code will be effective.
- If the "CANCEL" bar code is read, all bar codes that have been read so far will be cancelled.

Transmit the Programming Data

Keep pressing the Transmit Button and confirm that the programmed data on the Multi-Function Display of the VTR are as desired.

After releasing the button, the data will continue to be displayed for about 12 seconds.

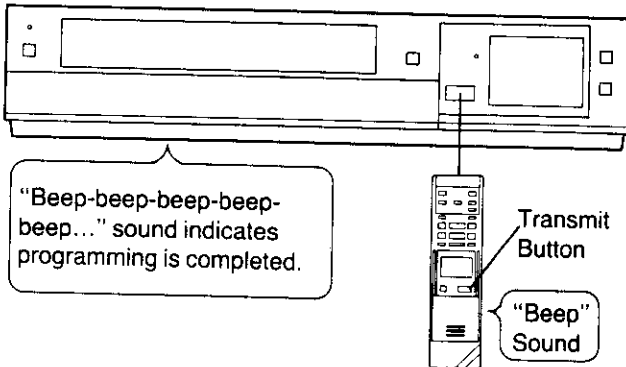

- If the transmission was not received correctly, the "Beep-Beep, Beep-Beep" sound from the VTR will warn you. In this case, perform transmission again.
- The transmission is possible when the VTR is turned on but is not in any of the recording or playback operation modes. It is also possible when the VTR is in the timer recording standby mode (⏸ indication is lit).
- The programming will be done on the next lower unoccupied timer programme number (8~1).
- If all programme numbers are occupied, the "Beep-Beep, Beep-Beep" sound from the VTR will warn you that the programming cannot be made.
- When the Transmit Button is pressed, the VTR will automatically be put into the timer recording standby condition and the VTR will be turned off.
- To operate the VTR before the timer recording will be performed, press the Timer Record Button to suspend the timer recording standby condition. After using the VTR, be sure to press the Timer Record Button again, otherwise the timer recording will not be made.

Timer On/Off

After programming a timer recording, the VTR is in the timer recording standby mode and cannot be used for any other operation, such as playback. If some other operation is desired, first trace the "TIMER ON/OFF" bar code and transmit it to the VTR with the Transmit Button.

To later reset the VTR to the timer recording standby mode, trace the "TIMER ON/OFF" bar code again and transmit it with the Transmit Button.



For Programming More Than One Timer Recording in Succession

Repeat the following operation steps ①-③.

- ① Trace the "CANCEL" bar code on the Programming Sheet.

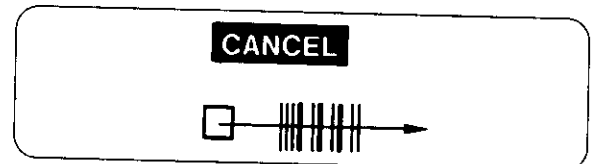

- ② Trace the bar codes for "CHANNEL", "DATE", "START TIME" and "END TIME".
- ③ Confirm that the present time is displayed on the Multi-Function Display of the VTR, and transmit the data.
 - If the next timer programming data are transmitted while the previous timer programming data are still being displayed, the displayed timer recording data will be cancelled.

TIMER RECORDING (CONT'D)

For Everyday Recording

When programming an everyday recording using the bar codes, you have the choice between 3 different modes: Sunday through Saturday, Monday through Friday, and Monday through Saturday.

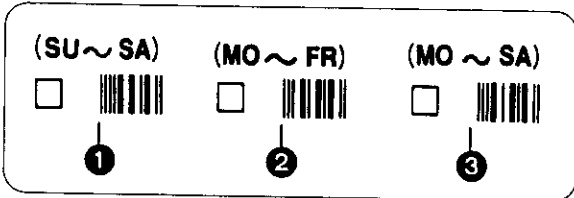

- ① Turn on the Digital Scanner and trace the "CHANNEL" bar code.
- ② Trace the desired "EVERYDAY" bar code (①, ②, ③).

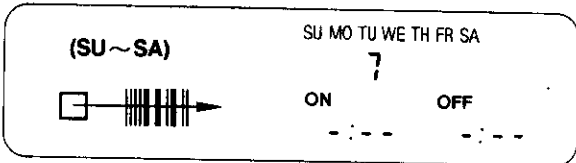

- ③ Trace the "START TIME" and then the "END TIME" bar codes, and transmit the data to the VTR.

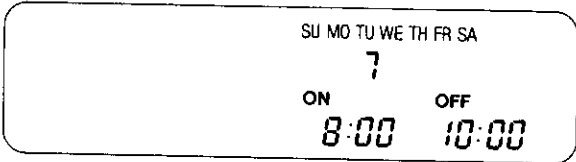

- Everyday recording will be performed from that day on.
- If a "DATE" bar code is traced after tracing the "EVERYDAY" bar code, everyday recording will not be performed.

For Everyweek Recording

- ① Turn on the Digital Scanner and trace the "CHANNEL" bar code.
- ② Trace the bar code for the desired day of the week among the "EVERYWEEK" bar codes.

EVERYWEEK

Sunday	_____	SU	
Monday	_____	MO	
Tuesday	_____	TU	
Wednesday	_____	WE	
Thursday	_____	TH	
Friday	_____	FR	
Saturday	_____	SA	

- ③ Trace the "START TIME" and then the "END TIME" bar codes, and transmit the data to the VTR.

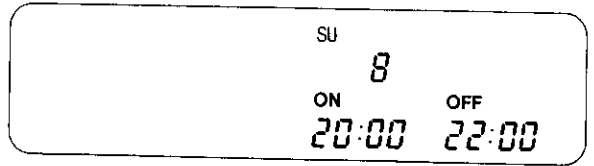

- Everyweek recording will be performed from that week on.
- If a "DATE" bar code is traced after tracing the "EVERYWEEK" bar code, everyweek recording will not be performed.

To Confirm the Programme of a Timer Recording

To perform this operation, the VTR must be turned on or it must be in the timer recording standby mode (□ indication is lit).

- ① Trace the "CHECK" bar code.

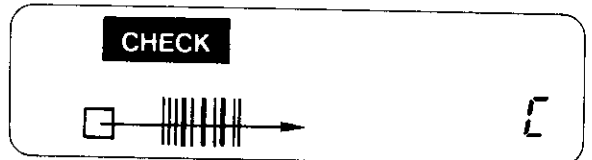

- ② Perform transmission.
 - After releasing the Transmit Button, the programmed data will be displayed for about 12 seconds on the Multi-Function Display.
 - At every push of the Transmit Button, the timer programme number advances to the next higher number.

To Cancel a Programmed Timer Recording

To perform this operation, the VTR must be turned on but not be in any of the recording or playback operation modes, or it must be in the timer recording standby mode (□ indication is lit). To cancel a programmed timer recording, its data must be displayed on the Multi-Function Display. If they are no longer displayed, first, trace the "CHECK" bar code and perform transmission (several times, if necessary, until the programme you want to cancel is displayed). Then, within 12 seconds.

- ① Trace the "CANCEL" bar code.
- ② Perform transmission.
 - To programme a new timer recording, perform the programming from the beginning.

TIME SEARCH

The Time Search function makes it possible to quickly advance the tape from any position by inputting the exact desired amount of playback time of the part that you want to skip.

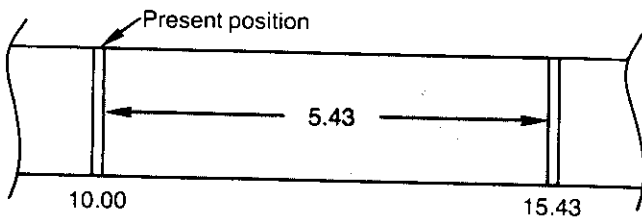

10 minutes from beginning of tape.

15 minutes 43 seconds from beginning of tape.

- 4 Press the Fast Forward **▶▶**/Cue **▶** Button or the Rewind **◀◀**/Review **◀** Button.

The playback starts after rewinding or fast forwarding to the tape position of the designated time.

Time Search from the Play Mode

The operation is the same as that for the stop mode but in operation step 4, the Cue or Review (playback) is performed to the tape position of the designated time and the playback will then start.

If the time search function is activated during playback, a time of up to 9 minutes 59 seconds can be input.

- The numbers in the Tape Counter do not change during parts of the tape on which there is no recording.
 - When the tape is inserted, the Tape Counter will automatically be reset to "0:00.00".
 - When no time is input for the time search, a .2-minute tape segment is skipped and the playback will then resume.
- If the time search function is activated during playback, but no time is input, a 30-second tape segment will be skipped and the playback will then resume.

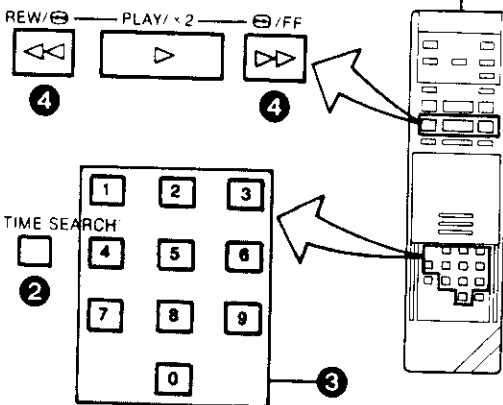
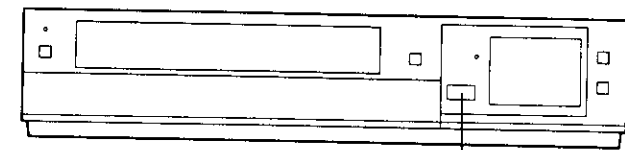

Time Search from the Stop Mode

- 1 Put the VTR in "STOP" mode.
- 2 Press the Time Search Button. The indication in the Multi-Function Display changes as shown below.

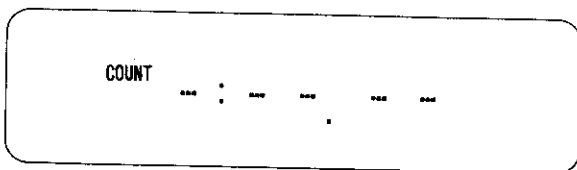

- 3 Input the time of the desired scene.
 - The time is input by pressing the number buttons in the order: hour, minute, second.
 - The "-" indication will be counted as "0".

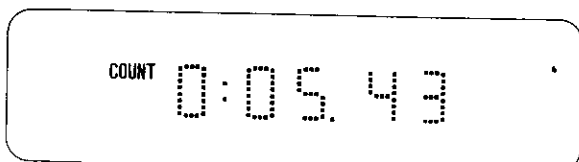

CAMERA RECORDING

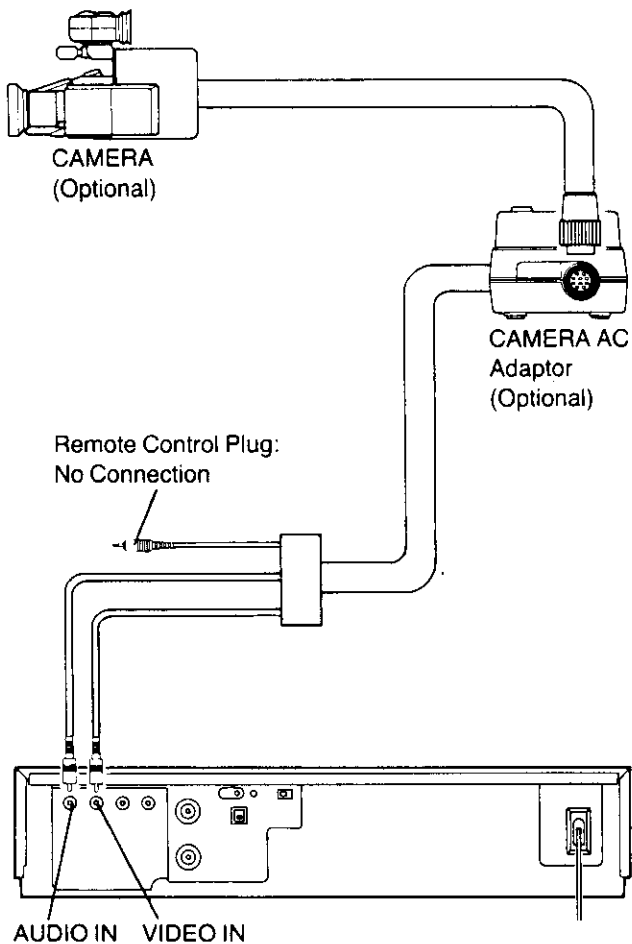

- If you leave the VTR in the pause mode for more than 5 minutes, the VTR will stop automatically to protect the tape and the video heads.
- Even if the video camera is equipped with video recorder remote control functions, this VTR can not be remote-controlled from the camera.
- Disconnect all cables from the Video Input and Audio Input Sockets after finishing camera recording. If they remain connected, it is impossible to record TV programmes.

Preparation

- Connect the Video Camera via the Camera AC Adaptor to the VTR as shown in the illustration above.
- Insert a video cassette with the erasure prevention tab intact.
When a video cassette is already inside the VTR, press the VTR On/Off Switch to turn it on.
- Set the Tape Speed Selector to "SP" or "LP".

- 1 Turn the Camera AC Adaptor on and make the necessary adjustments on the camera.
Refer to the operating instructions of the camera you are using.
- 2 Press the Record Button (●) on the VTR to start recording.

Avoid recording unwanted material:

Press the Pause/Still Button (||) on the VTR, and the recording will stop temporarily. To restart recording, press the Pause/Still Button (||), again.

- 3 Press the Stop Button (■) on the VTR to stop the recording.

DUBBING (COPYING)

Dubbing (copying) from one video cassette to another.

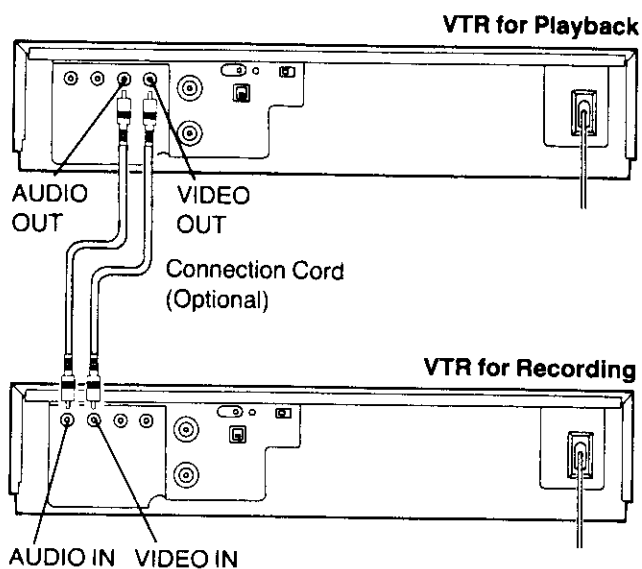

Preparation

- Make the necessary connections as shown in the connection diagram.
 - Press the VTR On/Off Switches to turn both VTRs on.
 - Make sure that the Noise Filter/Edit Selector of both the recording and playback VTRs (if equipped) are in the "EDIT ON" position. Set these switches to "OFF" for ordinary use of the VTRs.
(The Noise Filter/Edit Selector is on the front panel.)
- 1 Place the recorded cassette in the playback VTR and a blank video cassette with the erasure prevention tab intact in the recording VTR.
 - 2 Press the Record Button (●) on the recording VTR.
 - 3 Press the Play/×2 Button (▶) on the playback VTR.
 - 4 Press the Stop Button (■) on both VTRs to stop the dubbing.

- To assure smooth, noiseless cuts when interrupting the recording, always use the Pause/Still Button (||).
- To obtain smooth cuts when starting the recording from the stop mode:
 1. Play back the last part of the previously recorded material to confirm its ending point, and then press the Pause/Still Button (||).
 2. Press the Record Button (●).
(The VTR is still in the pause mode.)
 3. To start recording, press the Pause/Still Button (||) again.
- The picture quality of a re-recorded tape is not as good as that of the original.
- Disconnect all cables from the Video Input and Audio Input sockets after finishing the recording. If they remain connected, it is impossible to record TV programmes.

DUBBING (COPYING) (CONT'D)

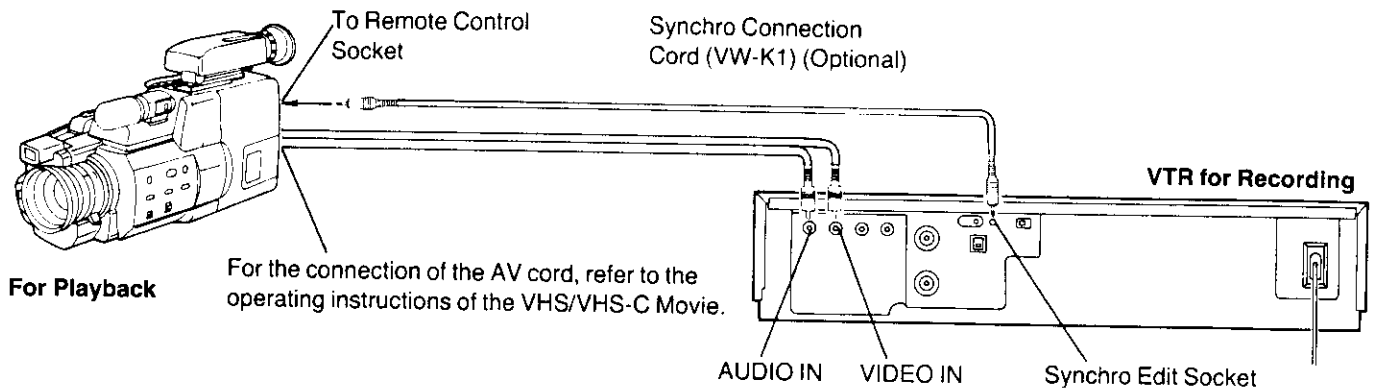

Connecting to a VHS/VHS-C Movie Equipped with Synchro Edit Function

It is possible to synchronize the playback start and stop of the VHS/VHS-C Movie with the recording start and stop of this VTR.

Preparation

- Make the necessary connections as shown in the connection diagram.
 - Set the Edit Switch (Noise Filter/Edit Selector) on both the VHS/VHS-C Movie and on this VTR to "ON" (or "EDIT ON").
- ① Put the VTR in the recording pause mode.
 - ② Put the VHS/VHS-C Movie in the still playback mode.
 - Put the Movie at the point where you want to start editing into the still playback mode.
 - ③ Press the Pause/Still Button on the VTR.
 - The VHS/VHS-C Movie changes over to the playback mode and the dubbing will start automatically.

To Leave Out Unwanted Scenes

- ① Press the Pause/Still Button on the VTR.
 - The VTR changes over to the recording pause mode and the VHS/VHS-C Movie changes over to the still playback mode.
- ② Operate the VHS/VHS-C Movie to skip the unwanted scenes and then put it in the still playback mode again.
- ③ Press the Pause/Still Button on the VTR.
 - The dubbing will restart.

To stop the dubbing, press the Stop Button on the VTR and then put the VHS/VHS-C Movie in the stop mode.

BEFORE REQUESTING SERVICE

Before requesting service, check the following points once again.

SYMPTOM	CAUSE	REMEDY
Power doesn't turn on.	Mains lead is not connected.	Connect mains lead to mains outlet.
	The Timer Record Function is set to "On".	Set the Timer Record Function to "Off".
Power is on but unit doesn't operate.	Dew condensation inside the VTR.	Wait until the Dew Indicator "d" goes off.
	Safety devices are operating.	Turn off the VTR On/Off Switch, disconnect mains cord from outlet, then reconnect mains cord to mains outlet and turn on the VTR On/Off Switch again.
TV programmes cannot be recorded.	Connection of aerial lead is not correct.	Connect aerial lead correctly.
	Reception channel is not properly tuned.	Tune reception channel.
	Cables are connected to the Video Input and Audio Input Sockets.	Disconnect all cables from the Video Input and Audio Input Sockets.
OTR Function (One-Touch Timer Recording) cannot be performed.	Clock is flashing "0:00".	Set clock to present time.
Unattended timer recording cannot be performed.	Recording start or recording stop time setting is incorrect.	Set recording start and recording stop time correctly.
	The Timer Record Function is set to "Off".	Set the Timer Record Function to "On".
	Clock shows incorrect time.	Adjust clock to present time.
	Clock is flashing at "0:00".	Set clock time and perform timer setting.
If you attempt to carry out Recording, Timer Recording, or OTR, the cassette will be automatically ejected.	Accidental erasure prevention tab on the cassette is broken out.	Cover tab hole with adhesive tape.

BEFORE REQUESTING SERVICE (CONT'D)

SYMPTOM	CAUSE	REMEDY
Playback picture is not in colour. Playback picture has large amounts of "snow".	Reception channel was not adjusted correctly during recording.	Readjust reception channel correctly.
	TV set is not properly tuned to the video playback channel of the VTR.	Properly tune the TV set to the video playback channel of the VTR.
	The video heads are clogged with dirt.	Consult qualified service personnel.
	The video heads are abraded.	Consult qualified service personnel.
	Tape is old and/or defective.	Use new tape.
Remote Controller does not work.	Remote Controller is not being pointed at Infra-red Receiver Window on the VTR.	Point the Remote Controller at Infra-red Receiver Window on the VTR.
	Distance is too far.	Use the Remote Controller within 7 m from the VTR.
	An obstacle is between Remote Controller and VTR.	Remove obstacle.
	Batteries are exhausted.	Replace batteries.
	Battery polarities (+, -) are reversed.	Insert batteries correctly.
Bar code reading with Remote Controller is impossible.	The Remote Controller is in the power-saving standby condition.	Press the Digital Scanner On/Off Button to "ON" again.
	The bar code has been traced too slowly.	Trace the bar code quickly.
	The bar code was not traced all the way from the Small Box past the last bar.	Trace the bar code correctly.
	The bar code was not traced straight.	Trace the bar code straight from left to right.
Transmission from the Remote Controller to the VTR cannot be performed.	The VTR is turned off.	Turn the VTR on.
	The VTR is in an operation mode.	Put the VTR into the stop mode.
	There is no unoccupied timer programme number left.	A maximum of 8 timer recordings can be programmed at the same time.
	Reading a bar code was not followed by a "beep" sound from the Remote Controller.	Perform the bar code reading again.
	The transmission was not followed by a repeated "beep" sound from the VTR.	Keep pressing the Transmit Button until the confirmation sound is heard.

SPECIFICATIONS

NV-J35A, EA

Power Source: NV-J35A; 240 V AC 50-60 Hz
 NV-J35EA; 230 V AC 50-60 Hz

Power Consumption: Approx. 22 watts

SEE is the safety information.

Video Recording System: 2 rotary heads, helical scanning system

Video Heads: 4 heads

Tape Speed: SP; 23.39 mm/sec.
 LP; 11.7 mm/sec.

Tape Format: VHS tape

Record/Playback Time: SP; 240 min. with NV-E240
 LP; 480 min. with NV-E240

FF/REW Time: Less than 5.5 min. with NV-E180

VIDEO

Television System: CCIR; 625 lines, 50 fields, PAL colour signal

Modulation System: Luminance; FM azimuth recording
 Colour signal; converted subcarrier phase shift recording

Input Level: VIDEO IN (PHONO); 1.0 Vp-p, 75 ohm, terminated

Output Level: VIDEO OUT (PHONO); 1.0 Vp-p, 75 ohm, terminated

RF Modulated; NV-J35A: VHF channel 0 or 1, 75 ohm, unbalanced
 NV-J35EA: VHF channel 2 or 3, 75 ohm, unbalanced

AUDIO

Input Level: AUDIO IN (PHONO); -10 dB, more than 50 kohm, unbalanced

Output Level: AUDIO OUT (PHONO); -6 dB, less than 1 kohm, unbalanced

Audio Track: 1 track (Normal-mono only)

Video Horizontal Resolution: Colour; more than 240 lines (SP)

Signal-to-Noise Ratio: Video; more than 43 dB (SP)
 Audio; more than 43 dB (SP)

Audio Frequency Response: 80 Hz-10 kHz (SP)

Operating Temperature: 5°C-40°C

Operating Humidity: 35%-80%

Weight: 4.8 kg

Dimensions: 380 (W)×82 (H)×345.5 (D) mm

Standard Accessories: 1 pc. DIN-DIN Coaxial Cable
 1 pc. Remote Controller
 2 pcs. "R6" size batteries
 1 pc. AC Mains Lead

Weight and dimensions shown are approximate.
 Specifications are subject to change without notice.