

HITACHI

C24W1TN - C28W1TN - C32W1TN - C24W410SN

WIDE SCREEN COLOUR TELEVISION

INSTRUCTION BOOKLET



HITACHI

Dear Hitachi Customer,

Congratulations on your purchase of the very latest 'state of the art' wide screen television from HITACHI. We pride ourselves on producing high quality televisions with outstanding picture and audio capabilities, coupled with Hitachi's reputation for superior reliability.

In the Main Operating Guide there is a fold out section on page 3. This page contains a numbered guide for the remote control handset. While following this manual, fold out this section, this will enable you to easily reference between the manual and the remote control handset.

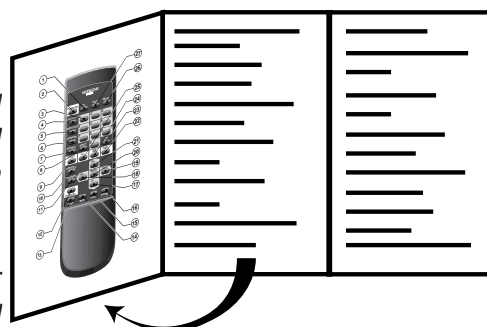

You should enjoy many years of trouble free operation from your TV. Take some time to read the Operating Guide thoroughly, and if you encounter any difficulty, firstly refer to the Trouble Shooting guide at the rear of this manual. If, in the unlikely event of a problem occurring on your TV, contact your dealer immediately. Please read the Guarantee carefully.

Use the boxes provided below to record your TV's Model and Serial N^o (these are found on the rating plate located on the rear of the TV). Also, record where and when you purchased this TV. This will speed any future queries you may have and should be used in all correspondence with Hitachi service centres.

Model:-

Serial N^o:-

Dealer/Store:-

Date Purchased:-

CONTENTS

Introduction & Contents	Page 2
Remote Control Handset Layout	Page 3
Remote Control Handset Guide	Page 4
TV Safety	Page 5
Battery Safety & Installation	Page 6
TV Installation	Page 7
General TV Controls Overview	Page 8
Automatic Tuning Procedure	Page 9-10
Manual Tuning Procedure	Page 11-12-13
Picture & Audio Controls	Page 14-15
Feature Menu	Page 16
Additional Features	Page 17
Wide Screen Modes	Page 18
External Equipment Connection	Page 19-20
Teletext & VCR Operation	Page 21
Trouble Shooting Guide	Page 22
Your Guarantee	Page 23
Technical Specifications	Page 24
Environmental Notice	Page 25

Handset Layout

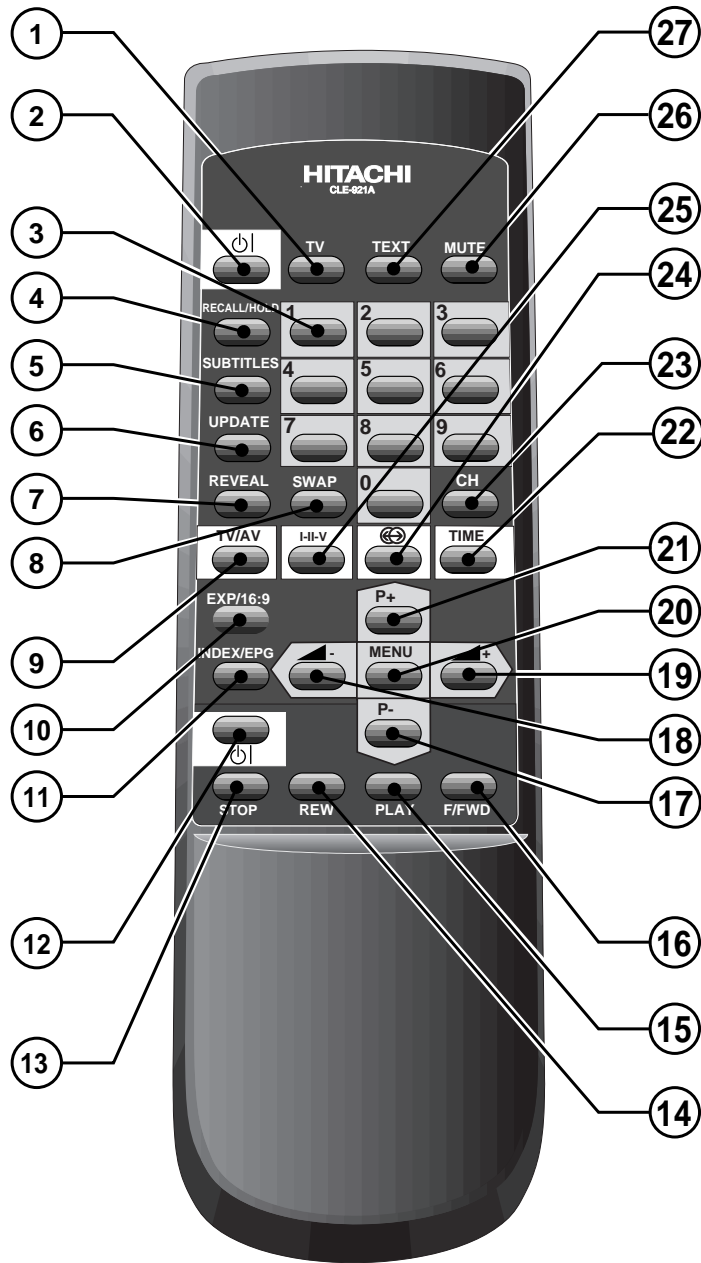

Handset Functions

The remote control handset supplied has several dual functions. These functions are mainly used for operations whilst in teletext mode. The Teletext modes and functions are in ****Bold Italic type*** and all functions are briefly explained below.

Button N ^o	Description	Function
1	TV Button -	This enables the viewer to return to normal TV operation.
2	Stand-by Button	Used to switch the TV on and off for short periods of time. Use ON/OFF button on TV for longer periods of inactivity (see environmental notes on page 25)
3	Buttons 0-9	Used for direct programme selection (enter a second digit within 2 seconds for programme numbers above 10 i.e. to obtain programme number 29 enter 2 and then 9). <i>Teletext 3 digit entry.</i>
4	Recall/ <i>Hold*</i>	Press Recall to view current TV status. <i>Press Hold to freeze Teletext pages.</i>
5	<i>Subtitles Button*</i>	<i>Allows the user to access a subtitle service directly (subject to Subtitle service broadcasting).</i> Also used to set various Wide Screen subtitle formats (see page 18).
6	<i>Update Button*</i>	<i>The Update button restores the TV screen whilst a Teletext page is searched.</i>
7	<i>Reveal Button*</i>	<i>Used whilst in Teletext mode to reveal hidden pages i.e. quiz pages etc..</i>
8	Swap Button *	In TV mode swaps between previous and current programme numbers. <i>In Teletext mode this feature allows the user to recall the last 4 Teletext pages.</i>
9	TV/AV Button	The TV/AV button allows the user to select either a TV or external source signal i.e. a camcorder etc.. <i>This button also has a colour coded teletext function</i> and OSD [†] function.
10	16:9/ <i>EXP*</i>	Used to select between Wide Screen formats. <i>Used to expand text pages.</i>
11	EPG/ <i>INDEX*</i>	<i>The INDEX function is used whilst in Fasttext mode and displays the magazine page on view.</i> The EPG function is not available on this model.
12	Stand-by Button	Please Note: The following VCR controls operate Hitachi VCR equipment only. Used to switch the VCR on and off for short periods of time.
13	Stop Button	Press to stop the VCR tape.
14	Rew Button	Press to rewind a VCR tape.
15	Play Button	Press to play a VCR tape.
16	F/Fwd Button	Press to fast forward a VCR tape.
17	*P-/Cursor Down	When in normal TV operation this button allows the user to step down programme numbers in sequence. In MENU mode this button is the cursor down key.
18	Vol-/Cursor Left	When in normal TV operation this button allows the user to reduce the TV volume. In MENU mode this button is the cursor left key.
19	Vol+/Cursor Right	When in normal TV operation this button allows the user to increase the TV volume. In MENU mode this button is the cursor right key.
20	MENU Button	The MENU button when pressed allows the user to access the TV's menu system.
21	*P+/Cursor Up	When in normal TV operation this button allows the user to step up programme numbers in sequence. In MENU mode this button is the cursor up key. <i>*The P+/P- buttons can also step forward or back a page whilst in Teletext mode.</i>
22	Time Button*	This button allows the user to display the current time on-screen, <i>also has a colour coded teletext function</i> and OSD [†] function.
23	CH Button	Allows the user to directly input known broadcasting CH or frequency numbers.
24	Stereo Button	Press to select between Stereo Normal and Stereo Wide modes, <i>also has a colour coded teletext function</i> and OSD [†] function.
25	Dual Language	This button allows the user to select a dual language function (subject to availability)and switches from Mono to Stereo reception, <i>also has a colour coded teletext function</i> and OSD [†] function
26	Mute Button	This feature allows the user to mute the sound temporarily.
27	<i>Text Button*</i>	<i>When pressed this button enables the Teletext service.</i>

† OSD (On Screen Display).



This television has been designed and manufactured to meet international safety standards, but like any electrical equipment, care must be taken if you are to obtain the best results and safety is to be assured.





DO read the operating instructions before you attempt to use the equipment.



DO ensure that all connections, (including the mains plug, extension leads and inter-connections between the pieces of equipment), are properly made and in accordance with the manufacturers instructions. Switch off and withdraw the mains plug before making or changing connections.



DO observe the manufacturers instructions when connecting extension leads to your TV. The fuse should be a 5 Amp fuse with the safety symbols  and  displayed. If you are in any doubt about the extension installation, please consult a competent electrician.



Should you require to replace the fuse in the moulded mains plug with a new fuse then please replace with one of the same value, type and approval as the original. Ensure the fuse cover is returned to its original position.



DO consult your dealer if you are in any doubt about installation, operation or safety of your equipment.



DO be careful with any glass panels or doors on equipment.



DO place your TV on a flat surface, or if supplied, the stand accessory.



DO NOT remove any fixed cover as this may expose dangerous voltages.



DO NOT cut off the fitted mains plug as it may contain a special radio interference filter, the removal of which could lead to impaired performance. If you wish to extend the lead, obtain an appropriate extension lead or consult your dealer.



DO NOT continue to operate the equipment if you are in any doubt about it working normally or if it is damaged in any way - switch off, withdraw the mains plug and consult your dealer.



IF you intend placing this TV into a cabinet or a wall alcove, please ensure there is at least a 100mm (10cm) gap to the sides, rear and top of the TV. This is to allow for adequate ventilation during your TV's operation.



DO NOT leave equipment switched on when it is unattended unless it is specifically stated that it is designed for unattended operation or has a stand-by mode. Switch off using the switch on the equipment and show your family how to do this. Make special arrangements for infirm or handicapped people.



DO NOT obstruct the ventilation of the equipment, for example with curtains or soft furnishings. Overheating will cause damage and shorten the lifespan of your equipment.



DO NOT use makeshift stands and **NEVER** fix legs with wood screws - to ensure complete safety, always fit the manufacturers approved stand or legs with the fixings provided according to the instructions.



DO NOT allow electrical equipment to be exposed to rain or moisture.



DO NOT place hot objects such as candles or nightlights on, or close to, equipment. High temperatures can melt plastic and lead to fires.



DO NOT listen to headphones at high volume, as such use can permanently damage your hearing.



NEVER let anyone, especially children, push anything into holes, slots, or any other opening in the case - this could result in a fatal electrical shock.



NEVER guess or take chances with electrical equipment of any kind - it is better to be safe than sorry!



DO NOT use equipment such as personal stereos or radios so that you are distracted from the requirements of traffic safety. It is illegal to watch television whilst driving.

Battery Installation

1. Remove the batteries from their packaging and identify the + and - polarity.
2. Remove cover of Remote Control Handset by pressing down on the cover marked  whilst pulling in the direction of the arrow shown.
3. Insert the batteries making sure the polarities are correct i.e. + to +, - to -.
4. Replace batteries with equivalent SUM-3, AA or IEC R6.
5. Discard old batteries safely, follow the Safety Guidelines below.

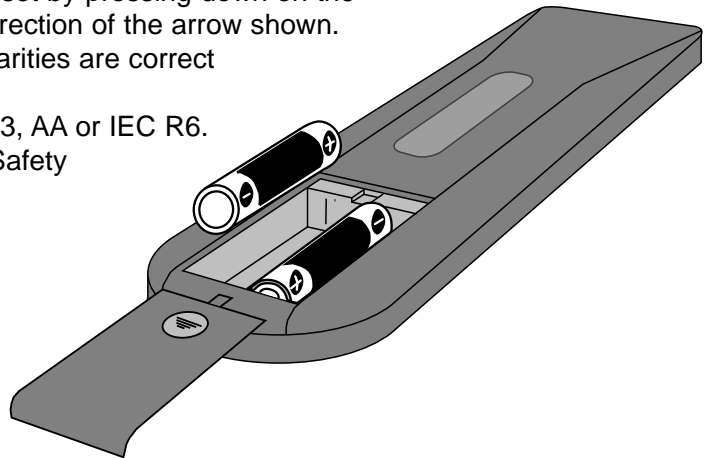

Battery Safety Guidelines

Used correctly, batteries are a safe and dependable source of portable power. However, problems can occur if they are misused or abused - resulting in leakage, or in extreme cases, fire or explosion. Here are some simple guidelines to safe battery use designed to eliminate any such problems.

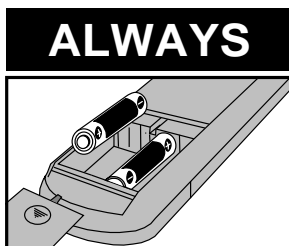

ALWAYS
Take care to fit your batteries correctly, observing the plus + and minus - marks on the battery and appliance. Incorrect fitting can cause leakage, or in extreme cases, fire or explosion.

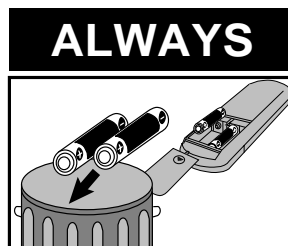

ALWAYS
Replace the whole set of batteries at one time, taking care not to mix old and new batteries of different types, since this can result in leakage, or in extreme cases, fire or explosion.

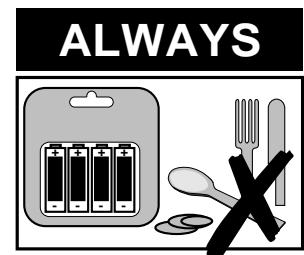

ALWAYS
Store unused batteries in their packaging and away from metal objects which may cause a short circuit resulting in leakage, or in extreme cases, fire or explosion.



ALWAYS
Remove dead batteries from equipment, and all batteries from equipment that is to be left for long periods of time without any use. Otherwise the batteries may leak and cause damage.

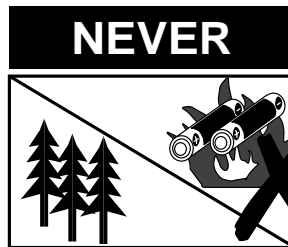

NEVER
Never dispose of batteries in fire as this can cause an explosion. Respect the environment - always dispose of batteries in an environmentally friendly manner.

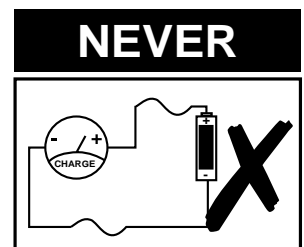

NEVER
Never attempt to recharge ordinary batteries, either in a charger or by applying heat to them. They may leak, cause fire or even explode. Rechargeable NiCad batteries and chargers can be purchased from any good 'High Street' electrical retailer.

TV Installation

Before installing your TV please read the following important notes:

If you intend placing this TV into a cabinet or a wall alcove, please ensure there is at least a 100mm (10cm) gap to the sides, rear and top of the Television. This is to allow for adequate ventilation during TV operation.

Don't allow soft furnishings such as curtains to be draped over the TV whilst in operation.

Never place the TV on to a carpet during normal operation - this could obstruct ventilation slots on the base of the TV. Always place the TV on a flat surface, or if supplied, the stand accessory.

Failure to observe the above guidelines could result in serious overheating of your TV, or in extreme cases, even fire.

Step 1.

Connecting your TV to the mains socket.

(Please read the Safety Notes on page 5 with reference to unattended operation).

Insert Plug and
Switch on

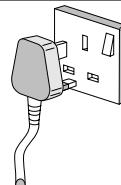

Step 2.

TV only installation.

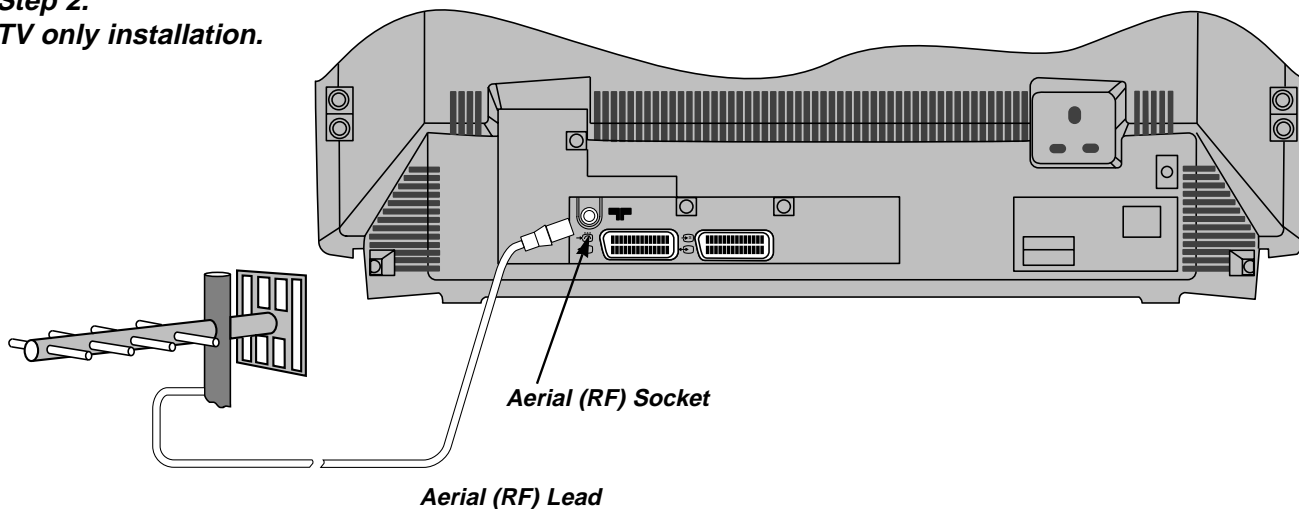

Step 3.

Installation via a VCR.

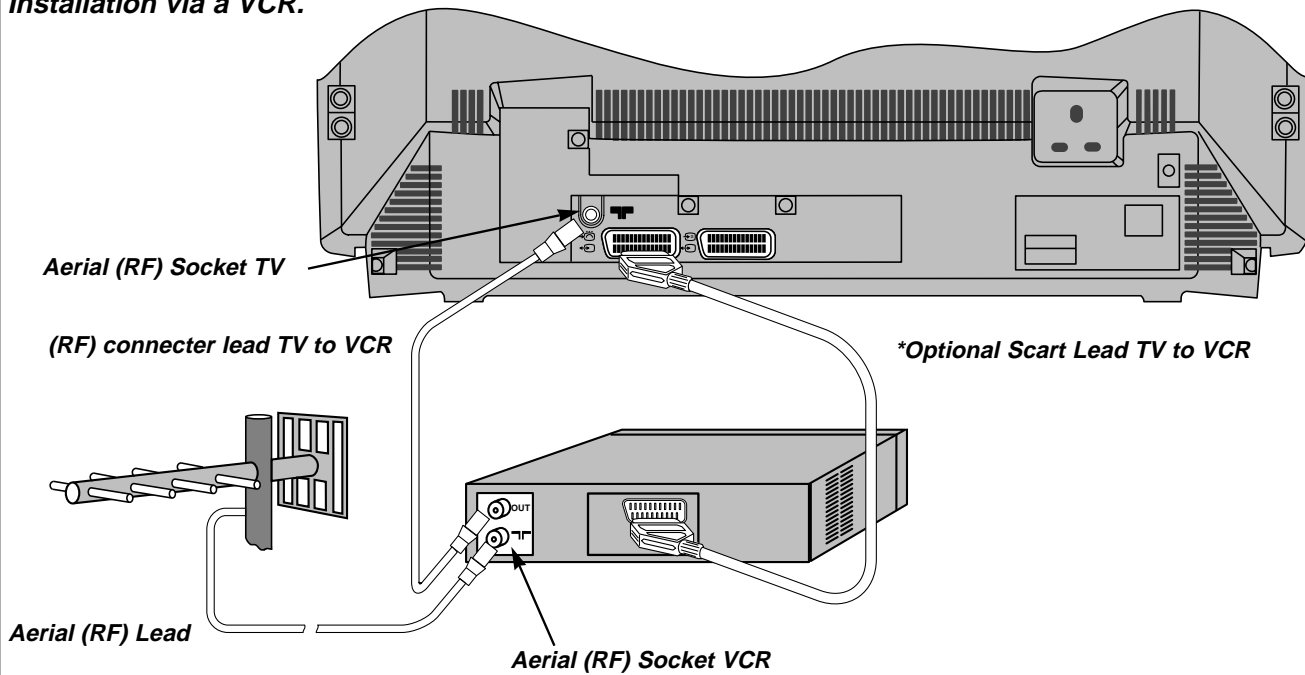

*A scart lead should be fitted between your TV and VCR to enhance your picture and sound quality. Scart leads are essential if you have a stereo TV and VCR and wish to obtain stereo sound from your equipment. These leads can be purchased from your Hitachi dealer or any good 'High Street' electrical retailer.

TV Controls Overview

FRONT CONTROL PANEL

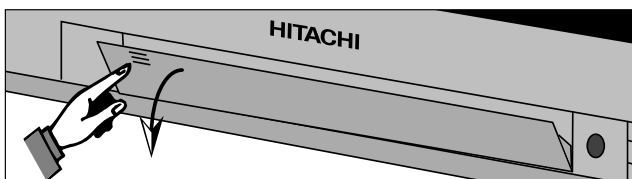

Access to the front control panel is gained by pushing the door in and releasing. The front control panel contains items such as the Headphone socket, Audio/Video sockets, MENU button, Programme +/- and Volume +/- buttons. Also located on the front are the ON/OFF button, Infra Red Lens and TV Mode Light.

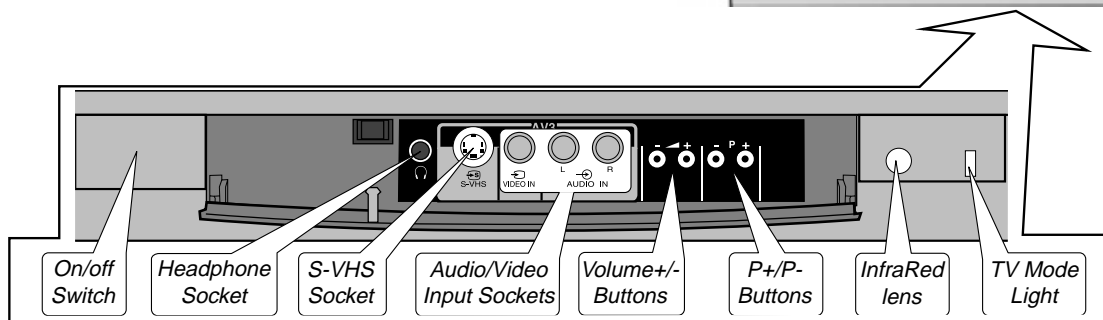

REAR CONNECTING SOCKETS

The rear of your TV contains an aerial RF input and two scart sockets, AV1 and AV2. The RF/ aerial socket is permanently connected to an RF source i.e. an aerial antenna (shown on Page 7). The scart sockets are used to connect external equipment such as VCR's, Satellite Receivers / Decoder etc. Connection of this equipment is explained in greater detail in the "EXTERNAL EQUIPMENT CONNECTION" section.

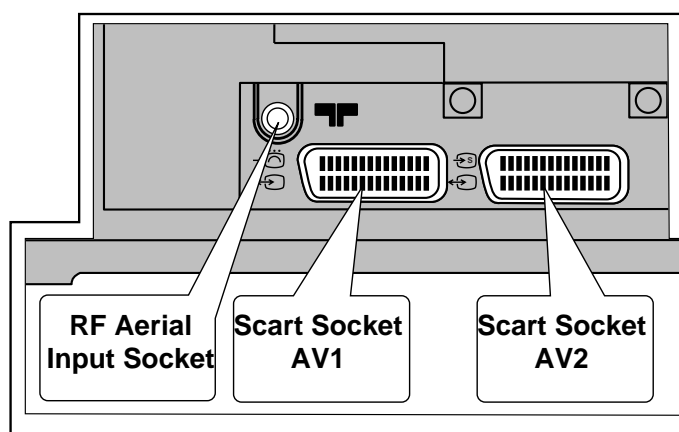
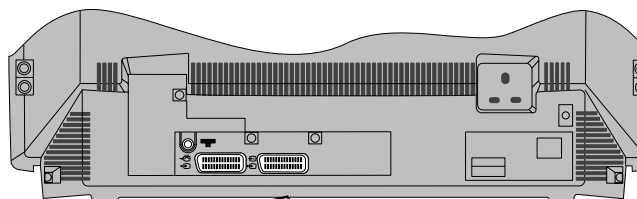

SWITCHING ON

To switch your TV on, press the ON/OFF button shown above. If the TV fails to display anything on the screen, but the red TV mode light appears bright, then the TV is in Stand by mode. Press the Stand by button on your handset (key 2) to activate the TV. The red TV mode light will then dim and you should allow the TV a few seconds for a picture to appear.

Automatic Tuning Procedure

NOTE: Make sure the Handset foldout section (Page 3) is extended out for easy referencing.

To automatically tune this TV to your local broadcasting stations follow the step by step guide below. Once the TV has found all your local stations, they are then automatically assigned into the following order **1. BBC1; 2. BBC2; 3. ITV; 4. CH4/S4C; 5.CH5 (subject to availability); 6. Cable / Satellite broadcasts.**

Alternatively, if you are familiar with local broadcasting frequency or CH numbers, then these can be entered manually. Please refer to the Manual Tuning Procedure section of this manual.

IMPORTANT NOTE: If you have a VCR or a Satellite receiver connected to this TV please ensure that they are switched on before Autotune commences. In the case of a VCR, insert a pre-recorded tape and begin playback of your equipment. With a Satellite receiver, select SKY NEWS. These measures ensure your equipment is tuned in during the AUTOTUNE procedure. (satellite equipment installation is explained in the "EXTERNAL EQUIPMENT CONNECTION" section).

Press and **HOLD** the MENU key (20) on your handset until the menu right (top) appears.

Highlight **INSTALL** using cursor keys 17 or 21 (if **INSTALL** is not shown follow step above once more).

Press cursor key 18 or 19 to select **INSTALL**. The **INSTALL** menu (centre right) is shown.

If language setting is incorrect, use cursor keys 17 or 21 to highlight **LANGUAGE**, and select using cursor keys 18 and 19.

Use cursor key 17 or 21 to highlight **AUTOTUNE**.

Use either cursor key 18 or 19 to begin **AUTOTUNE**.

To ensure the **INSTALL** option is displayed the MENU key (20) must be held for approximately 5 seconds.

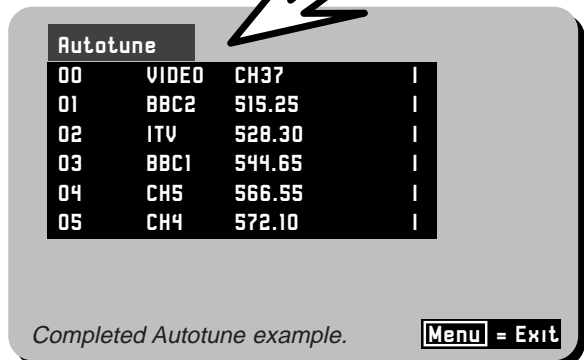
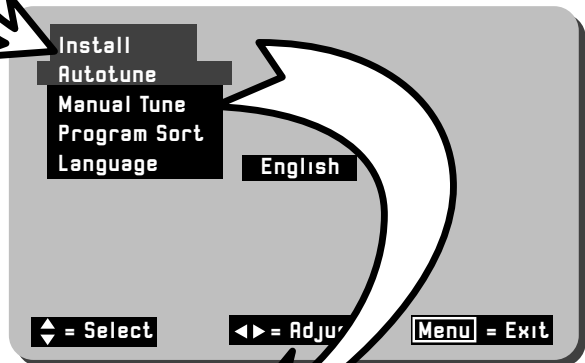
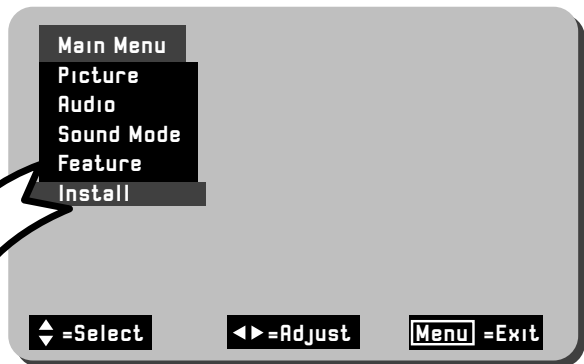

Automatic Tuning cont.

Program Sort

The PROGRAM SORT system allows the user to swap programme numbers from one location to another. If necessary follow the Guide below.

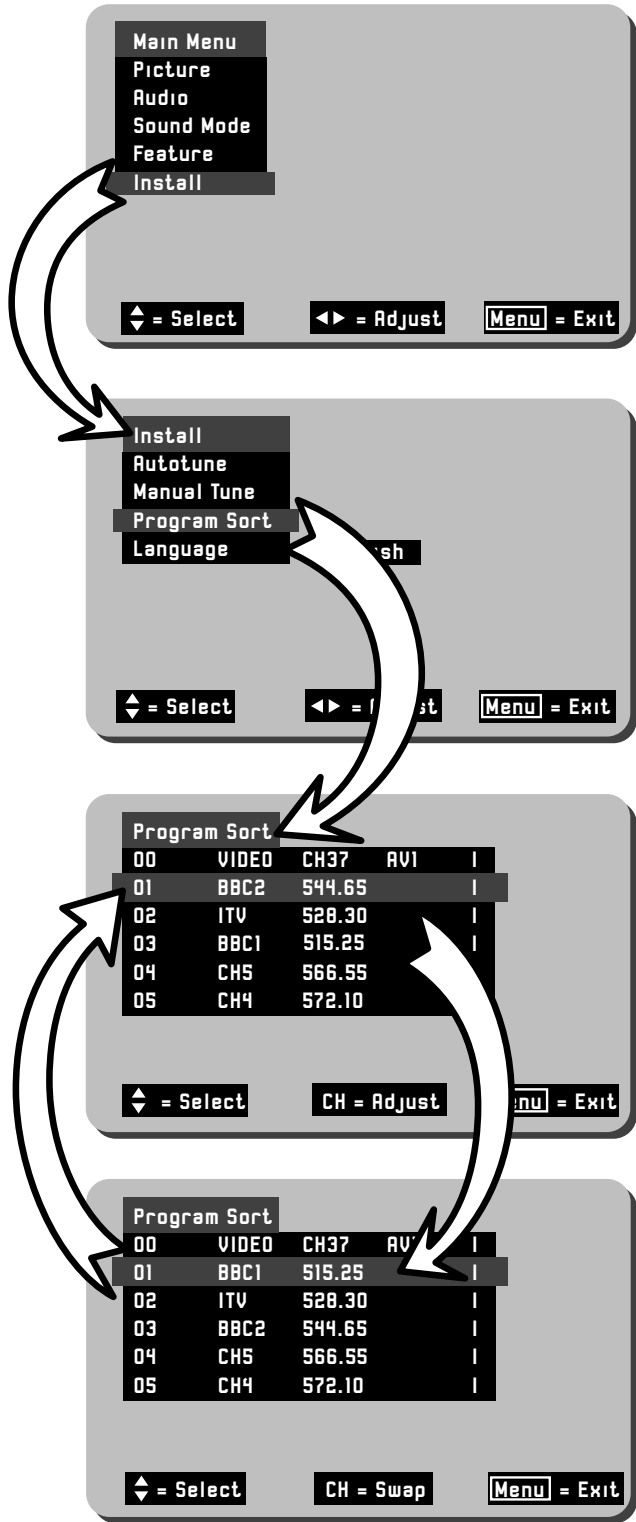
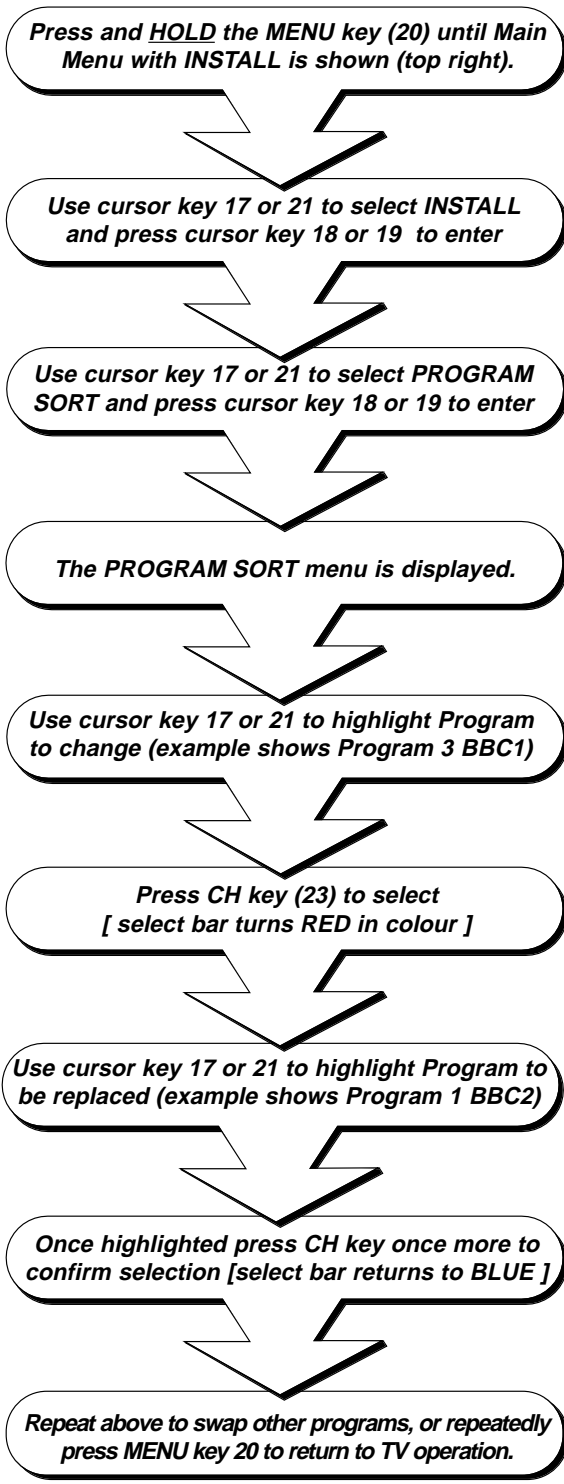

In this example BBC2 on Program 1 has been selected so that it may be swapped with Program 3 (BBC1).

Manual Tuning Procedure

If desired, you may manually tune this TV. There are several methods of Manual Tuning, these include Search Tuning / Fine Tuning and Frequency or CH manual input (this requires you to know your local broadcasting frequency or CH number). This section will also deal with items such as assigning AV sockets to program numbers and Program Naming.

Search Tuning / Fine Tuning This section deals with locating broadcasting stations using the Search Tuning and combined Fine Tuning facility. Fine Tuning may be required after Search or Automatic Tuning is complete.

Press and **HOLD** the **MENU** key (20) on your handset. The **Main Menu** (top right) is displayed.

Select **INSTALL** and press cursor keys 18 or 19 to enter. The **INSTALL** menu is displayed.

Select **Manual Tune** and press cursor keys 18 or 19 to enter **Manual Tune** menu.

The **Manual Tune** menu is displayed (bottom right).

Use cursor keys 17/18/19 and 21 to highlight frequency bar of programme N° to **Search Tune**.

Press **CH** key (23) to select [bar turns RED] and press cursor keys 18/19 to begin **SEARCH TUNE**.

When a broadcast is found either repeatedly press the **MENU** key (20) to store and exit to TV

OR

To continue **Search Tune** simply press cursor keys 18/19, the TV will start searching once more.

To **FINE TUNE** press cursor keys 17 or 21 until the picture becomes clear.

When complete repeatedly press the **MENU** key (20) to exit, or repeat above to **Search/Fine Tune** other program numbers if necessary.

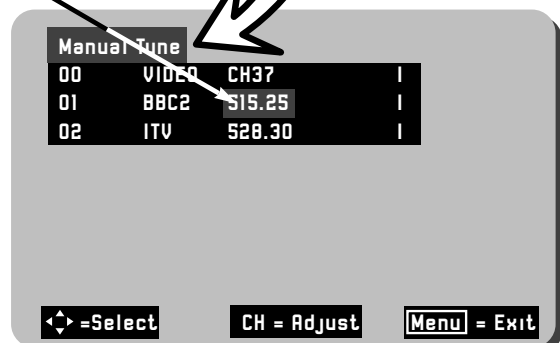
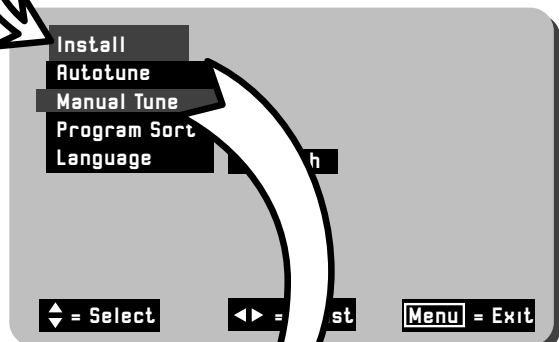

Manual Tuning cont.

Entering Known Frequencies

Broadcasting stations transmit the signal to your TV on a particular defined frequency i.e. 525.25MHz. These frequencies can be entered manually if known, and you can obtain this information by calling your local operator. In addition to frequency transmission a corresponding CHANNEL N^o is also used i.e. CH34, and this too can be directly input to your TV if known. (The S-- number has no function on this TV).

Press and **HOLD MENU** key (20) and select **INSTALL**.
Select **MANUAL TUNE** from **INSTALL** menu.

Use cursor keys 17,18, 19 or 21 to highlight the frequency of the program number you wish to enter.

Press the **CH** key (23) on your handset once, the column changes **RED** to indicate selection.

Repeatedly press **CH** key to select **CH-** or **---**, and enter the known number using 0-9 keys.

Once the number has been entered, press the **MENU** key once more and the display turns **BLUE**. This is now stored. Press **MENU** to exit.

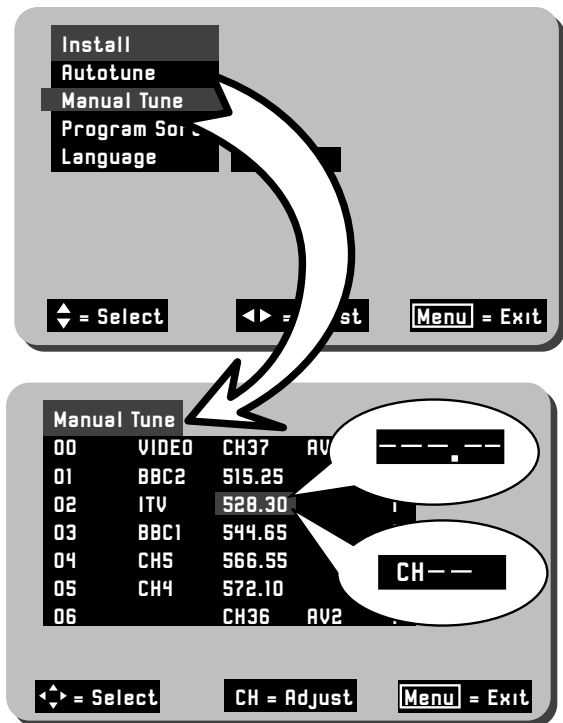

Assigning AV Prog. N^os

When AV sockets are commonly used, for example, if you view camcorder recorded events frequently, then we suggest assigning a dedicated program number on your TV. This can be any program number that has not already been assigned. Follow the step by step guide below.

Press and **HOLD MENU** key (20) and select **INSTALL**.
Select **MANUAL TUNE** from **INSTALL** menu.

Use cursor keys 17,18, 19 or 21 to highlight the **AV** column of the program number you wish to assign.

Once highlighted press the **CH** key (23) and select between each AV mode using cursor keys 18 or 19.

Repeat above to enter other AV sockets or repeatedly press **MENU** key (20) to store and exit to TV mode.

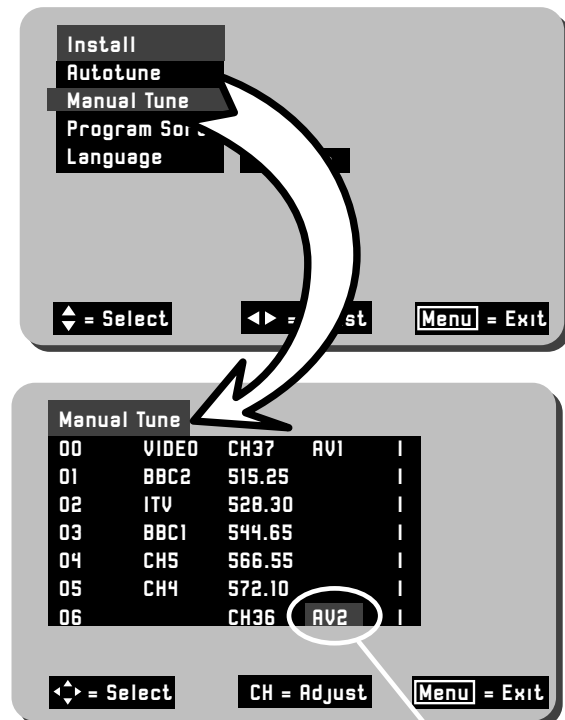

AV2 assigned to Program 7

Manual Tuning cont.

Program Naming

After Tuning in, most broadcasting station names appear on screen i.e. BBC1, BBC2, ITV etc.. However, you may change or add program names whenever you desire. To add or change program names follow the simple step by step guide below.

Press and **HOLD MENU** key (20) and select **INSTALL**.
Select **MANUAL TUNE** from **INSTALL** menu.

Use cursor keys 17,18, 19 or 21 to highlight the
Program Name you wish to assign or change.

Press the **CH** key (23) [the first digit will blink], now use
cursor keys 17/21 to scroll through all the characters.

Once the first character has been entered select
next digit using cursor key 19 and repeat above step.

You may use up to 5 characters for any one
Programme Name. Press **MENU** (20) key to store.

Repeat above steps to assign other Program Names
or repeatedly press **MENU** key (20) to exit to TV mode.

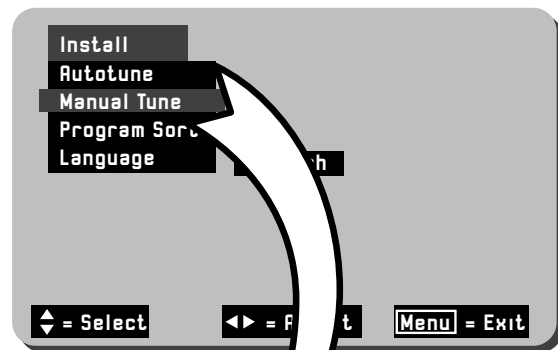

When selected the character will blink on and off.

Picture and Audio Controls

Picture settings are controlled via the TV's on board Menu system. These levels have already been preset at the factory and should require no adjustment. However, your personal viewing preferences may vary from these settings and alteration should be performed as follows:-

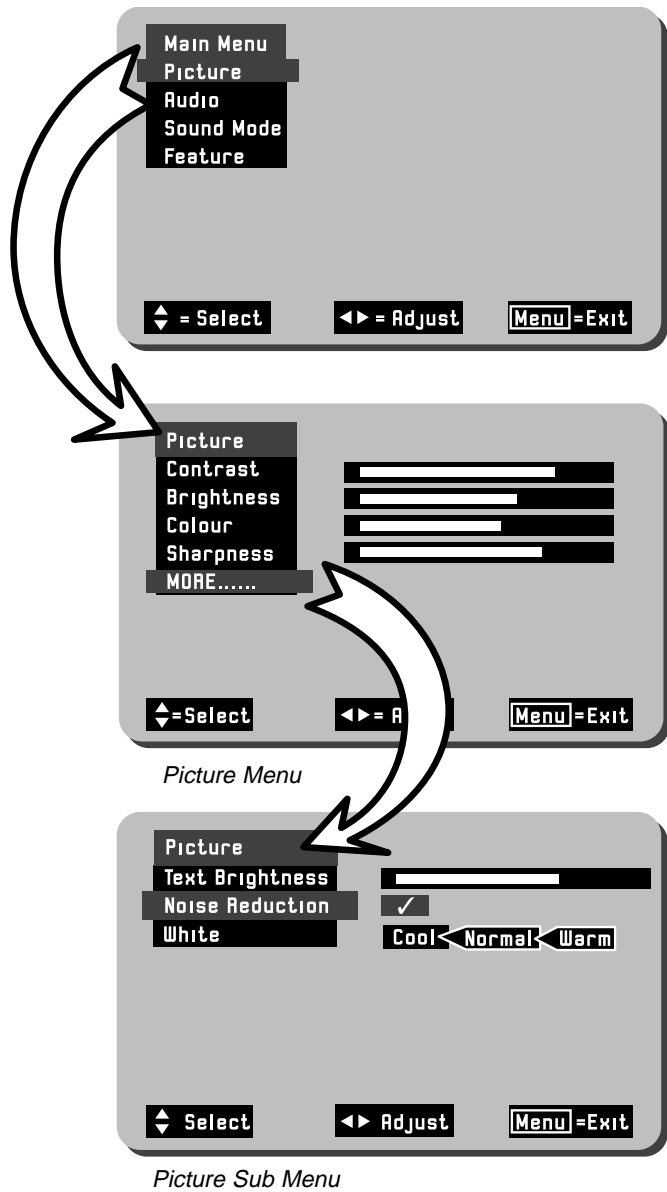
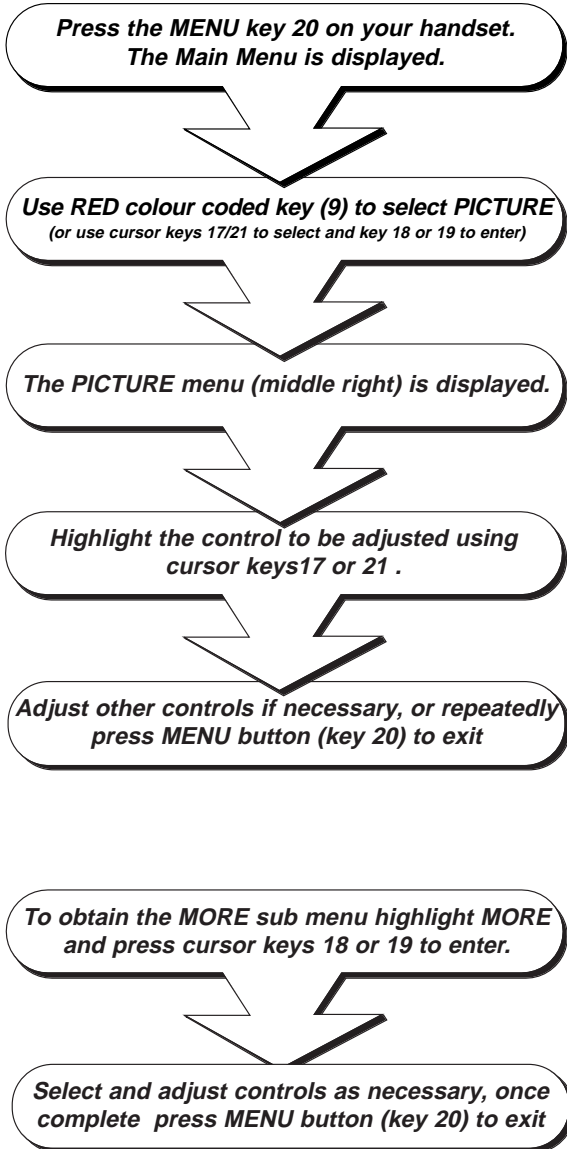

Function Controls

CONTRAST:

COLOUR:

BRIGHTNESS:

SHARPNESS:

*HUE:



*(Hue control appears on-screen only if an NTSC signal is received via the AV sockets).

More Functions

TEXT BRIGHTNESS : This function allows the user to adjust the text brightness of On Screen Display windows and Teletext pages.

NOISE REDUCTION :Noise Reduction improves picture quality when a signal becomes weak or when viewing poorly recorded VCR tapes. When selected a ✓ is displayed.

WHITE: This feature controls the colour temperature displayed on the picture tube.

Picture and Audio Controls

The Sound Menu is accessed via the TV's on-board MENU system, and allows the user to control such features as Volume, Bass, Treble, Balance and Bass Boost. These settings have already been preset at the factory, however, your personal listening tastes may differ from those set. Please follow the guide below for adjustment and setting.

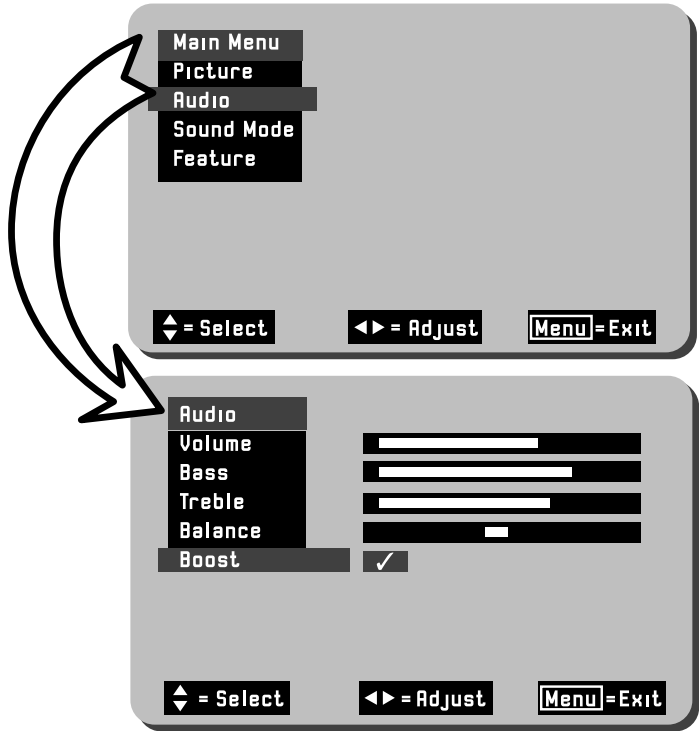
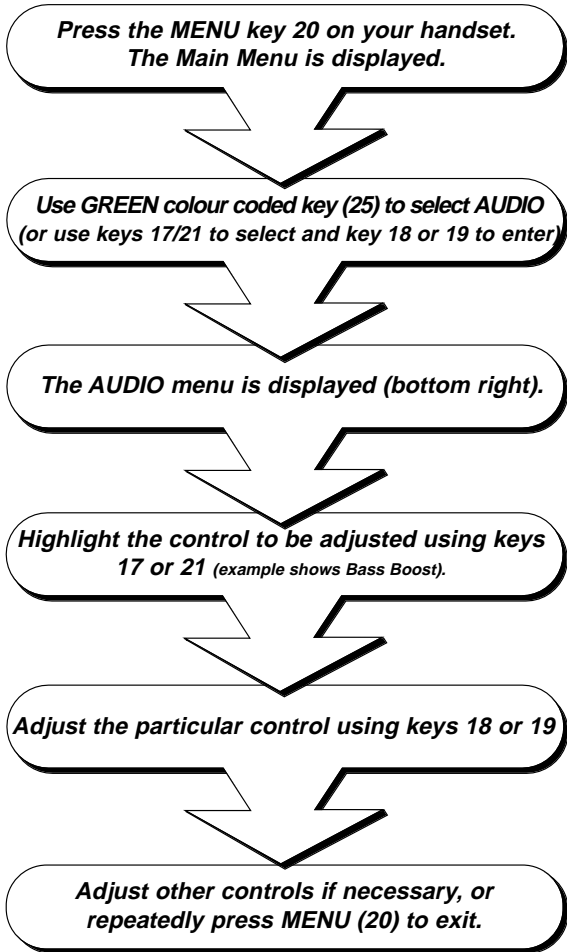

Function Controls

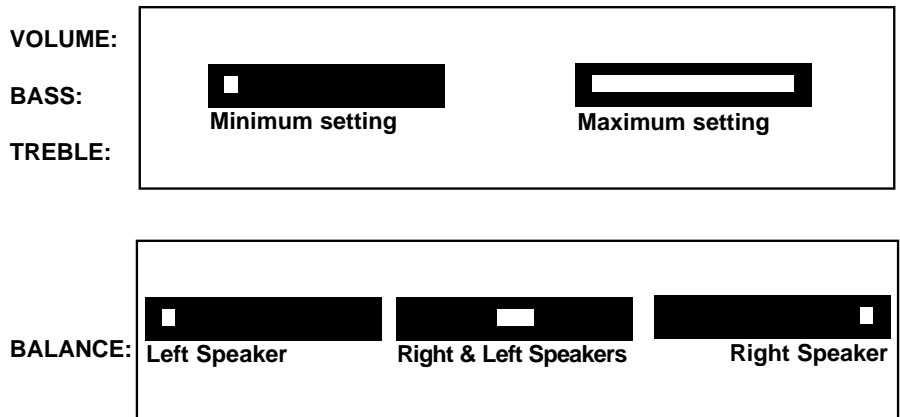

BASS BOOST: When selected a ✓ is displayed.

Feature Menu

Solid Background

The Solid Background feature controls the appearance of the OSD (On Screen Display) window environment, with either a solid or transparent appearance to the OSD. There are two modes to select from and these are simply ON and OFF. Follow the guide below.

Press the MENU key (20) on your handset.
The Main Menu is displayed.

Use BLUE colour coded key (22) to select FEATURE
(or use cursor keys 17/21 to select and cursor key 18 or 19 to enter)

Select Solid Background and adjust the controls
ON or OFF with cursor keys 18 and 19.



With Solid Background deselected the OSD window becomes transparent (example shown above), allowing you to view the TV picture behind the OSD. With Solid Background selected the OSD window becomes solid. A ✓ is displayed when Solid Background is selected

Scart2 Auto Mode

This feature is used to set the condition of Scart 2 Audio/Video input socket. If, for example, you regularly connect external equipment such as S-VHS (Super VHS) Video recorders or camcorders to AV2, then the TV can be set to SAV mode to accommodate such equipment. Standard AV mode can also be set if desired.

Press the MENU key (20) on your handset.
The Main Menu is displayed.

Use BLUE colour coded key (22) to select FEATURE
(or use cursor keys 17/21 to select and cursor key 18 or 19 to enter)

Select Scart2 Auto Mode and adjust the controls
between AV and SAV with cursor keys 18 and 19.

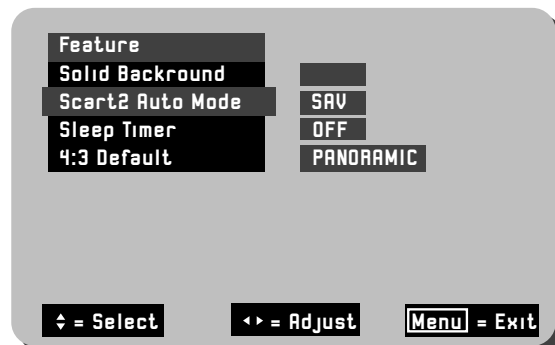

Sleep Timer Function

The Feature Menu also incorporates a Sleep Timer Facility. This allows the user to input a set amount of time before the TV automatically shuts down in to Stand by mode. The amount of time is input in 5 minute intervals, to a maximum of 120 minutes (2 hours).

Press the MENU key (20) on your handset.
The Main Menu is displayed.

Use BLUE colour coded key (22) to select FEATURE
(or use cursor keys 17/21 to select and cursor key 18 or 19 to enter)

Select Sleep Timer and enter the time value
with cursor keys 18 and 19.

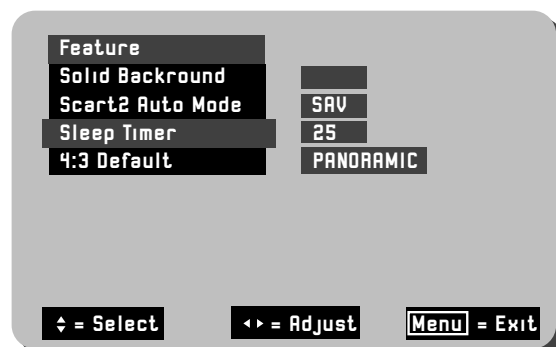

An example of the Sleep Timer function with 25 minutes entered is shown. **NOTE:** In addition to the Sleep Timer function, if the TV does not receive a signal for a period of 10 minutes the TV will automatically power down into Stand by mode.

4:3 Default

The 4:3 Default setting allows the user to set which screen mode the TV defaults to when the AUTO function is selected but WSS (Wide Screen Signalling) is not transmitting. This allows the user to select between the various Wide Screen modes as a default. Refer to "WIDE SCREEN MODES" section.

Select Feature as described above,
then highlight 4:3 Default
select screen mode with cursor keys 18 and 19.

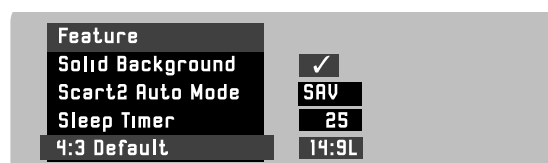

NICAM Features

In addition to the standard features found, your TV also has NICAM sound capabilities. NICAM transmitted signals provide stereo sound whilst viewing the TV in NICAM mode, thus giving the user even greater listening pleasure. The TV also provides 16:9 (Wide Screen Format) viewing capabilities, together with automatic wide screen detection software built in.

Nicam Features

The Nicam facility features two modes which provide the viewer with various sound effects. These features are activated by pressing the  key (N°24) on the handset. When repeatedly pressed the TV will cycle through each mode and will display a particular on-screen symbol. The various modes and on-screen identification is explained below.

Stereo This effect produces NICAM digital stereo sound from the TV. Use this mode for the majority of TV viewing. When selected the STEREO symbol is displayed in the top right hand corner of the TV screen as shown.



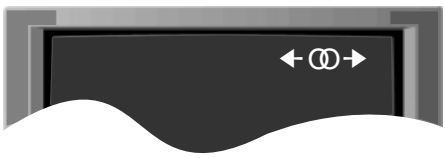

Wide Stereo This effect enhances NICAM digital stereo by forcing a wide area of sound from the TV. Use this mode when viewing action movies or sports events to obtain spatialising acoustic performance. When selected the symbol shown below appears at the top right hand corner of the screen.



Monaural In monaural mode the TV transmits a single sound source. The TV will automatically select this sound when a mono signal is found. Some stereo signals can become poor in adverse weather conditions, and mono should be selected to avoid poor sound. Use the **I-II**  key (N°25) to switch to mono (the symbol below appears when switched).



Pseudo Stereo Pseudo stereo creates an ambient sound from mono signals imitating that of stereo sound. Use the  key (N°24) to select Pseudo Stereo. When selected the symbol shown will appear in the top right hand corner of the screen.



Wide Screen Modes

The various screen modes below and on page 18 are available on this model. Each of these modes are accessed using the 16:9 button (10) on your handset



example 1



example 2

AUTO

Auto mode automatically detects various screen formats that are transmitted in either conventional (4:3) or wide screen (16:9/14:9). After detecting which signal is being transmitted the TV will automatically switch to the correct screen ratio.

In example 1 (left) a 4:3 conventional picture format is shown, note the black bars to the sides of the screen, this is consistent with screen compression. 4:3 mode can also be manually selected if desired.

Example 2 (left) illustrates a 16:9 Wide Screen picture format. This type of picture fills the entire TV screen. The 16:9 mode can also be manually selected if desired.

Hitachi recommend that AUTO is selected for the majority of TV viewing.

NOTES: The function of the AUTO mode is dependent on whether the Wide Screen Signalling (WSS) is transmitting, check with your local operator for availability.

When WSS is not active the picture mode will default to the Feature settings

Wide Screen Modes cont'



example 3

AUTO cont'

AUTO mode can also detect 14:9 ratio signals, when this mode has been selected thin black bars appear to the sides of the screen (example 3).

NOTE: Other screen formats may be transmitted by certain broadcasters, these are 14 x 9 True Wide Screen and 16 x 9L/14 x 9L with subtitles. Your TV is able to detect these formats and adjust the set automatically (subject to WSS transmitting).



example 4

PANORAMIC

Panoramic mode emulates that of a Wide Screen broadcast for 4 x 3 transmissions. This is achieved by maintaining the proportions of the centre of the screen while extending the images on the sides of the screen (example 4).

MANUAL SETTINGS Some modes can also be manually selected if some pictures appear distorted or stretched, or subtitle information becomes lost. Follow the guide below to apply the correct setting.



example 5

16 x 9L

The 16:9 Letterbox mode is used to expand a 16:9 letterbox style picture so that it uses the full screen to display the picture. Letterbox type pictures are identifiable by the black bars that appear on the top and bottom of the screen and some objects appear stretched (see example 5). Once selected, the 16:9L mode displays the picture as example 2.



example 6

14 x 9L

When viewing pictures in the 14:9 Letterbox mode (example 6) thin black bars appear at the top and bottom of the screen, and images become slightly elongated. By selecting 14:9L mode the user can expand the TV picture to display more of the screen (see example 3 above).



example 7

If viewing movies or programmes containing screen subtitles whilst in 16 x 9L or 14 x 9L modes, the subtitle may become lost to the bottom of the screen. To overcome this problem, simply press the SUBTITLE button (5) once. The SUBTITLE feature compresses the bottom of the screen allowing the subtitles to be viewed, as in example 7. If, however, you wish to view Teletext subtitles a further press of the SUBTITLE button is required, this will then restore the screen to its original setting.

NOTE: Whatever Wide Screen mode was set before the TV is switched off will be the same condition when it is switched back on.

The references to the Wide Screen modes are purely for guidance purposes only, your preferences may vary to those listed.

External Equipment Connection

Your TV has various input sockets for external equipment such as Video Cassette Recorders, Satellite Receiver/Decoder, Camcorders, Computer Equipment etc.. Equipment that is connected temporarily i.e. Camcorders can be connected via the front control panel input sockets. However, equipment such as VCR's and Satellite IRD's, that are more or less permanently connected to your TV, are connected via the AV1 or AV2 scart sockets on the rear of the TV.

CAMCORDER CONNECTION: Connecting a camcorder to your TV is simple. Firstly, identify the type of camcorder and it's connecting plugs. If it is a standard 8mm type camera then it is likely to have 'RCA' type sockets. If, however, you have S-VHS or Hi8 type camera then this may have a S-VHS/Hi8 plug and will have to be placed in the corresponding S-VHS/Hi8 socket on the TV. Open the front control panel door on the TV, and connect your equipment as shown in the illustration below. Switch your TV on, and repeatedly press the TV/AV button (N^o9) on your handset until AV3 is displayed on-screen. Now begin

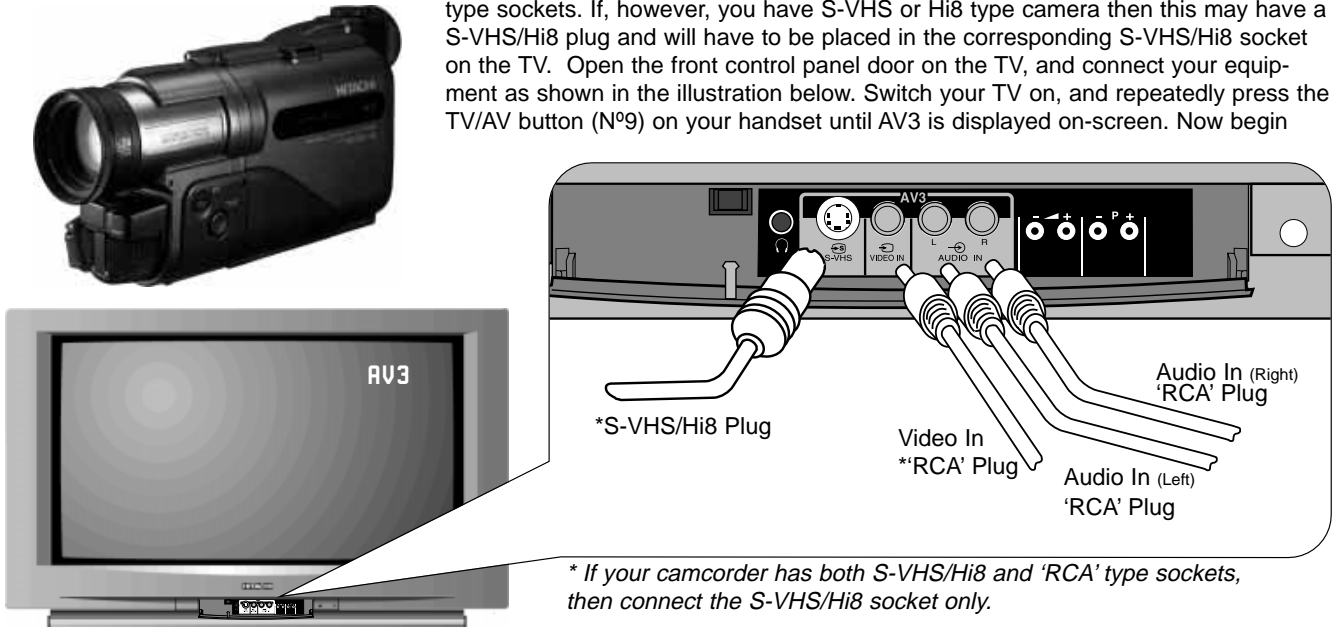

COMPUTER EQUIPMENT: If computer equipment is to be connected to this TV, use AV1 as the RGB input socket located on the rear of the TV.

PLEASE NOTE: Prolonged use of computer equipment or games on this TV may cause permanent damage to your picture tube. To avoid such damage, reduce the brightness and contrast to an acceptable minimum level and limit the duration of equipment operation.

SATELLITE CONNECTION: There are two basic methods of connecting a satellite system to your TV. Method 1 explains connection of satellite equipment directly to the TV, where as Method 2 refers to connection via a VCR.

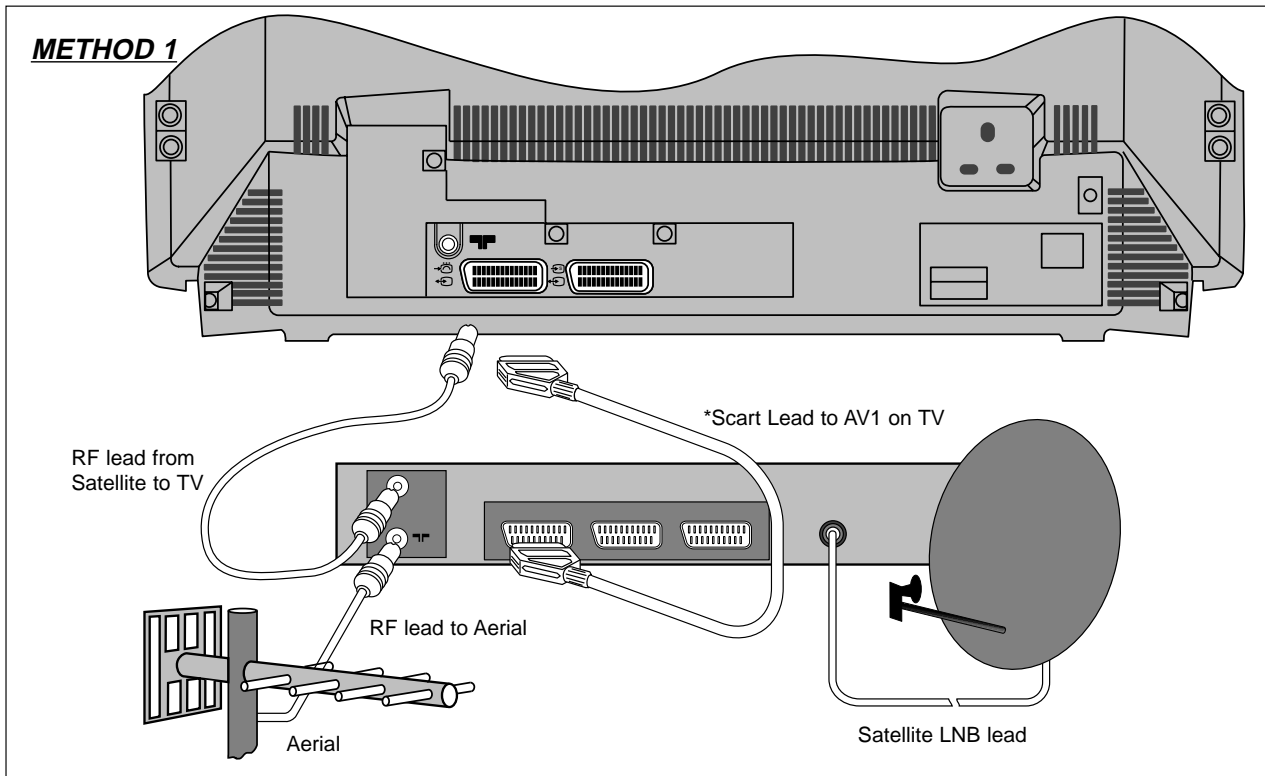

External Equipment Connection

METHOD 2

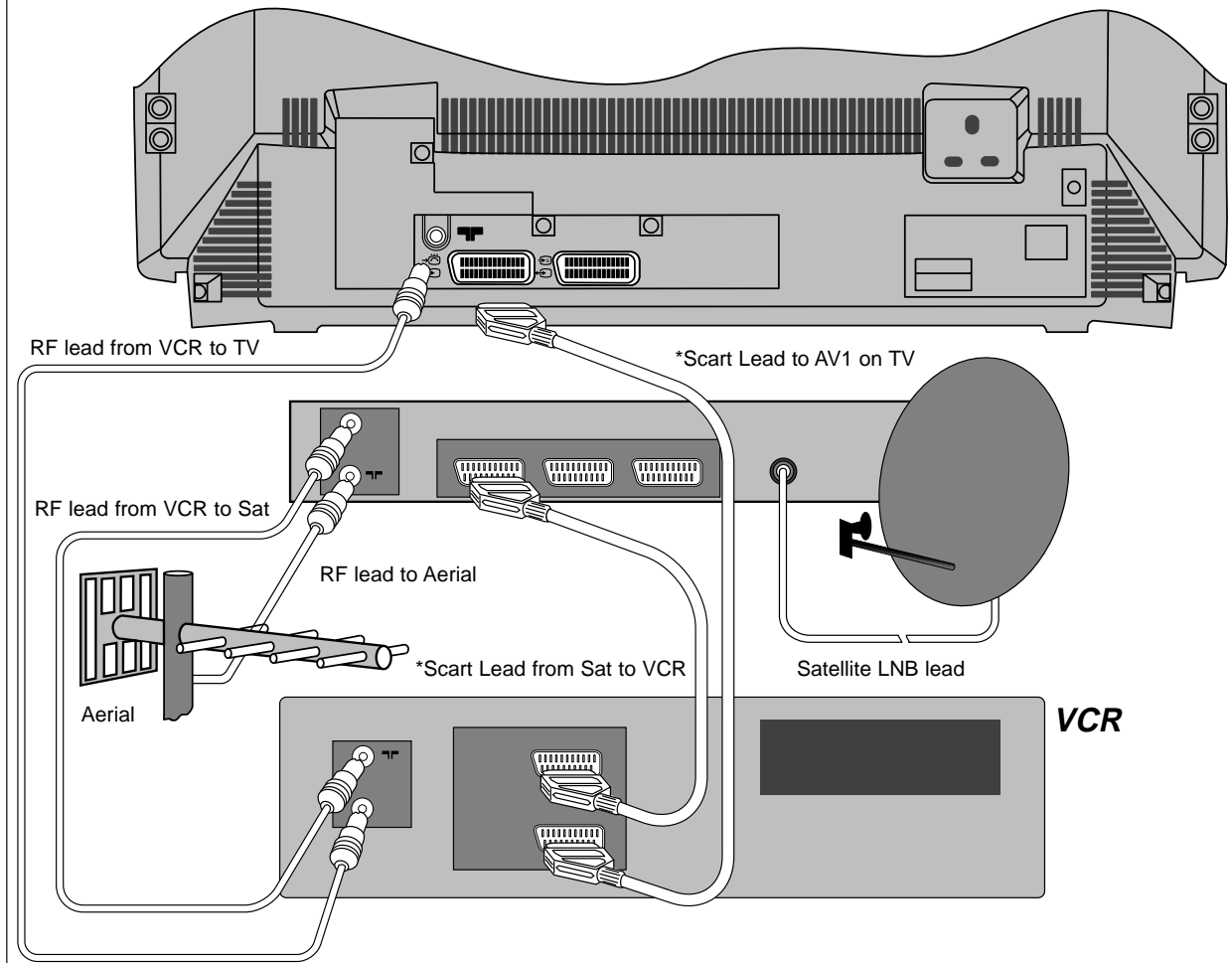

NOTE: S-VHS video equipment should be connected to the AV2 Scart socket located on the rear of the TV. A dedicated program number may then be assigned to AV2, allowing you easier access to view external equipment broadcasts. How to assign AV sockets to dedicated program numbers is explained in the “**MANUAL TUNING**” section. Alternatively, repeatedly press the TV/AV button (N°9) on your handset until AV2 is displayed on-screen. Now begin playback operation of your equipment.

HEADPHONE CONNECTION:

To use headphones with this TV, simply open the front control cover door and insert the headphone jack plug (3.5mm) into the corresponding socket marked . The TV sound will then be switched to the headphones.

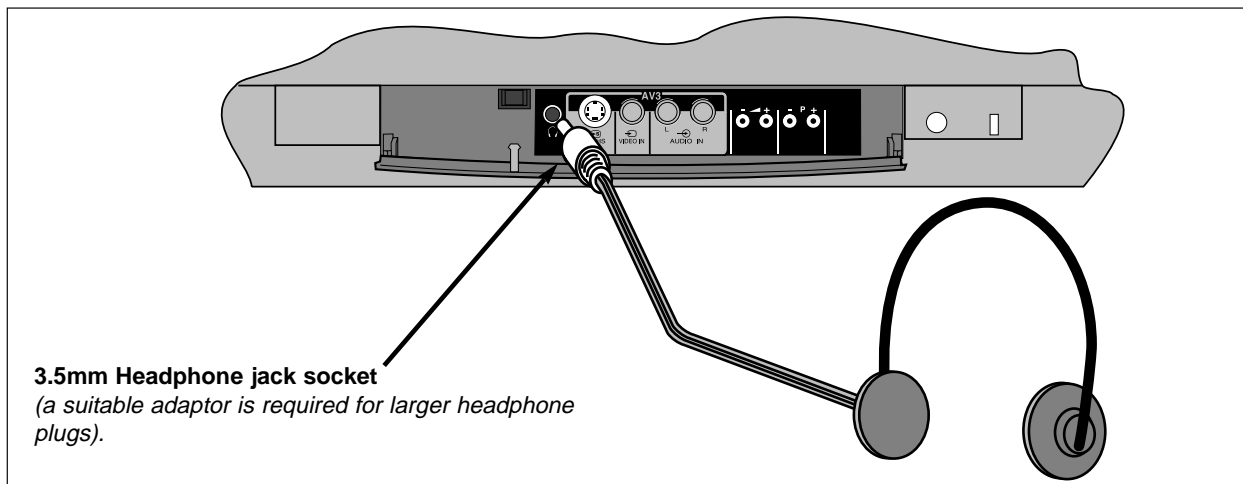

Teletext Operation

Teletext operation is entered by pressing the TEXT button (key 27) on your handset.

A page similar to the one shown on the right will appear. The main page contains numbered topics that are accessed by entering the corresponding three digit code on your handset (keys 3).

In addition to the above system, at the bottom of the page there are four colour coded popular topics i.e. TV Guides, Weather, Sport etc., however, these may vary between each broadcasting station.

To access these topics simply press the corresponding colour coded keys on your handset (keys 9, 22, 24 and 25).

By pressing the P+ or P- keys (17 and 21) you may step up or down a page respectively.

If a mistake occurs while entering a number then simply re-enter the desired number.



P100 CEEFAX 2 100 Wed 19 Mar 15:49/06

CEEFAX

CEEFAX AT-A-GLANCE PRESS HOLD

NEWS HEADLINES	101	LOTTERY	555
NEWS INDEX	102	BACKBEAT	560
ELECTION	97	FREETIME	570
NEWS EXTRA	140	GARDENING	573
CITY	BBC2	COOKBOOK	580
SPORT	300	ON THE BOX	590
WEATHER	400	TV GUIDE	600
TRAVEL	430	TV LINKS	615
CBBC INDEX	500	RADIO	BBC1 640
SUB ZERO	501	EDUCATION	BBC2 640
NEWSROUND	510	READ HEAR	BBC2 640
SHOWTIME	520	COMMUNITY	BBC2 650
SWITCHED ON	540	RACING	660

NEWS EXTRA...NEWS EXTRA...NEWS EXTRA
Home 141 World 142 Politics 143
News Heads Sport TV/Radio Weather

The 4 Fastext Topics are shown on the bottom of the screen

FAVOURITE PAGE OPTIONS

The TV is capable of storing up to 4 favourite pages. These pages could be your favourite sport or TV page etc., and are accessed by pressing one of the colour coded keys (keys 9, 22, 24 and 25) on your handset.

To enter a favourite page first access the TEXT mode by pressing the TEXT key (3) on the handset. Now enter the favourite page mode by pressing the MENU button (key 20) on your handset (the MENU button allows the user to toggle between FASTEXT and FAVOURITE PAGE modes).

Enter the colour coded key you wish to use as the first favourite page (keys 9, 22, 24 and 25).

Now enter the page number you wish to assign to the desired colour coded key using the 0-9 buttons (key 3) on your handset. Once you have completed this step you must now store your selection in the TV's memory. Simply press and hold the selected colour coded key until the entire bottom fastext bar turns white. This is now stored.

If desired, another three favourite pages may be entered by following the above method, utilising the existing colour coded keys.

To view a Favourite Page simply press the MENU key whilst in FASTEXT and press the desired stored page using the Colour Coded keys on the handset.

VCR Operation

Your handset incorporates controls for operation of HITACHI Video Cassette Recorders. These controls are STANDBY, PLAY, STOP, FAST FORWARD and REVERSE and are located on the bottom of the handset.

To switch your VCR on or off simply press the VCR StandBy button (key 12)

To halt a cassette tape press the STOP button (key 13).

To rewind a cassette tape press REW button (key 14).

To begin playback of a cassette tape press the PLAY button (key 15).





To fast advance a cassette tape press F/FWD button (key 16).



Trouble Shooting Guide

The guide below is intended to help the user to identify common problems which may be encountered during the setup of this TV. If a problem still exists after referring to this guide, please consult your dealer immediately. Under no circumstances remove the rear cover of this TV. There are no user serviceable parts inside and you will be exposed to high voltages, which could cause a severe or fatal electric shock.

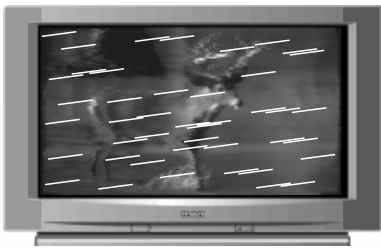
- Q. My TV fails to switch on.** **A. Check that plug is connected to socket and switched on. Check fuse and make sure TV is not in Stand-by mode (see below).**
- Q. My remote control handset does not work.** **A. Make sure there are no obstructions between the handset and the TV infra red lenses. The batteries may be exhausted - replace the whole set.**
- Q. The handset won't control my VCR.** **A. The handset is only programmed to control Hitachi VCR's.**

Problem Identification	Possible Reason	Remedy
 Snowy Picture - Poor Sound	<p><i>Aerial has moved out of position</i></p> <p><i>Corroded or poor aerial connections.</i></p> <p><i>Connection of RF lead to TV poor.</i></p> <p><i>Adverse weather conditions.</i></p> <p><i>Transmitter problems.</i></p>	<p><i>Re-align aerial.</i></p> <p><i>Make new connections or renew lead.</i></p> <p><i>Make new connection and/or change RF plug.</i></p> <p><i>None.</i></p> <p><i>Check with local Operator.</i></p>
 Multiple Images - Sound OK	<p><i>Aerial has moved out of position.</i></p> <p><i>TV not tuned correctly.</i></p> <p><i>Adverse weather conditions.</i></p> <p><i>Transmitter problems.</i></p>	<p><i>Re-align aerial.</i></p> <p><i>Re-tune or Fine tune TV.</i></p> <p><i>None.</i></p> <p><i>Check with local Operator.</i></p>
 Intermittent Interference	<p><i>Magnetic interference from electrical or mechanical motors, fluorescent lights, portable radios etc..</i></p>	<p><i>Check devices for shielding and renew if necessary or move further from TV.</i></p>
 No Picture or Sound	<p><i>TV may be in AV mode.</i></p> <p><i>TV in Stand-by.</i></p> <p><i>Picture/Sound controls set to minimum.</i></p>	<p><i>Press TV (key 1) button or 0-9 buttons to return to TV mode.</i></p> <p><i>Press 0-9 buttons.</i></p> <p><i>Check Picture/Sound controls (see Page 15/16).</i></p>

Guarantee

Your Guarantee

of Excellence

Thank you for purchasing this Hitachi television.

In the unlikely event that this product should develop a fault, we undertake to replace or repair any part of the product which fails due to a manufacturing defect within 12 months of the date of purchase provided that:

- i) The product has been installed and used only in accordance with the instructions supplied with the product.*
- ii) The product has not been repaired, maintained, or modified by any person other than an Hitachi authorised engineer.*
- iii) The product serial number has not been removed or altered.*

This guarantee does not apply to product acquired secondhand or for commercial or communal use.

This guarantee does not cover the replacement of exhausted batteries, the adjustment of user controls, or aerial alignment.

Any parts replaced under this guarantee shall become the property of Hitachi Home Electronics (Europe) Ltd.

Please note that evidence of the date of purchase will be required before any service under this guarantee is carried out.

THIS GUARANTEE DOES NOT AFFECT YOUR STATUTORY RIGHTS.

IN ALL CASES OF DIFFICULTY PLEASE CONSULT YOUR HITACHI DEALER.

Technical Specifications

TV Standard.....	625 line single standard
Channel Coverage.....	UHF channels
Aerial Impedance.....	75 Ω unbalanced
Picture Tube.....	56cm
Mains Voltage.....	220 - 240V AC 50 Hz
Internal Speakers.....	6 x 12 cm type x 2
Power Consumption.....	56cm models 97W approx.
(All Models Stand-by <6W)	
Weight.....	56cm models 22.7kg approx.
Dimensions (W x H x D).....	56cm models 663 x 444 x 474mm
Remote Control Batteries.....	2 x HITACHI SUM-3 /equivalent AA

Specifications are subject to change without notice. Weight and dimensions shown are approximate.

SCART SOCKET AV1

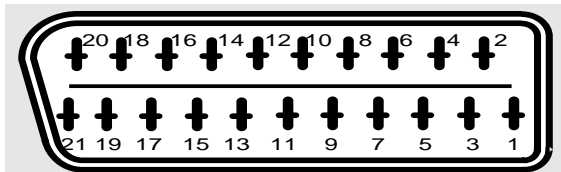

PIN No.	FUNCTION
1	AUDIO OUT (RIGHT)
2	AUDIO INPUT (RIGHT)
3	AUDIO OUT (LEFT)
4	GROUND (AUDIO)
5	GROUND (BLUE)
6	AUDIO INPUT (LEFT)
7	BLUE INPUT
8	SWITCHING INPUT
9	GROUND (GREEN)
10	NOT USED
11	GREEN INPUT
12	NOT USED
13	GROUND (RED)
14	GROUND (BLANKING)
15	RED INPUT
16	STATUS (BLANKING) INPUT
17	GROUND (VIDEO)
18	GROUND (VIDEO)
19	COMPOSITE VIDEO OUTPUT
20	COMPOSITE VIDEO INPUT
21	GROUND

SCART SOCKET AV2

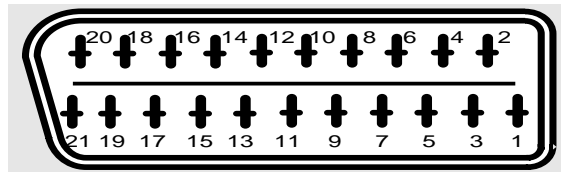

PIN No.	FUNCTION
1	AUDIO OUT (RIGHT)
2	AUDIO INPUT (RIGHT)
3	AUDIO OUT (LEFT)
4	GROUND (AUDIO)
5	NOT USED
6	AUDIO INPUT (LEFT)
7	NOT USED
8	SWITCHING INPUT
9	NOT USED
10	NOT USED
11	NOT USED
12	NOT USED
13	CHROMINANCE GROUND
14	NOT USED
15	CHROMINANCE INPUT S-VHS
16	NOT USED
17	GROUND (VIDEO)
18	GROUND (VIDEO)
19	COMPOSITE VIDEO OUTPUT
20	COMPOSITE VIDEO OR
21	COMPOSITE LUMINANCE S-VHS
	GROUND

S-VHS SOCKET

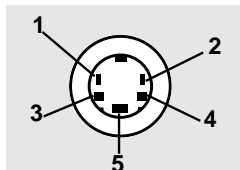

PIN	FUNCTION
1	Chrominance input
2	Luminance input
3	Chrominance ground
4	Luminance ground
5	Frame ground

HITACHI ENVIRONMENTAL NOTICE

The Environment and You

HITACHI are signatories to the commitment made by the Consumer Electronics Industry on Reducing Energy Consumption by Televisions and Video Recorders in Standby.

HOW YOU CAN CONTRIBUTE TO THE ENVIRONMENT BY HELPING TO REDUCE ENERGY CONSUMPTION AND WASTE!

Even though your TV has a low standby power consumption, you can reduce waste to zero if you switch off the set at the mains when it is not intended to be used for long periods i.e. for an Hour or so. TV sets should certainly be switched off overnight or when you are away from home. Other factors should also be considered when operating your TV. Reducing volume settings to sensible levels can reduce power consumption as well as reducing noise pollution, and reducing the contrast can also provide a more pleasing picture in lower ambient lighting conditions as well as reducing power consumption.

Hitachi Home Electronics (Europe) Ltd. Manufacturing Site in Wales is a BSI Registered Company, and has been assessed to ISO 9001 Quality Management Standard, certificate number FM 32366 and the Environmental Quality Management Standard ISO 14001, certificate number EMS 36168, under which your Television has been manufactured.

The paper used for this Operating Guide has been produced from sustainable forests, part of Hitachi's on going commitment to the global environment.

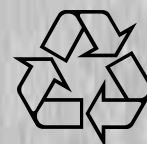

HITACHI

Hitachi, Ltd. Tokyo, Japan
International Sales Division
THE HITACHI ATAGO BUILDING,
No. 15-12 Nishi Shinbashi, 2-Chome,
Minato-Ku, Tokyo 105-8430, Japan.
Tel: 03 35022111

HITACHI EUROPE LTD,

Whitebrook Park
Lower Cookham Road
Maidenhead
Berkshire
SL6 8YA

UNITED KINGDOM

Tel: 01628 643000
Fax: 01628 643400
Email: consumer-service@hitachi-eu.com

HITACHI EUROPE S.A.

364 Kifissias Ave. & 1, Delfon Str.
152 33 Chalandri
Athens

GREECE

Tel: 1-6837200
Fax: 1-6835964
Email: service.hellas@hitachi-eu.com

HITACHI EUROPE GmbH

Munich Office
Dornacher Strasse 3
D-85622 Feldkirchen bei München

GERMANY

Tel: +49-89-991 80-0
Fax: +49-89-991 80-224
Hotline: +49-180-551 25 51 (12ct/min)
Email: HSE-DUS.service@hitachi-eu.com

HITACHI EUROPE S.A.

Gran Via Carlos III, 101-1
08028 Barcelona

SPAIN

Tel: 93 409 2550
Fax: 93 491 3513
Email: atencion.cliente@hitachi-eu.com

HITACHI EUROPE srl

Via Tommaso Gulli N.39, 20147
Milano, Italia

ITALY

Tel: +39 02 487861
Tel: +39 02 38073415 Servizio Clienti
Fax: +39 02 48786381/2
Email: customerservice.italy@hitachi-eu.com

HITACHI Europe AB

Box 77 S-164 94 Kista

SWEDEN

Tel: +46 (0) 8 562 711 00
Fax: +46 (0) 8 562 711 13
Email: csgswe@hitachi-eu.com

HITACHI EUROPE S.A.S

Lyon Office
B.P. 45, 69671 BRON CEDEX

FRANCE

Tel: 04 72 14 29 70
Fax: 04 72 14 29 99
Email: france.consommateur@hitachi-eu.com

HITACHI EUROPE LTD (Norway) AB

STRANDVEIEN 18

1366 Lysaker

NORWAY

Tel: 67 5190 30
Fax: 67 5190 32
Email: csgnor@hitachi-eu.com

HITACH EUROPE AB

Egebækgård
Egebækvej 98
DK-2850 Nærum

DENMARK

Tel: +45 43 43 6050
Fax: +45 43 60 51
Email: csgnor@hitachi-eu.com

HITACHI EUROPE AB

Neopoli / Niemenkatu 73
FIN-15140 Lahti

FINLAND

Tel : +358 3 8858 271
Fax: +358 3 8858 272
Email: csgnor@hitachi-eu.com

Hitachi Europe Ltd

Bergensesteenweg 421
1600 Sint-Pieters-Leeuw

BELGIUM

Tel: +32 2 363 99 01
Fax: +32 2 363 99 00
Email: sofie.van.bom@hitachi-eu.com

HITACHI EUROPE LTD

Na Sychrove 975/8
101 27 Praha 10 – Bohdalec

CZECH REPUBLIC

Tel: +420 267 212 383
Fax: +420 267 212 385
Email: csgnor@hitachi-eu.com

www.hitachidigitalmedia.com